

XII  
1.1

**ZIMM**<sup>®</sup> Austria  
Screw Jack Systems

---

**Screw Jack Systems**

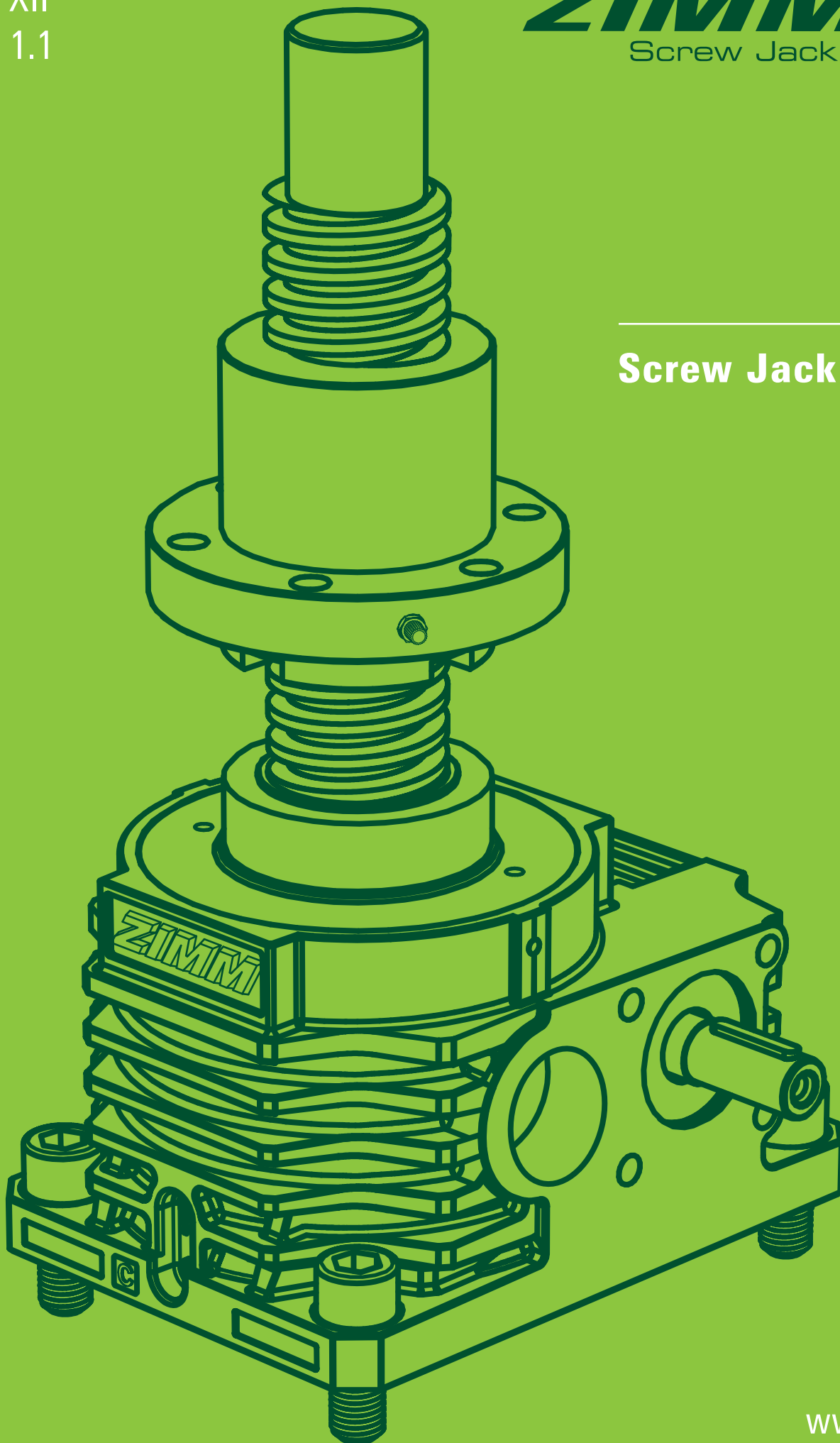

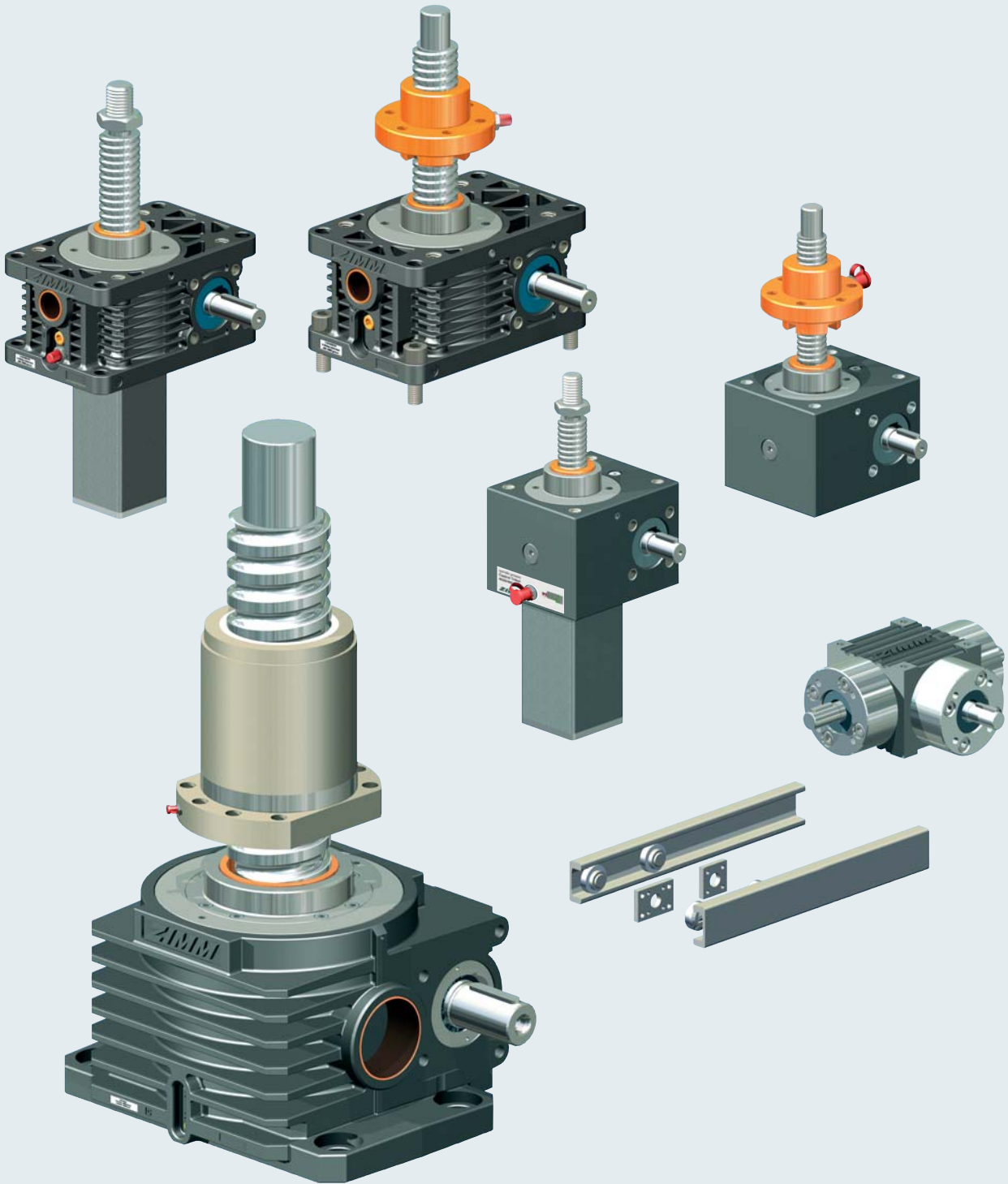

The ZIMM Transmission Parts catalogue is available for download from [www.zimm.at](http://www.zimm.at) or on request (*in German only available*)



1	<p>Screw jack systems – Overview          Modular options – Overview          Product features</p>		<p>Product overview</p>
2	<p>Z-Tr trapezoidal screw jacks          Z-KGT ball screw jacks          Z-SIFA screw jacks with safety nuts</p>		<p>Z series          Screw jacks          5 kN to 1,000 kN</p>
3	<p>GSZ-Tr trapezoidal screw jacks          GSZ-KGT ball screw jacks          GSZ-SIFA screw jacks with safety nuts</p>		<p>GSZ series          Screw jacks          2.5 kN to 100 kN</p>
4	<p>Accessories for screw jack systems</p>		<p>Accessories</p>
5	<p>Bevel gearboxes</p>		<p>Bevel gearboxes</p>
6	<p>Linear guides</p>		<p>Linear guides</p>
7	<p>Checklists for enquiries</p>		<p>Checklists</p>
8	<p>Design advice          Selection, calculations          Operation/Maintenance          Special applications and conditions</p>		<p>Technical appendix</p>
9	<p>Example applications</p>		<p>Example applications</p>
10	<p>Other products: Transmission Parts          ZIMM – the company          Copyright, Imprint, How to reach us          General Terms and Conditions, Distributors</p>		<p>About ZIMM,          Contacts</p>

Complete solutions from a single source

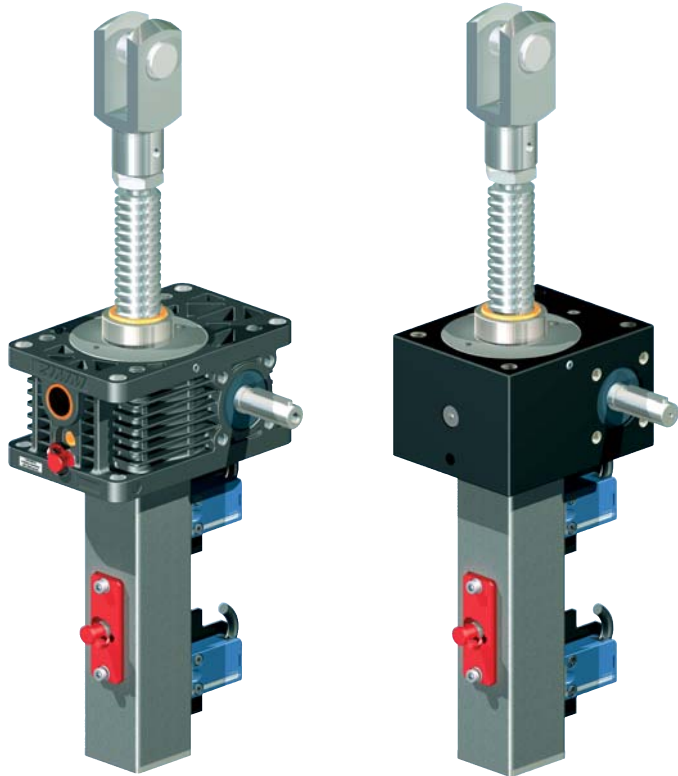

**CAD files:**  
To assist your design process,  
CAD files for our components  
are available at [www.zimm.eu](http://www.zimm.eu)

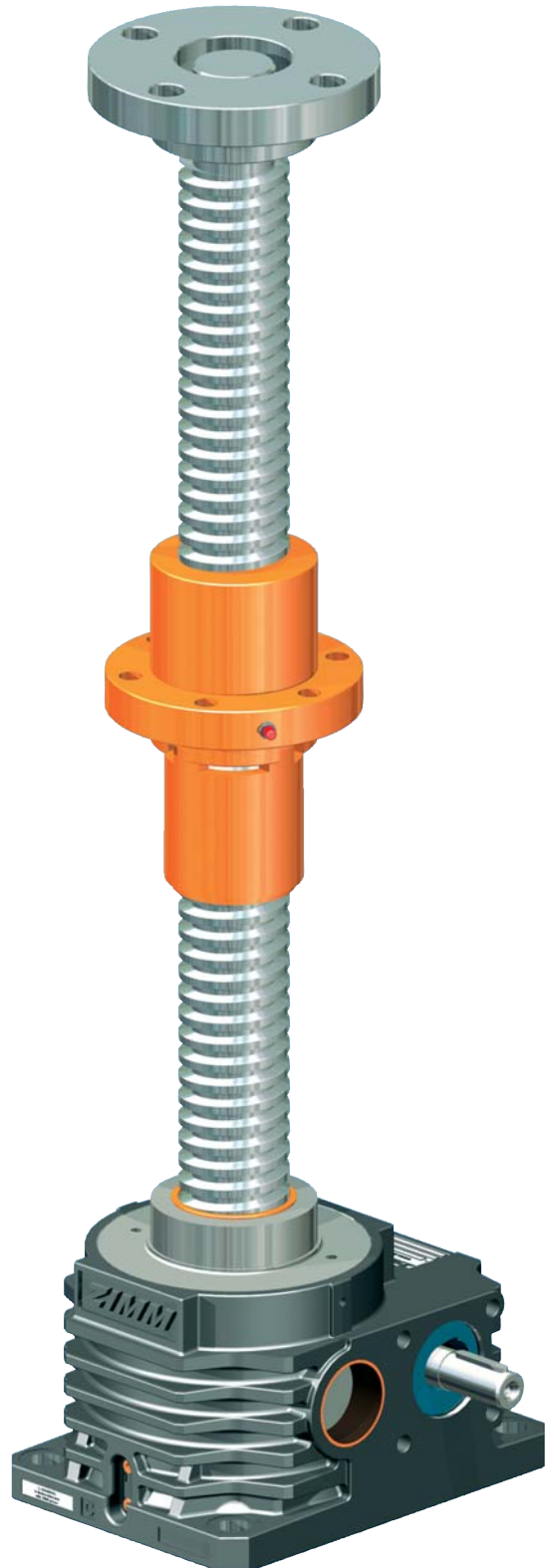

## Complete solutions from a single source

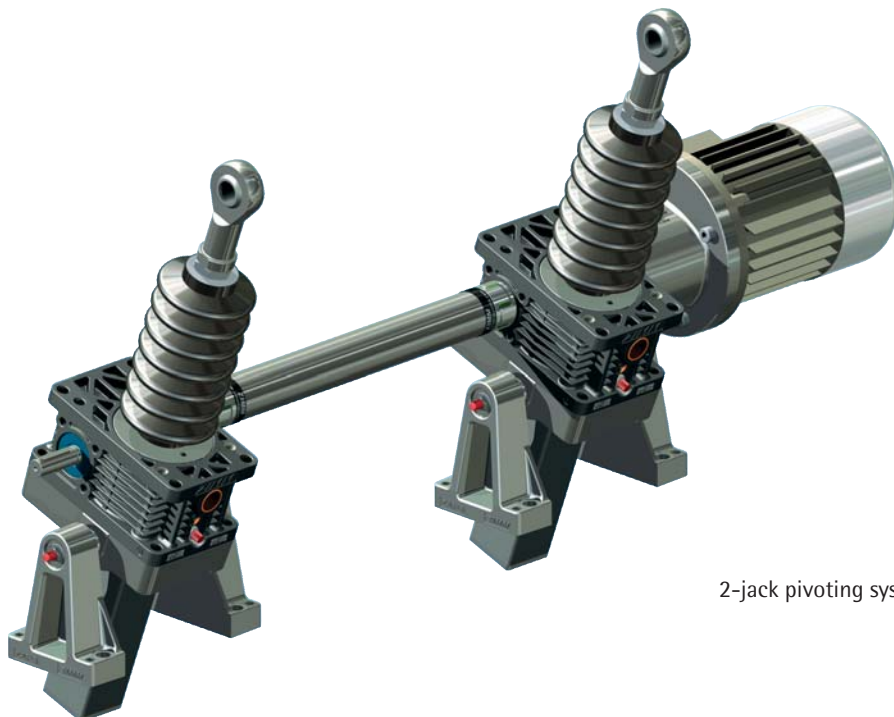
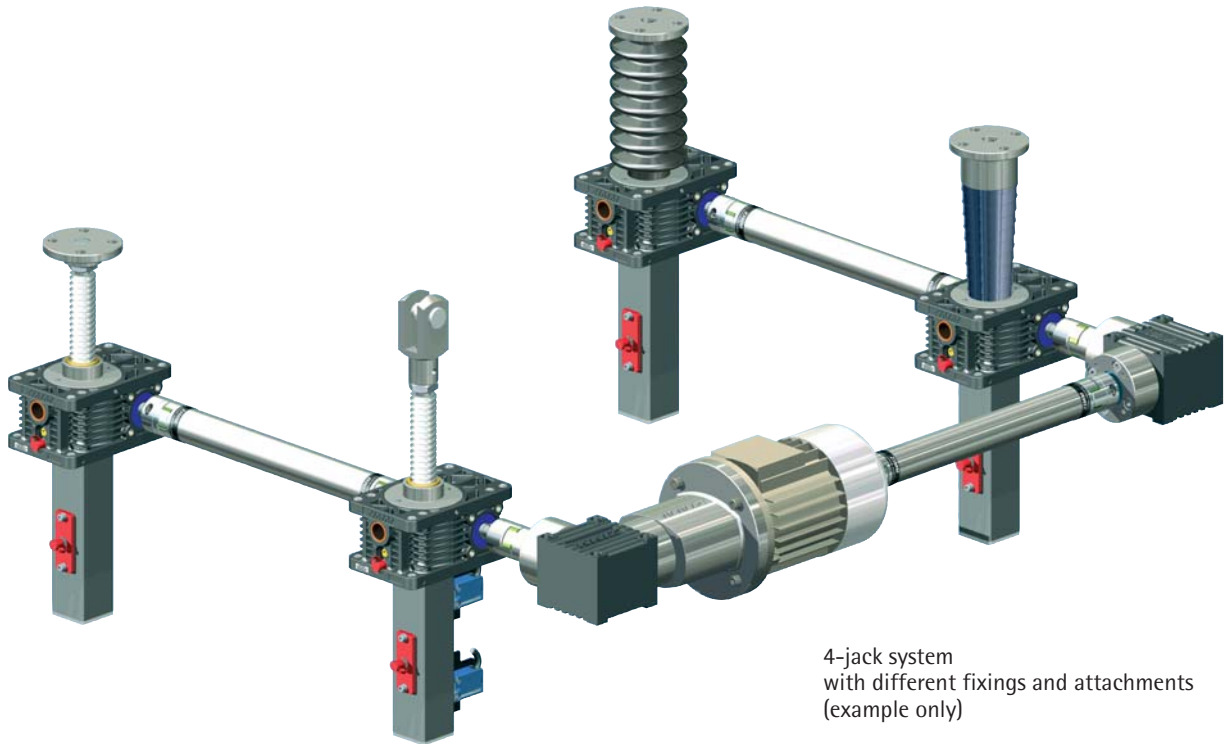

We have patents registered or pending for a range of functions and components.



# Overview

## Sizes/types

### Z series

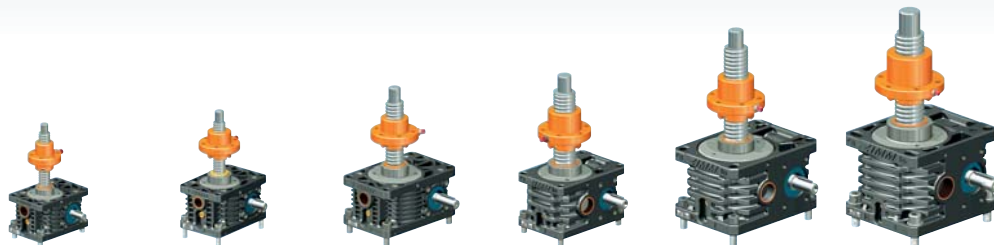
(Section 2)





Load	5 kN		10 kN		25 kN		35 kN		50 kN		100 kN	
	S	R	S	R	S	R	S	R	S	R	S	R
S translating screw R rotating screw	Version	Version	Version	Version	Version	Version	Version	Version	Version	Version	Version	Version
Drive ratios	i= 4:1 i= 16:1		i= 4:1 i= 16:1		i= 6:1 i= 24:1		i= 7:1 i= 28:1		i= 7:1 i= 28:1		i= 9:1 i= 36:1	
Housing material	Aluminium		Aluminium		Aluminium		GGG-50		GGG-50		GGG-50	
Z-Tr  with trapezoidal screw	18x4	18x4	20x4	20x4	30x6	30x6	40x7	40x7	40x7 50x8	40x7	55x9	55x9
Z-KGT  with ball screw	16x5 16x10	16x5 16x10	25x5 25x10 25x25 25x50	25x5 25x10 25x25 25x50	32x5 32x10 32x20 32x40	32x5 32x10 32x20 32x40			40x5 40x10 40x20 40x40	40x5 40x10 40x20 40x40	50x10 50x20 50x40	50x10 50x20 50x40 50x50
Z-SIFA  with safety nut		18x4	20x4	20x4	30x6	30x6	40x7	40x7	40x7	40x7	55x9	55x9

### GSZ series

(Section 3)



Load	2.5 kN		5 kN		10 kN		25 kN		50 kN		100 kN			
	S	R	S	R	S	R	S	R	S	R	S	R		
S translating screw R rotating screw	Version	Version	Version	Version	Version	Version	Version	Version	Version	Version	Version	Version		
Drive ratios	i= 4:1 i= 16:1		i= 4:1 i= 16:1		i= 4:1 i= 16:1		i= 6:1 i= 24:1		i= 7:1 i= 28:1		i= 9:1 i= 36:1			
Housing material	Aluminium		Aluminium		Aluminium		Aluminium		GGG-50		GGG-50			
GSZ-Tr  with trapezoidal screw	16x4	16x4	18x4	18x4	20x4	20x4	30x6	30x6			40x7	40x7	55x9	55x9
GSZ-KGT  with ball screw		16x5 16x10	16x5 16x10	16x5 16x10	25x5 25x10 25x25 25x50	25x5 25x10 25x25 25x50	32x5 32x10 32x20 32x40	32x5 32x10 32x20 32x40			40x5 40x10 40x20 40x40	40x5 40x10 40x20 40x40	50x10 50x20 50x40 50x50	
GSZ-SIFA  with safety nut		16x4		18x4	20x4	20x4	30x6	30x6			40x7	40x7	55x9	55x9

Screw versions: increased / double-pitch / left-handed / stainless steel

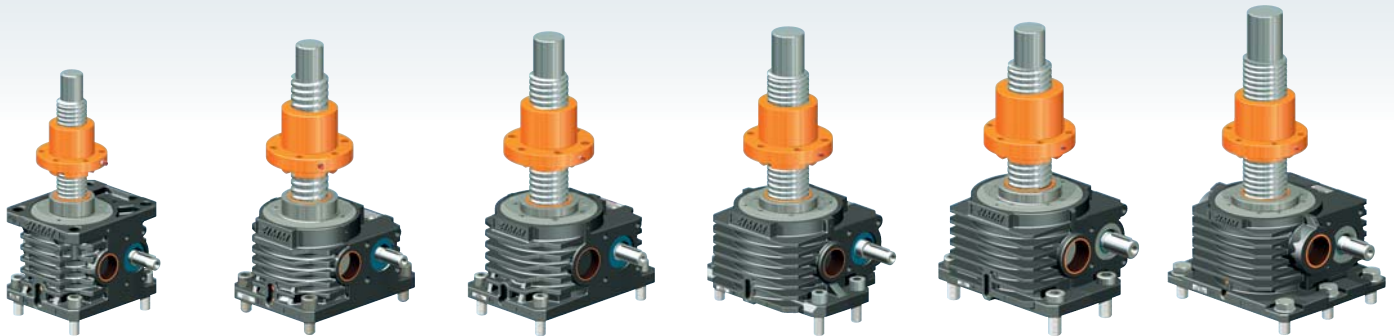

150 kN		250 kN		350 kN		500 kN		750 kN		1000 kN	
S	R	S	R	S	R	S	R	S	R	S	R
Version	Version	Version	Version	Version	Version	Version	Version	Version	Version	Version	Version
i= 9:1		i= 10.66:1		i= 10.66:1		i= 10.66:1		i= 13.33:1		i= 13.33:1	
i= 36:1		i= 32:1		i= 32:1		i= 32:1		i= 40:1		i= 40:1	
GGG-50		GGG-50		GGG-50		GGG-50		GGG-50		GGG-50	
60x9	60x9	80x16	80x16	100x16	100x16	120x16	120x16	140x20	140x20	160x20	160x20
63x10	63x10	80x10	80x10	100x20	100x20	125x25	125x25	140x25	140x25	160x25	160x25
63x20	63x20	80x20	80x20	100x40	100x40	125x40	125x40	140x40	140x40	160x40	160x40
63x40	63x40	80x40	80x40	100x60	100x60	125x60	125x60	140x60	140x60	160x60	160x60
63x60	63x60	80x60	80x60	100x80	100x80	125x80	125x80	140x80	140x80	160x80	160x80
60x9	60x9	80x16	80x16	100x16	100x16	120x16	120x16	140x20	140x20	160x20	160x20

**When should I use a Z series screw jack?**

Z series screw jacks are the preferred range with the largest number of types. The Z series feature through holes for top mounting and integral pivot bearings, features not available on the GSZ series.

**When should I use a GSZ series screw jack?**

GSZ series screw jacks are designed for applications where smooth surfaces are required. These screw jacks are easier to clean and therefore ideal for applications in the food processing industry.

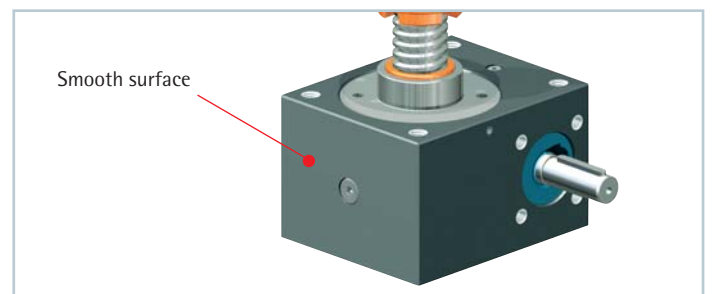
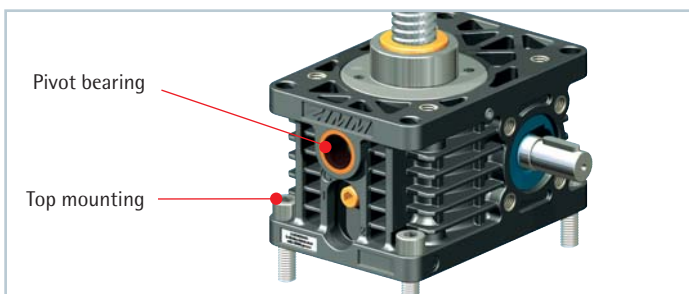

**The development of ZIMM screw jack system**

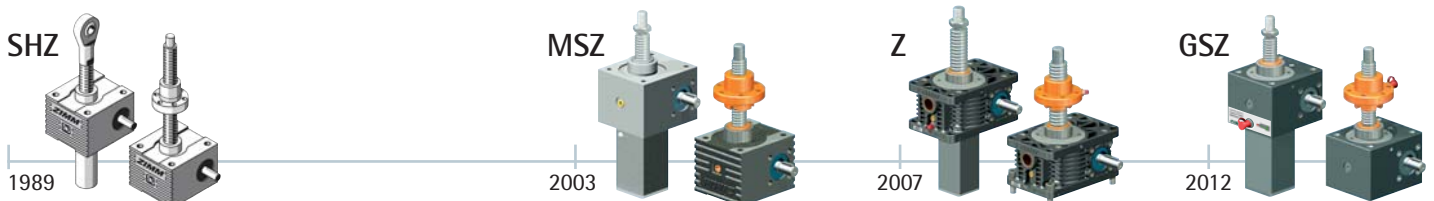

# S version (Translating screw)

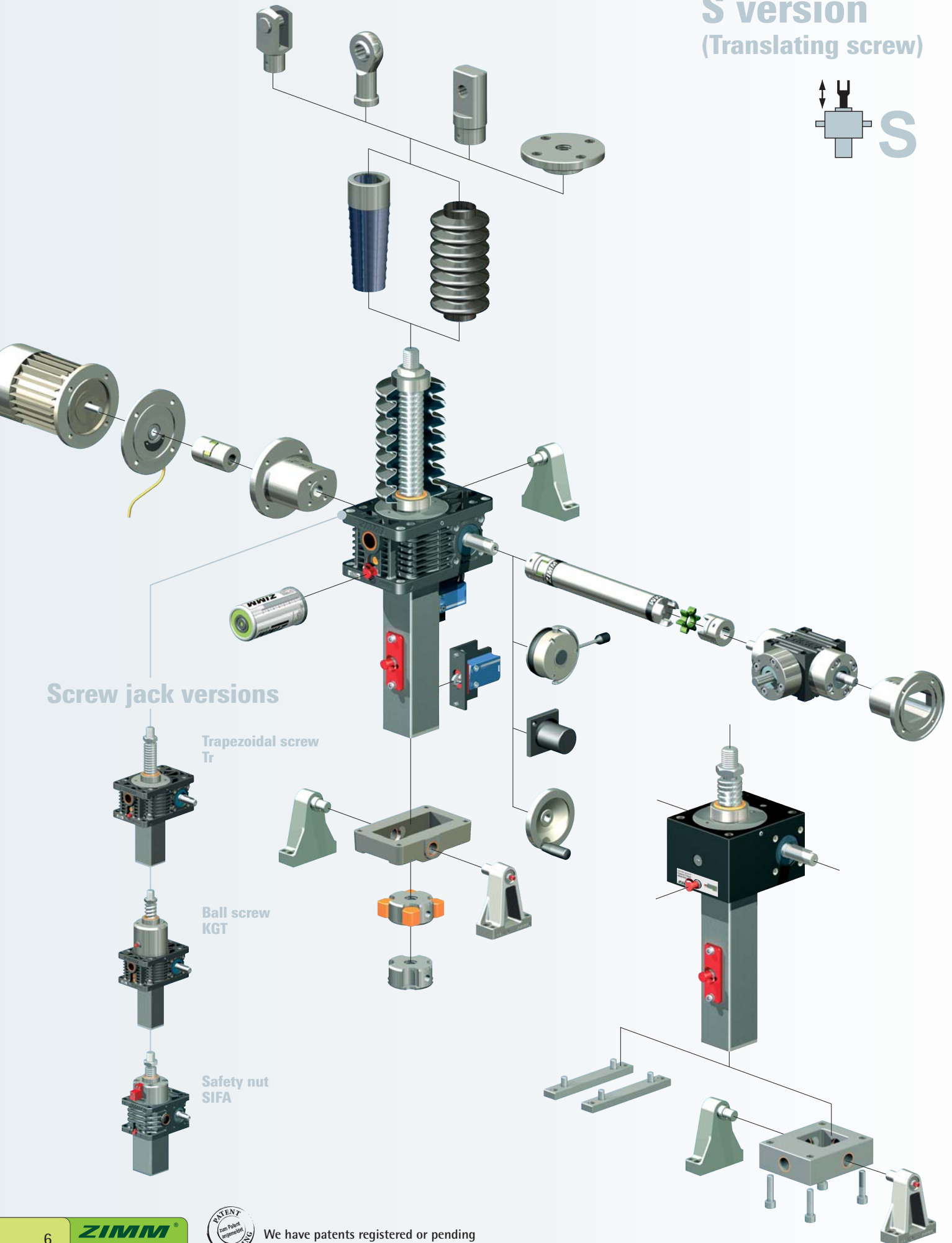
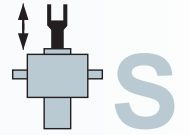

## Screw jack versions

Trapezoidal screw  
Tr

Ball screw  
KGT

Safety nut  
SIFA





# R version (Rotating screw)

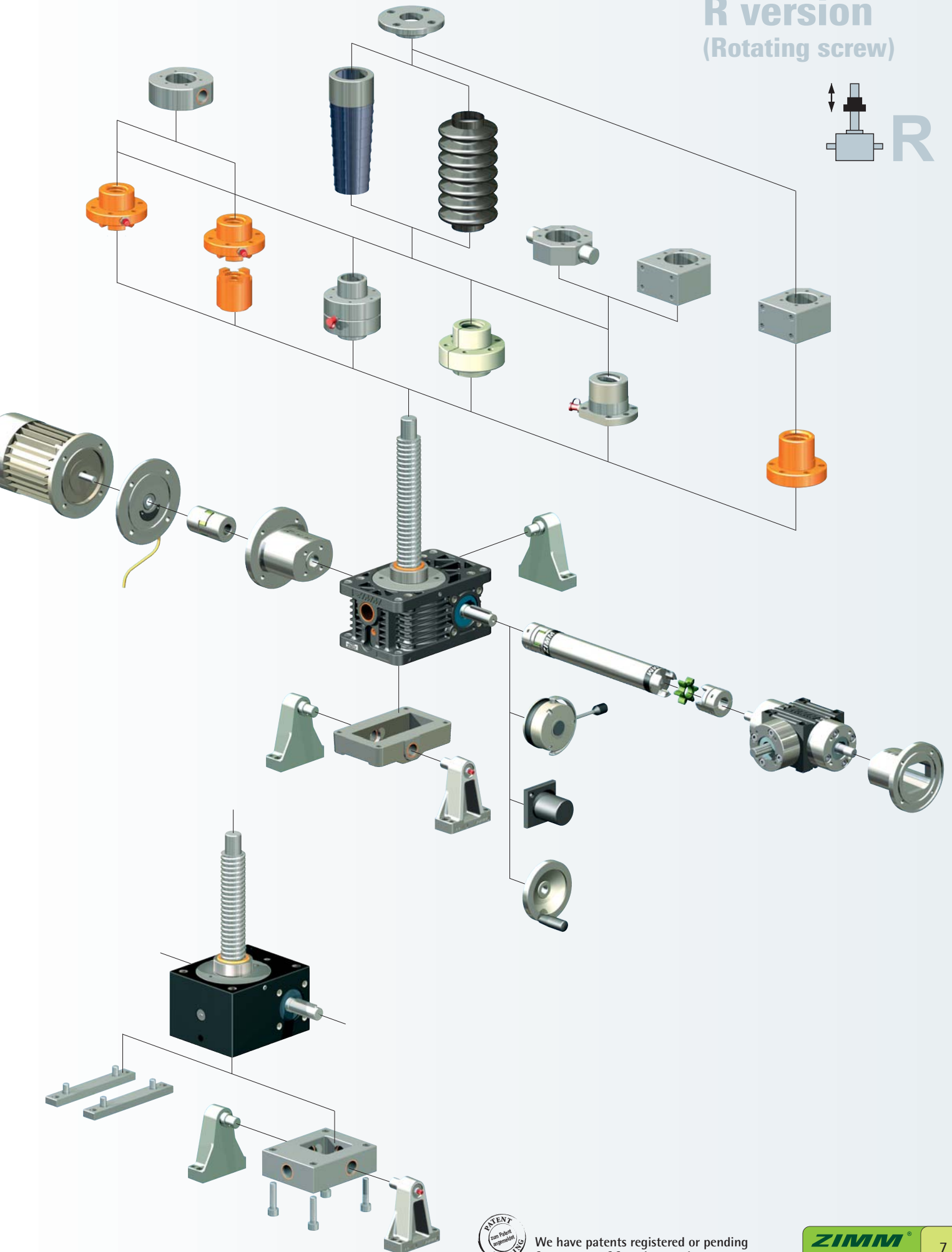
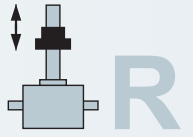

We have patents registered or pending for a range of functions and components.

Z series - features

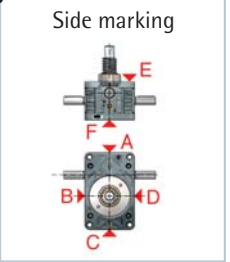
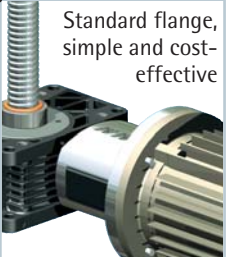
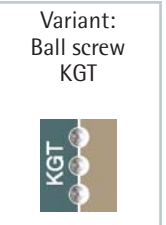
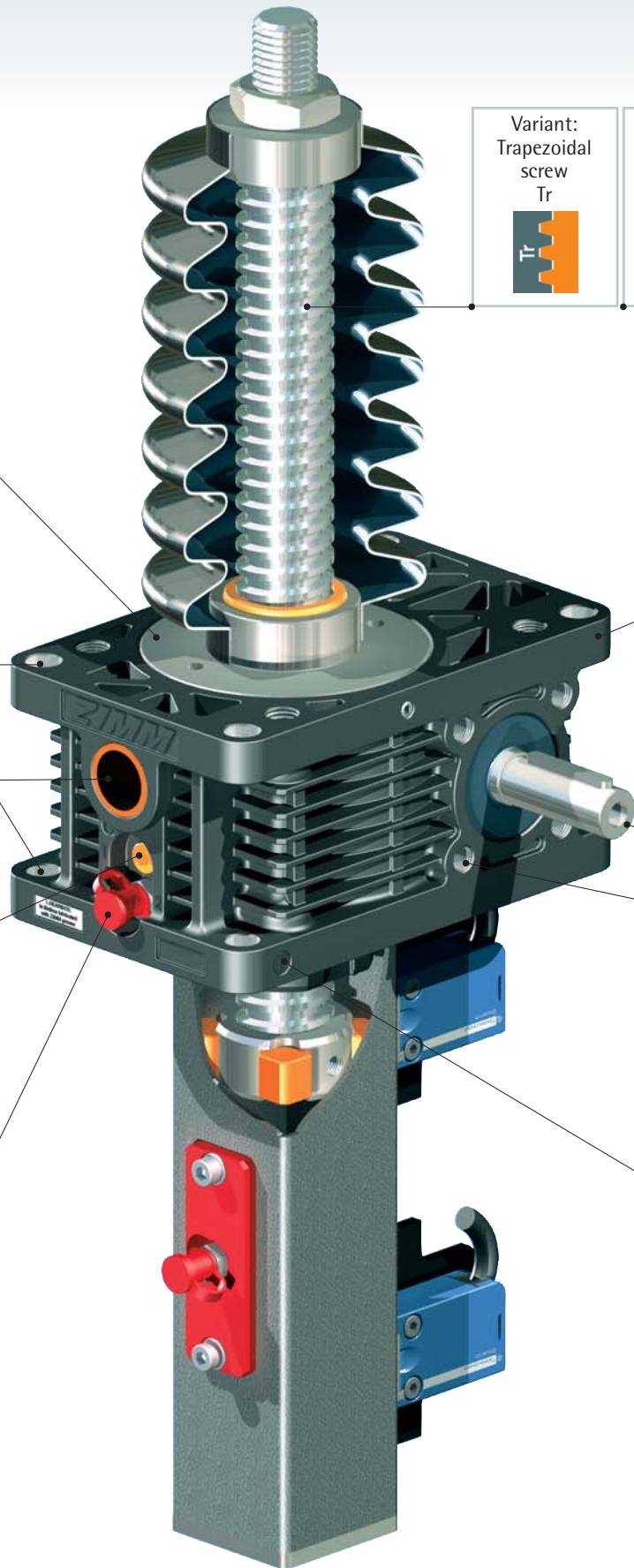
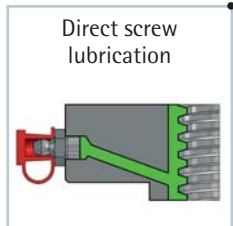
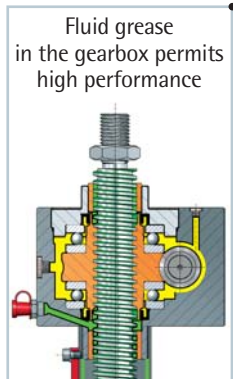
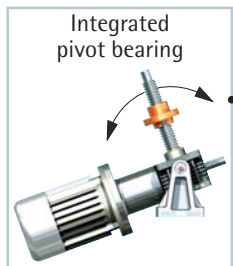
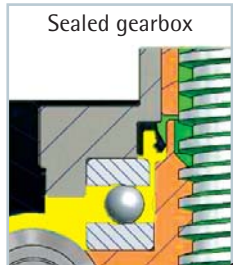

GSZ series - features

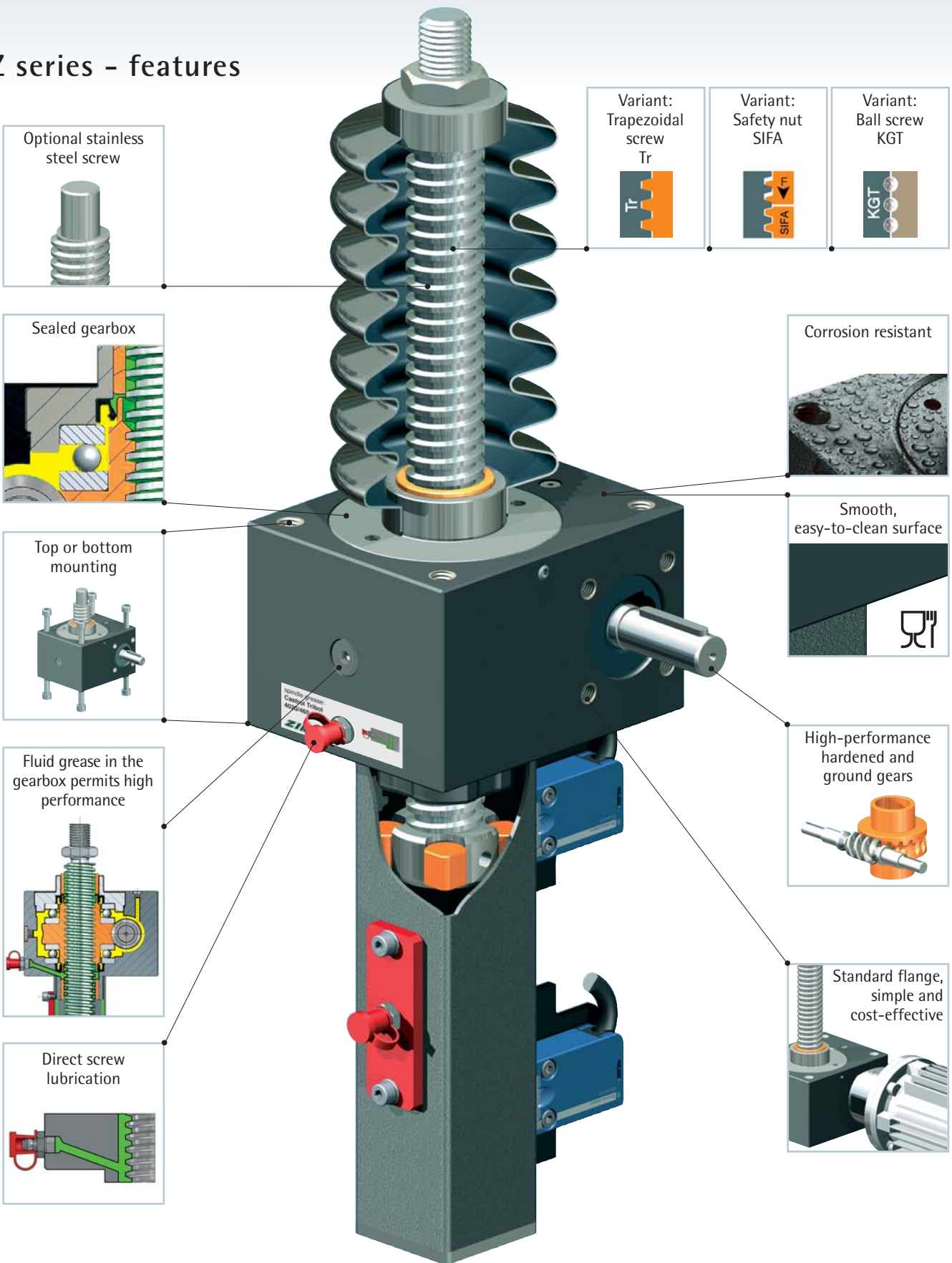

Optional stainless steel screw

Sealed gearbox

Top or bottom mounting

Fluid grease in the gearbox permits high performance

Direct screw lubrication

Variant: Trapezoidal screw Tr

Variant: Safety nut SIFA

Variant: Ball screw KGT

Corrosion resistant

Smooth, easy-to-clean surface

High-performance hardened and ground gears

Standard flange, simple and cost-effective



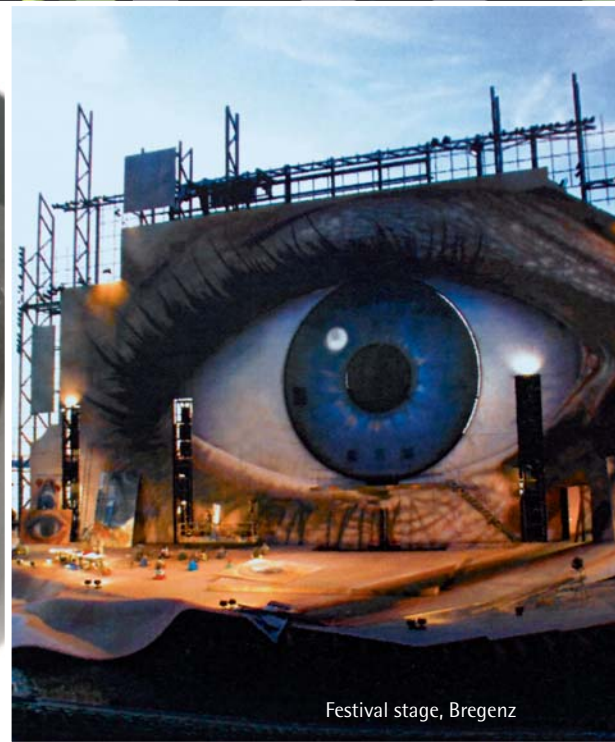

# product and environment

Photo: © studio 22



1



Lake Constance, Hard

in harmony.

# Z series

Z series screw jacks are the preferred range with the largest number of types. The Z series features through holes for top mounting and integral pivot bearings, features not available on the GSZ series.

Pivot bearing

Top mounting

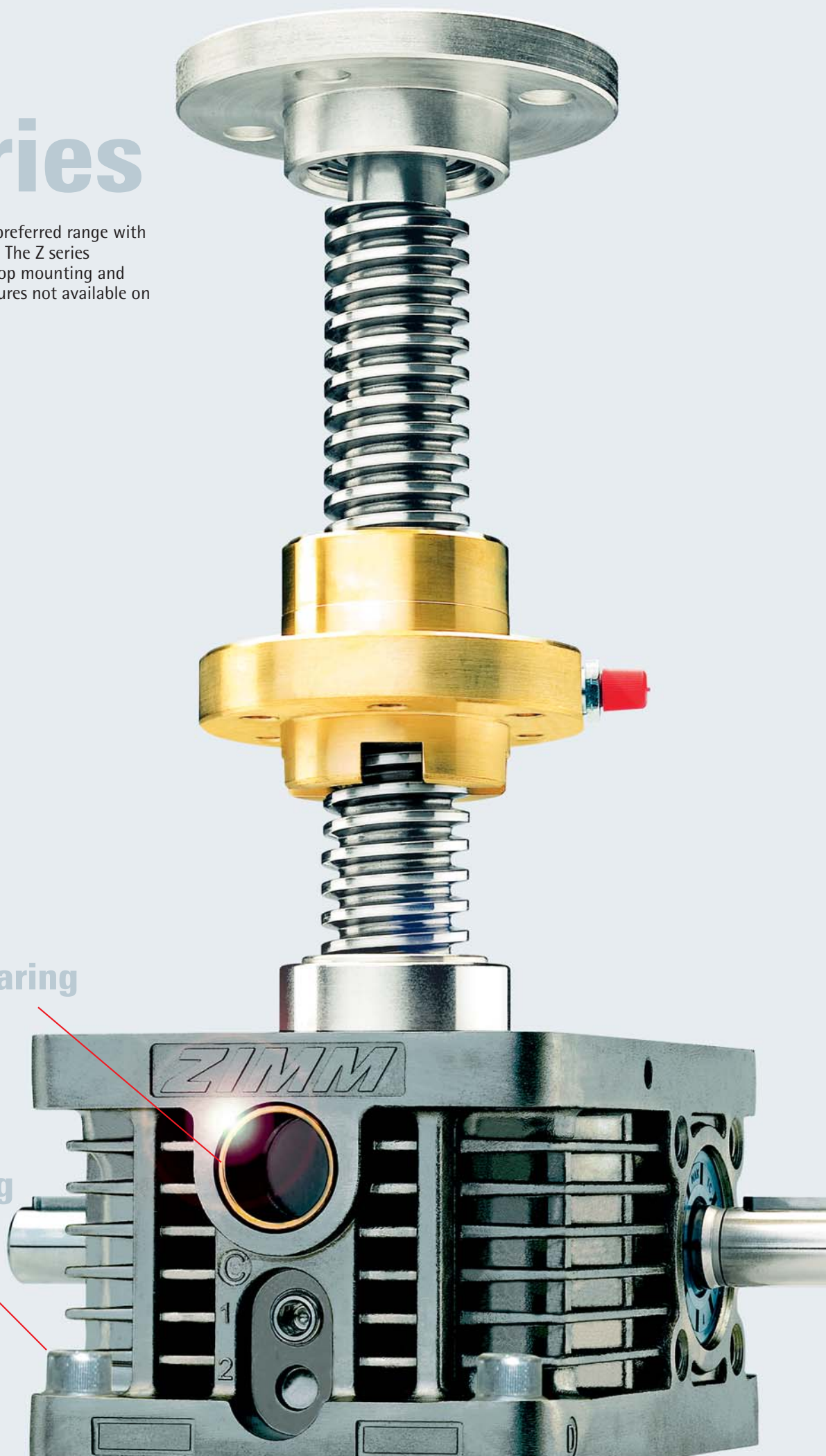

## Types and sizes

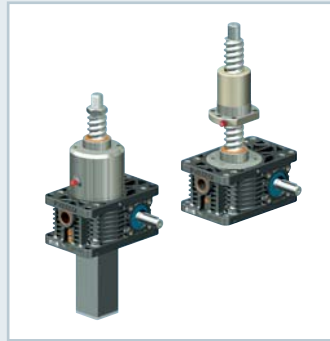
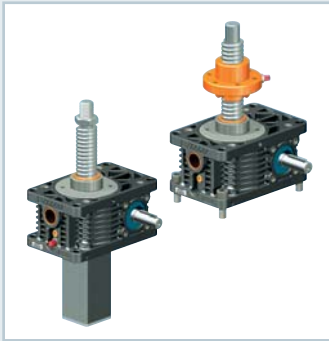

Z series jacks Tr  
Trapezoidal screw  
5 kN to 1,000 kN

Pages 14 - 39



Z series jacks KGT  
Ball screw  
5 kN to 1,000 kN

Pages 40 - 49



Z series jacks SIFA  
Safety nut  
5 kN to 1,000 kN

Pages 50 - 55



We have patents registered or pending for a range of functions and components.



UNIQUE:  
Screw lubrication  
during operation

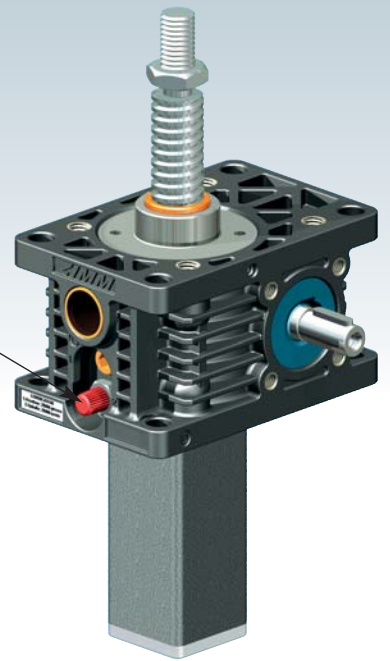

Z-5-S translating screw 5 kN

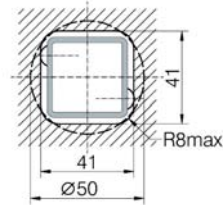
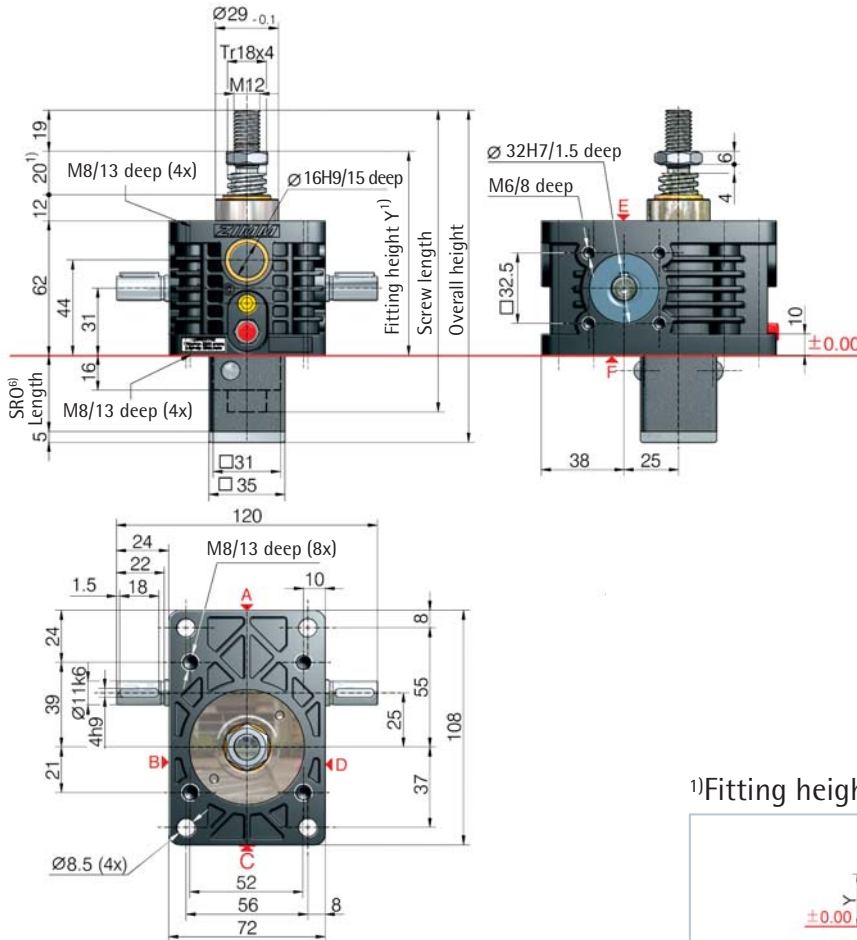

1)Fitting height for 0-stroke, with Tr 18x4 screw

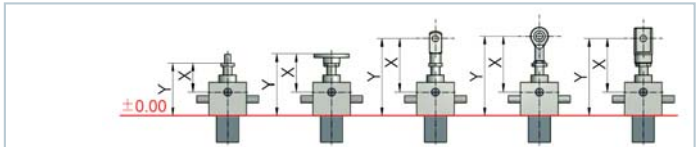

6)Protective tube length SRO with Tr 18x4 screw

Without escape/ rotation protection	Escape/ rotation protection	Rotation protection, with limit switch set ES	Rotation protection with ES and KAR*
46+stroke	61+stroke	119+stroke	140+stroke

\*Hinged bearing plate KAR, fitted on face F (below).

Bellocs FB	X/Y	X/Y	X/Y	X/Y	X/Y
without bellocs FB	50/94	70/114	98/142	100/144	98/142
Z-5-FB-265	83/127	83/127	131/175	133/177	111/155
Z-5-FB-500	148/192	148/192	196/240	198/242	176/220
Z-5-FB-800	168/212	168/212	216/260	218/262	196/240

\*with bellows fixing ring Z-5-FBR

Standard ratios

Type	Version	Speed	Standard screw <sup>2)</sup>	i	Stroke per drive shaft rotation <sup>5)</sup>
Z-5-SN	Translating	Normal	Tr 18x4	4:1	1.00 mm
Z-5-SL	screw	Low		16:1	0.25 mm
Z-5-RN	Rotating	Normal	Tr 18x4	4:1	1.00 mm
Z-5-RL	screw	Low		16:1	0.25 mm

Screw jack mounting



Duty cycle thermal limit, for S+R

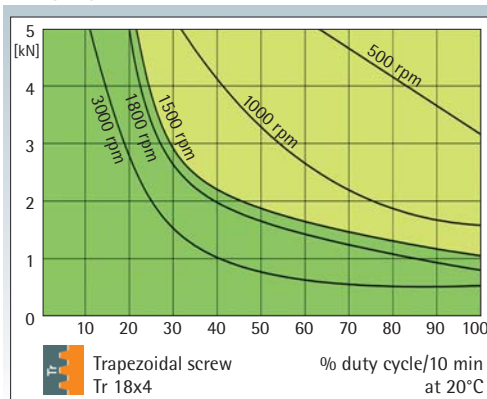

These curves are for guidance under standard industrial conditions (ambient temperature etc.) and correct maintenance (lubrication etc.). The max. input drive torques for optimum service life are at the right page - technical data (1500 rpm)

KGT: % duty cycle 2 times to 4 times higher



Trapezoidal screw

Tr



## Z-5-R rotating screw 5 kN

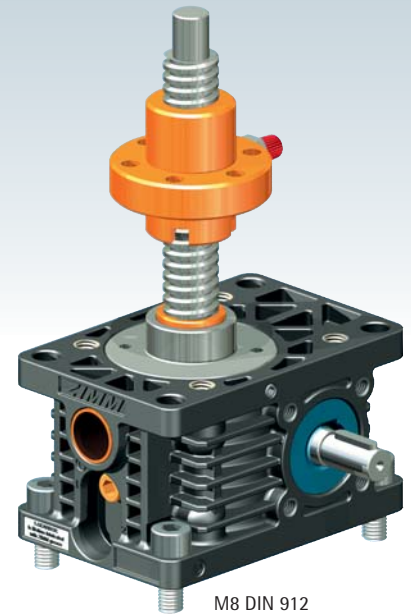
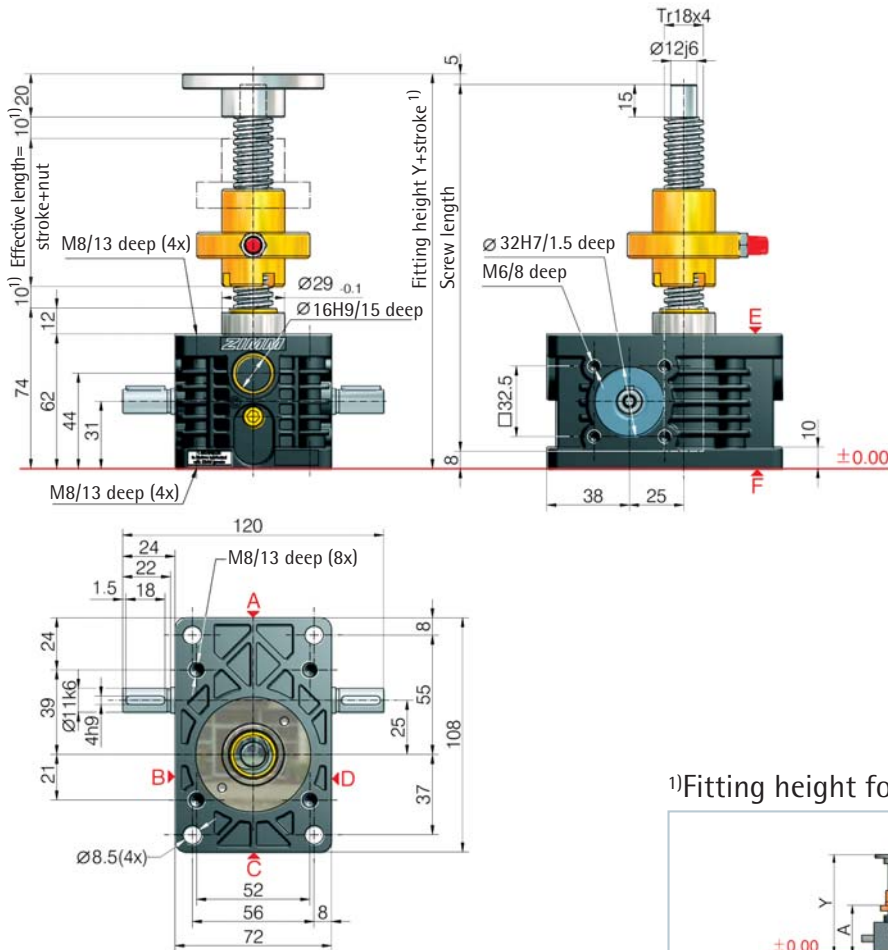

<sup>1)</sup>Fitting height for 0-stroke, with Tr 18x4 screw

All dimensions in mm	Flange nut FM	Duplex nut DM	Duplex nut DM with SIFA	Self-aligning nut PM	Greaseless nut FFDM
	Y/A	Y/A	Y/A	Y/A	Y/A
Bellows FB	149/96	159/109	184/134	192/141	167/117
without bellows FB	-	207/132	229/154	240/164	215/140
2x Z-5-FB-265	-	337/197	359/219	370/229	345/205
2x Z-5-FB-500	-	377/217	399/239	410/249	385/225

Detailed instructions for determining the length can be found in Section 8

# 5

kN

## Technical data series Z-5-S / Z-5-R

max. compressive/tensile force, static	- 5 kN (0.5 t)
max. compressive/tensile force, dynamic	- see duty cycle curves
Nominal speed	- 1500 rpm
max. drive shaft speed	- 3000 rpm (depending on the load and duty cycle)
Screw size standard	- Tr 18x4 <sup>2)</sup>
Gear ratio	- 4:1 (N) / 16:1 (L)
Housing material	- aluminium, corrosion-resistant
Worm shaft	- steel, case-hardened, ground
Weight of screw jack body	- 1.2 kg
Weight of screw/m	- 1.58 kg
Gearbox lubrication	- synthetic fluid grease
Screw lubrication	- grease lubrication
Gearbox operating temperature	- max. 60°C, higher on request
Moment of inertia	- N: 0.217 kg cm <sup>2</sup> / L: 0.117 kg cm <sup>2</sup>
Input torque (at 1500 rpm)	- max. 4.7 Nm (N) / max. 1.5 Nm (L)
Drive-through torque	- max. 39 Nm

Drive torque $M_G$ (Nm)	- $F$ (kN) $\times$ 0.62 <sup>3)5)</sup> + $M_L$ (N-normal) - $F$ (kN) $\times$ 0.21 <sup>3)5)</sup> + $M_L$ (L-low)
Breakaway torque	- Drive torque $M_G \times 1.5$
Idling torque <sup>4)</sup> $M_L$ (Nm)	- 0.10 (N-normal) / 0.08 (L-low speed)

Between gearbox and nut or nut and end of thread, provide for a safety distance of (minimum) 10 mm!

See Section 7 for the checklist.

## Important information

- 1) - extension if a bellows or spiral spring is fitted: see the table or Section 8
- 2) - Tr 18x4 is standard, also available: double-pitch, stainless steel, left-handed, increased screw Tr 20x4 (only for the R version)
- 3) - factor includes efficiency, ratio and 30% safety
- 4) - at 20°C, can be higher when new
- 5) - for a 4 mm screw pitch



Z-10-S translating screw 10 kN

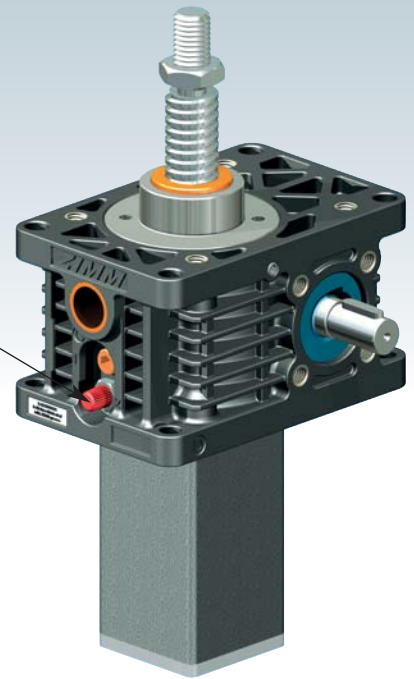

UNIQUE:  
Screw lubrication  
during operation

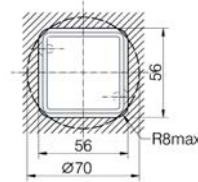
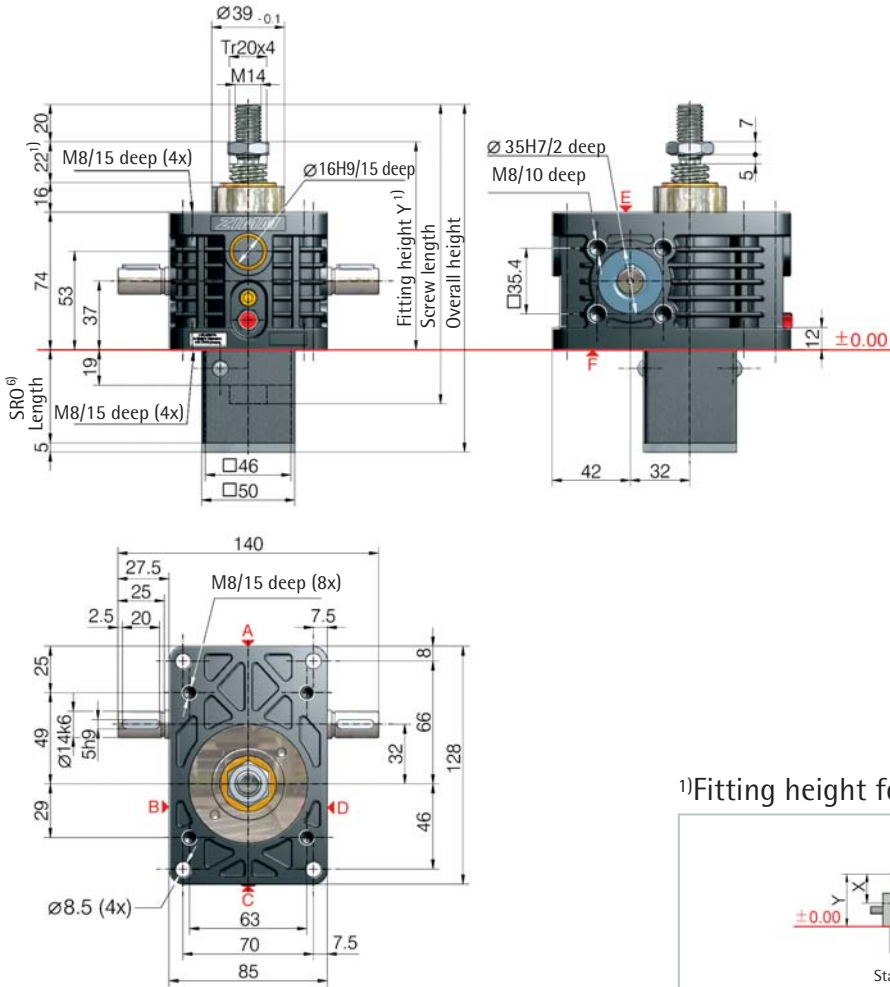

6) Protective tube length SRO with Tr 20x4 screw

Without escape/ rotation protection	Escape/ rotation protection	Rotation protection, with limit switch set ES	Rotation protection with ES and KAR*
49+stroke	69+stroke	121+stroke	141+stroke

\*Hinged bearing plate KAR, fitted on face F (below).

1) Fitting height for 0-stroke, with Tr 20x4 screw

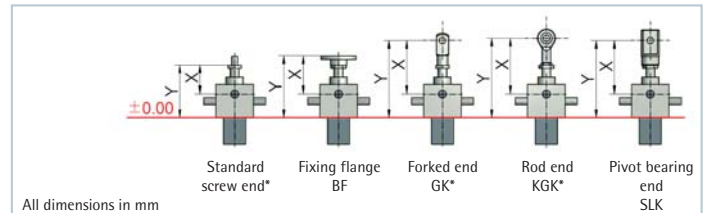

Bellocs FB	X/Y	X/Y	X/Y	X/Y	X/Y
without bellocs FB	59/112	80/133	115/168	120/173	115/168
Z-10-FB-340	140/193	136/189	196/249	201/254	171/224
Z-10-FB-700	160/213	156/209	216/269	221/274	191/244
Z-10-FB-1000	210/263	206/259	266/319	271/324	241/294

\*with bellows fixing ring Z-10-FBR

Standard ratios

Type	Version	Speed	Standard screw <sup>2)</sup>	i	Stroke per drive shaft rotation <sup>5)</sup>
Z-10-SN	Translating	Normal	Tr 20x4	4:1	1.00 mm
Z-10-SL	screw	Low speed		16:1	0.25 mm
Z-10-RN	Rotating	Normal	Tr 20x4	4:1	1.00 mm
Z-10-RL	screw	Low speed		16:1	0.25 mm

Screw jack mounting



Duty cycle thermal limit, for S+R

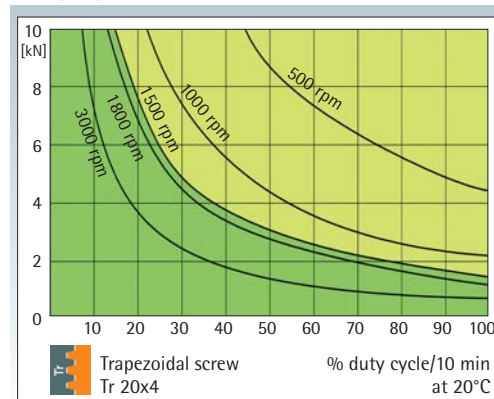

These curves are for guidance under standard industrial conditions (ambient temperature etc.) and correct maintenance (lubrication etc.). The max. input drive torques for optimum service life are at the right page - technical data (1500 rpm)

KGT: % duty cycle 2 times to 4 times higher

Trapezoidal screw

Tr



## Z-10-R rotating screw 10 kN

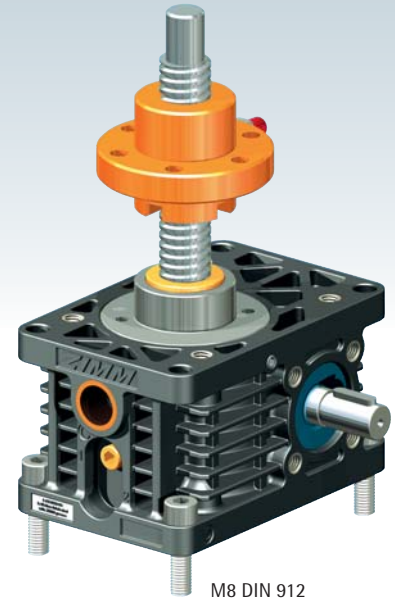
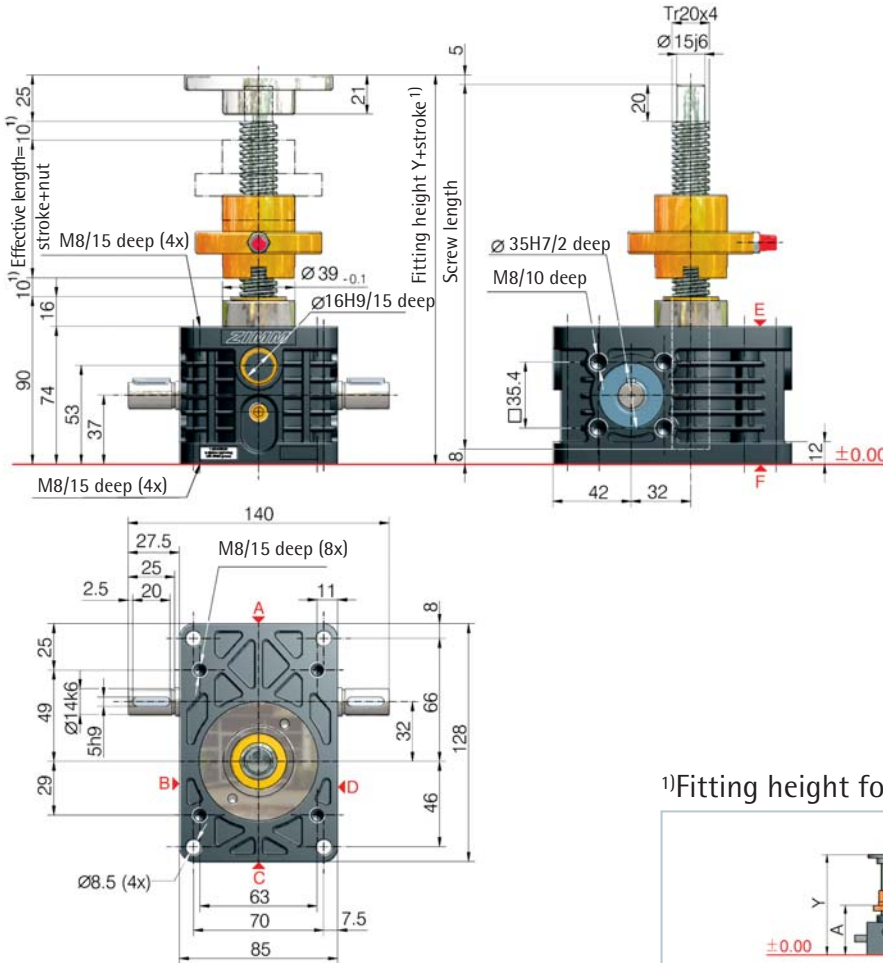

2

# 10

kN

<sup>1)</sup>Fitting height for 0-stroke, with Tr 20x4 screw

All dimensions in mm	Flange nut FM	Duplex nut DM	Duplex nut DM with SIFA	Self-aligning nut PM	Greaseless nut FFDM
<b>Bellocs FB</b>	Y/A	Y/A	Y/A	Y/A	Y/A
without bellows FB	179/112	180/125	219/164	218/159	188/133
2x Z-10-FB-340	-	314/193	350/229	352/227	322/201
2x Z-10-FB-700	-	354/213	390/249	392/247	362/221
2x Z-10-FB-1000	-	454/263	490/299	492/297	462/271

Detailed instructions for determining the length can be found in Section 8

## Technical data series Z-10-S / Z-10-R

max. compressive/tensile force, static	- 10 kN (1 t)
max. compressive/tensile force, dynamic	- see duty cycle curves
Nominal speed	- 1500 rpm
max. drive shaft speed	- 3000 rpm (depending on the load and duty cycle)
Screw size standard	- Tr 20x4 <sup>2)</sup>
Gear ratio	- 4:1 (N) / 16:1 (L)
Housing material	- aluminium, corrosion-resistant
Worm shaft	- steel, case-hardened, ground
Weight of screw jack body	- 2.1 kg
Weight of screw/m	- 2 kg
Gearbox lubrication	- synthetic fluid grease
Screw lubrication	- grease lubrication
Gearbox operating temperature	- max. 60°C, higher on request
Moment of inertia	- N: 0.641 kg cm <sup>2</sup> / L: 0.271 kg cm <sup>2</sup>
Input torque (at 1500 rpm)	- max. 13.5 Nm (N) / max. 7.5 Nm (L)
Drive-through torque	- max. 57 Nm

Drive torque $M_G$ (Nm)	- $F$ (kN) $\times$ 0.64 <sup>3)</sup> + $M_L$ (N-normal)
Breakaway torque	- $F$ (kN) $\times$ 0.20 <sup>3)</sup> + $M_L$ (L-low speed)
Idling torque <sup>4)</sup> $M_L$ (Nm)	- Drive torque $M_G \times 1.5$
	- 0.26 (N-normal) / 0.16 (L-low speed)

Between gearbox and nut or nut and end of thread, provide for a safety distance of (minimum) 10 mm!

See Section 7 for the checklist.

## Important information

- extension if a bellows or spiral spring is fitted: see the table or Section 8
- Tr 20x4 is standard, also available: double-pitch, stainless steel, left-handed, increased screw Tr 30x6 (only for the R version)
- factor includes efficiency, ratio and 30% safety
- at 20°C, can be higher when new
- for a 4 mm screw pitch



Z-25-S translating screw 25 kN

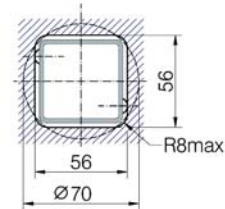
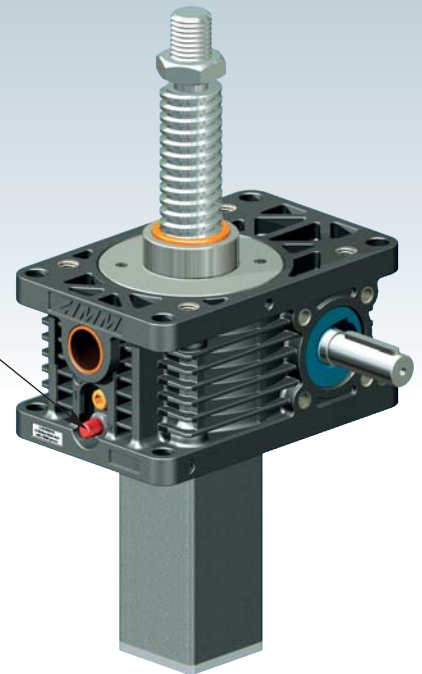
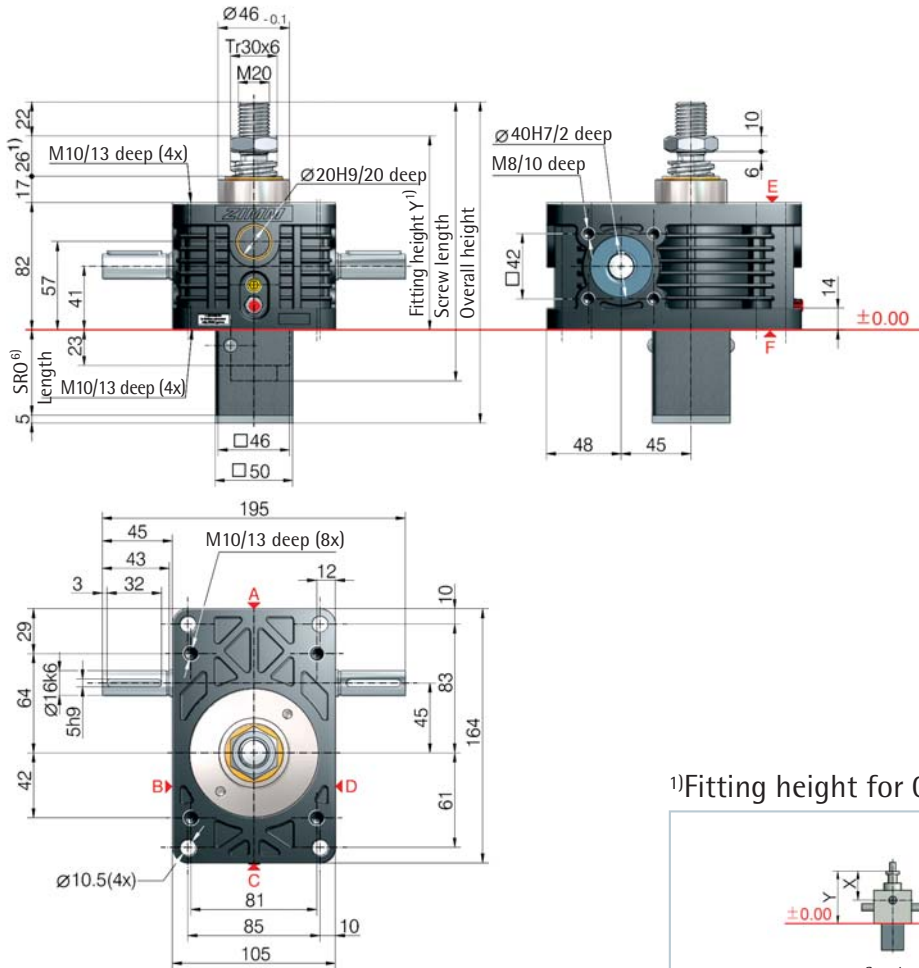

6) Protective tube length SRO with Tr 30x6 screw

Without escape/ rotation protection	Escape/ rotation protection	Rotation protection, with limit switch set ES	Rotation protection with ES and KAR*
53+stroke	73+stroke	125+stroke	149+stroke

\*Hinged bearing plate KAR, fitted on face F (below).

1) Fitting height for 0-stroke, with Tr 30x6 screw

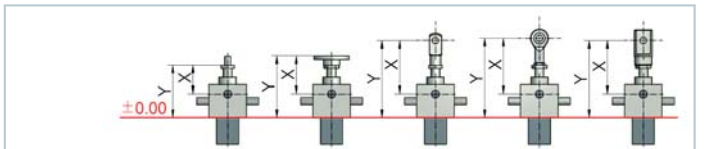

All dimensions in mm

Bellocs FB	X/Y	X/Y	X/Y	X/Y	X/Y
without bellocs FB	68/125	91/148	148/205	145/202	148/205
Z-25-FB-300	143/200	135/192	223/280	220/277	192/249
Z-25-FB-700	173/230	165/222	253/310	250/307	222/279
Z-25-FB-1000	193/250	185/242	273/330	270/327	242/299

\*with bellows fixing ring Z-25-FBR

Standard ratios

Type	Version	Speed	Standard screw <sup>2)</sup>	i	Stroke per drive shaft rotation <sup>5)</sup>
Z-25-SN	Translating	Normal	Tr 30x6	6:1	1.00 mm
Z-25-SL	screw	Low speed		24:1	0.25 mm
Z-25-RN	Rotating	Normal	Tr 30x6	6:1	1.00 mm
Z-25-RL	screw	Low speed		24:1	0.25 mm

Screw jack mounting



Duty cycle thermal limit, for S+R

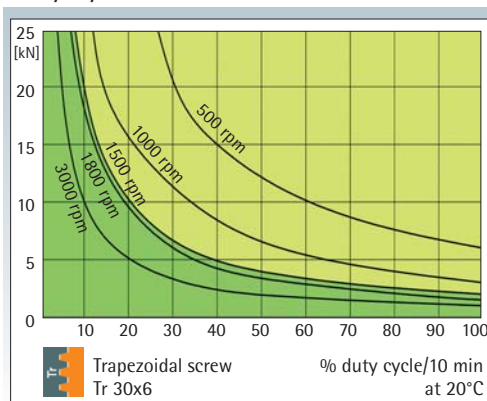

These curves are for guidance under standard industrial conditions (ambient temperature etc.) and correct maintenance (lubrication etc.). The max. input drive torques for optimum service life are at the right page - technical data (1500 rpm)

KGT: % duty cycle 2 times to 4 times higher

Trapezoidal screw

Tr



## Z-25-R rotating screw 25 kN

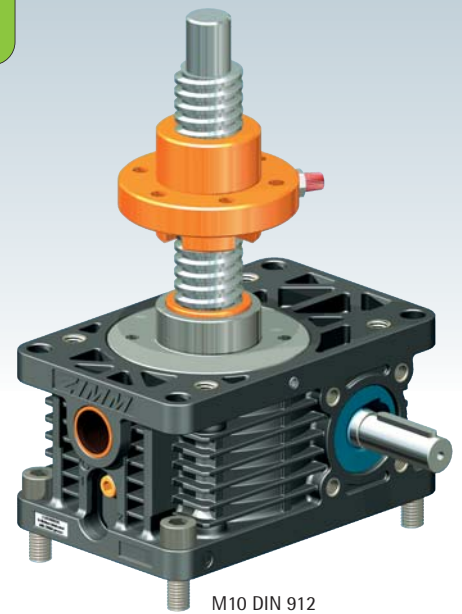

M10 DIN 912

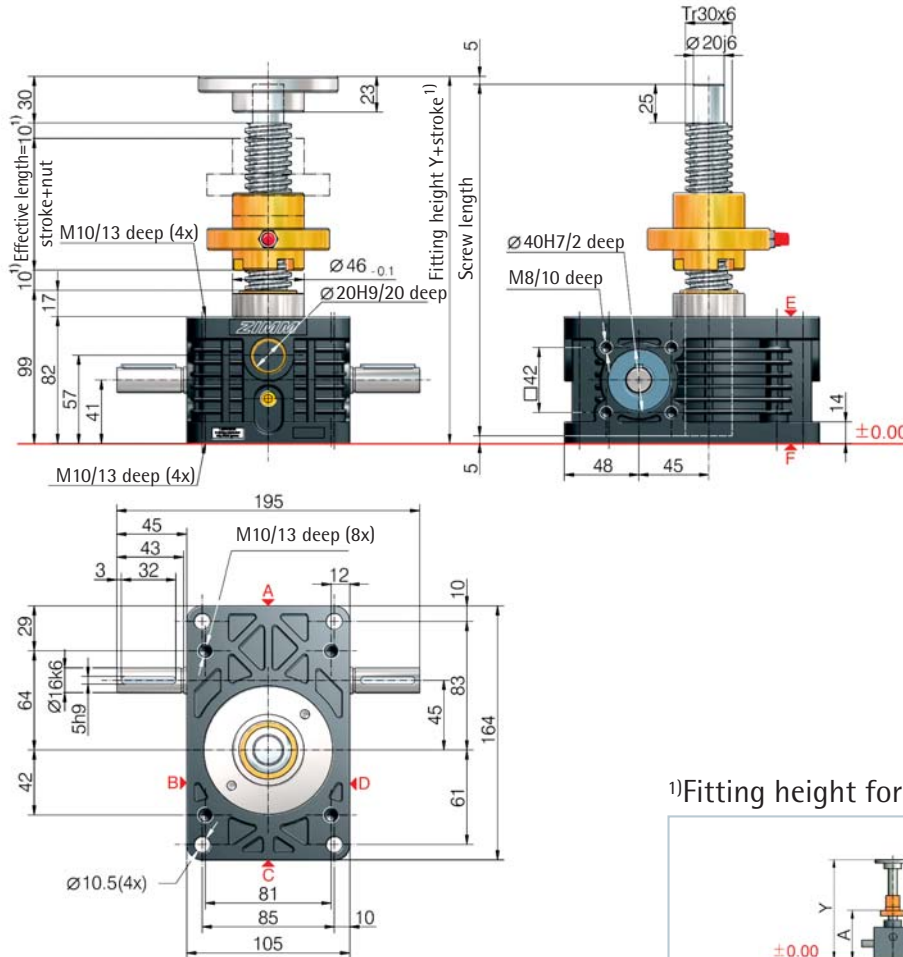

$1^1$ Fitting height for 0-stroke, with Tr 30x6 screw

All dimensions in mm	Flange nut FM	Duplex nut DM	Duplex nut DM with SIFA	Self-aligning nut PM	Greaseless nut FFDM
<b>Bellows FB</b>	Y/A	Y/A	Y/A	Y/A	Y/A
without bellows FB	195/123	199/136	244/181	244/177	208/145
2x Z-25-FB-300	-	314/196	353/235	359/237	325/207
2x Z-25-FB-700	-	374/226	413/265	419/267	385/237
2x Z-25-FB-1000	-	414/246	453/285	459/287	425/257

Detailed instructions for determining the length can be found in Section 8

# 25 kN

## Technical data series Z-25-S / Z-25-R

max. compressive/tensile force, static	- 25 kN (2.5 t)
max. compressive/tensile force, dynamic	- see duty cycle curves
Nominal speed	- 1500 rpm
max. drive shaft speed	- 3000 rpm (depending on the load and duty cycle)
Screw size standard	- Tr 30x6 <sup>3)</sup>
Gear ratio	- 6:1 (N) / 24:1 (L)
Housing material	- aluminium, corrosion-resistant
Worm shaft	- steel, case-hardened, ground
Weight of screw jack body	- 3.8 kg
Weight of screw/m	- 4.5 kg
Gearbox lubrication	- synthetic fluid grease
Screw lubrication	- grease lubrication
Gearbox operating temperature	- max. 60°C, higher on request
Moment of inertia	- N: 1.449 kg cm <sup>2</sup> / L: 0.589 kg cm <sup>2</sup>
Input torque (at 1500 rpm)	- max. 18 Nm (N) / max. 10 Nm (L)
Drive-through torque	- max. 108 Nm

Drive torque $M_G$ (Nm)	- $F$ (kN) $\times$ 0.63 <sup>3)</sup> + $M_L$ (N-normal)
Breakaway torque	- $F$ (kN) $\times$ 0.20 <sup>3)</sup> + $M_L$ (L-low speed)
Idling torque <sup>4)</sup> $M_L$ (Nm)	- Drive torque $M_G$ $\times$ 1.5
	- 0.36 (N-normal) / 0.26 (L-low speed)

Between gearbox and nut or nut and end of thread, provide for a safety distance of (minimum) 10 mm!

See Section 7 for the checklist.

## Important information

- extension if a bellows or spiral spring is fitted: see the table or Section 8
- Tr 30x6 is standard, also available: double-pitch, stainless steel, left-handed, increased screw Tr 40x7 (only for the R version)
- factor includes efficiency, ratio and 30% safety
- at 20°C, can be higher when new
- for a 6 mm screw pitch



UNIQUE:  
Screw lubrication  
during operation

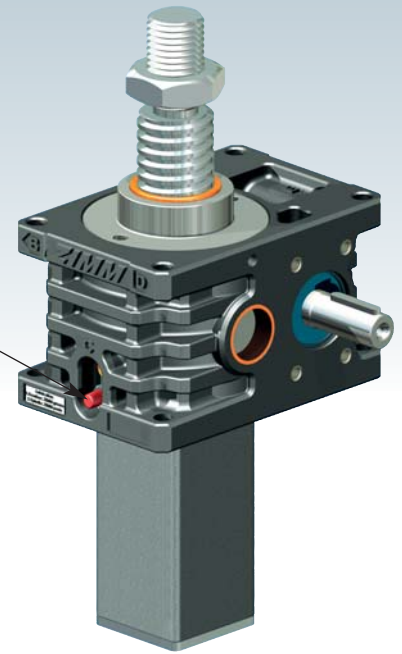

Z-35-S translating screw 35 kN

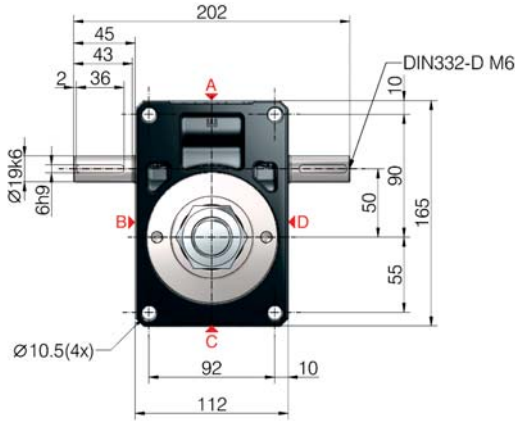
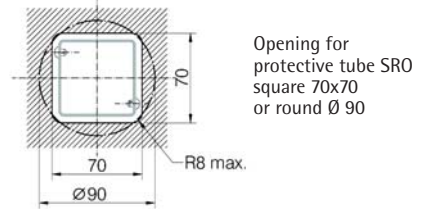
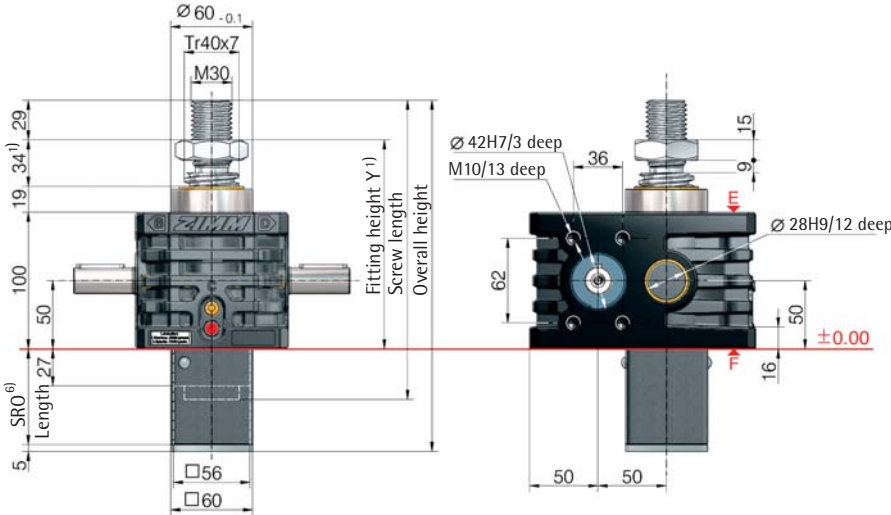

1) Fitting height for 0-stroke, with Tr 40x7 screw

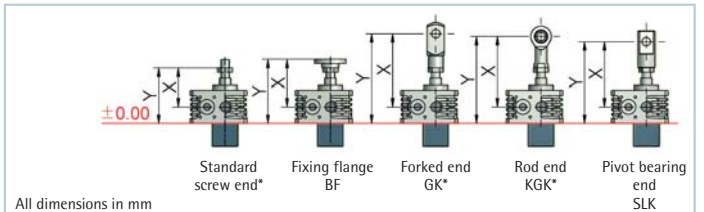

All dimensions in mm

Bellocs FB	X/Y	X/Y	X/Y	X/Y	X/Y
without bellocs FB	103/153	133/183	223/273	213/263	195/245
Z-50-FB-390	198/248	182/232	318/368	308/358	244/294
Z-50-FB-600	185/235	169/219	305/355	295/345	231/281
Z-50-FB-1000	243/293	227/277	363/413	353/403	289/339
Z-50-FB-1200	238/288	222/272	358/408	348/398	284/334
Z-50-FB-1500	293/343	277/327	413/463	403/453	339/389

\*with bellocs fixing ring Z-50-FBR

6) Protective tube length SRO with Tr 40x7 screw

Without escape/rotation protection	Escape/rotation protection	Rotation protection, with limit switch set ES
57+stroke	87+stroke	143+stroke

Standard ratios

Type	Version	Speed	Standard screw <sup>2)</sup>	i	Stroke per drive shaft rotation <sup>5)</sup>
Z-35-SN	Translating	Normal	Tr 40x7	7:1	1.00 mm
Z-35-SL	screw	Low speed		28:1	0.25 mm
Z-35-RN	Rotating	Normal	Tr 40x7	7:1	1.00 mm
Z-35-RL	screw	Low speed		28:1	0.25 mm

Screw jack mounting



Duty cycle thermal limit, for S+R

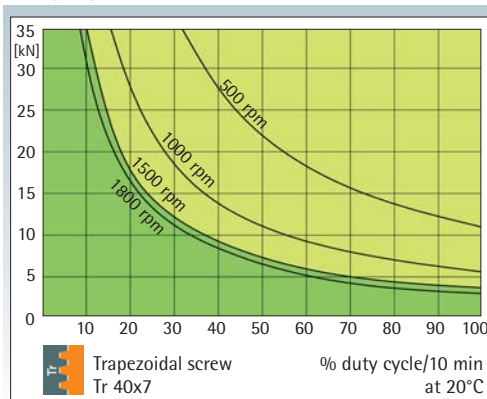

These curves are for guidance under standard industrial conditions (ambient temperature etc.) and correct maintenance (lubrication etc.). The max. input drive torques for optimum service life are at the right page - technical data (1500 rpm)

KGT:  
% duty cycle  
2 times to  
4 times higher

Trapezoidal screw

Tr



## Z-35-R rotating screw 35 kN

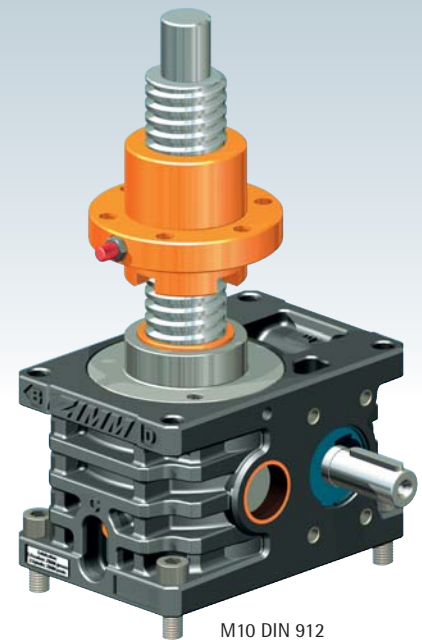
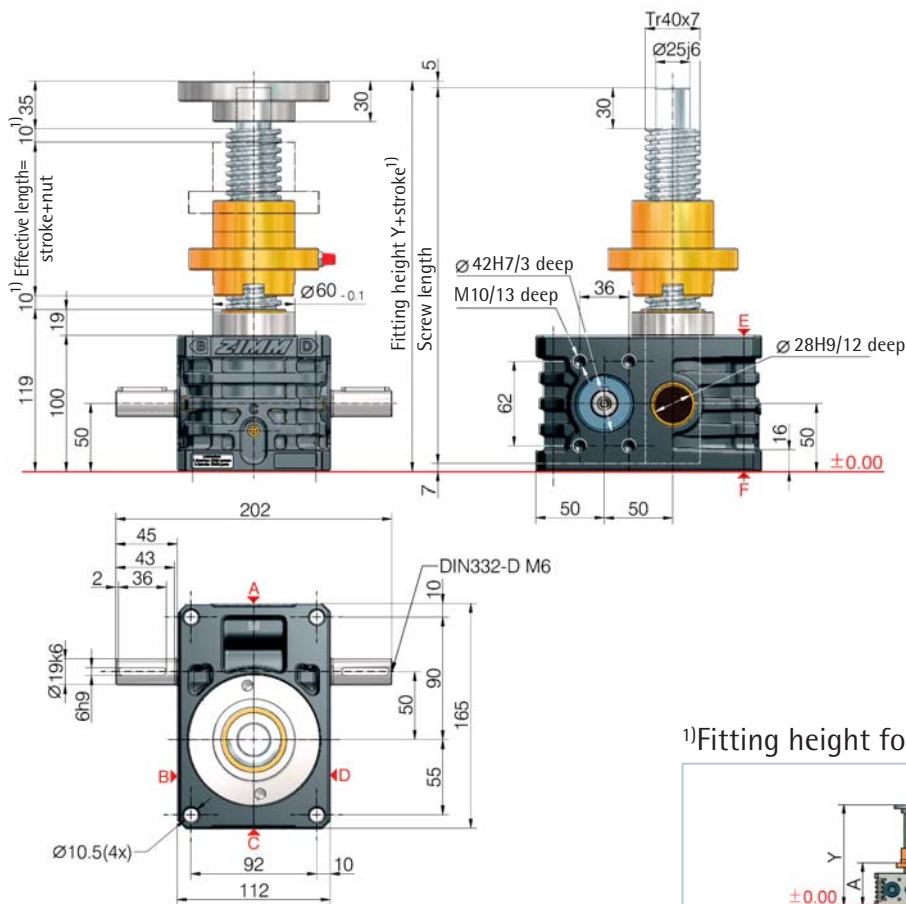

M10 DIN 912

2

## 1) Fitting height for 0-stroke, with Tr 40x7 screw

All dimensions in mm	Flange nut FM	Duplex nut DM	Duplex nut DM with SIFA	Self-aligning nut PM	Greaseless nut FFDM
Bellows FB	Y/A	Y/A	Y/A	Y/A	Y/A
without bellows FB	240/145	244/163	307/226	303/228	259/179
2x Z-50-FB-390	-	387/236	446/295	446/301	404/254
2x Z-50-FB-600	-	361/223	420/282	420/288	378/241
2x Z-50-FB-1000	-	477/281	536/340	536/346	494/299
2x Z-50-FB-1200	-	467/276	526/335	526/341	484/294
2x Z-50-FB-1500	-	577/331	636/390	636/396	594/349

Detailed instructions for determining the length can be found in Section 8

# 35

kN

## Technical data series Z-35-S / Z-35-R

max. compressive/tensile force, static	- 35 kN (3.5 t)
max. compressive/tensile force, dynamic	- see duty cycle curves
Nominal speed	- 1500 rpm
max. drive shaft speed	- 1800 rpm
Screw size standard	- Tr 40x7 <sup>2)</sup>
Gear ratio	- 7:1 (N) / 28:1 (L)
Housing material	- GGG-50, corrosion-resistant
Worm shaft	- steel, case-hardened, ground
Weight of screw jack body	- 9.5 kg
Weight of screw/m	- 8 kg
Gearbox lubrication	- synthetic fluid grease
Screw lubrication	- grease lubrication
Gearbox operating temperature	- max. 60°C, higher on request
Moment of inertia	- N: 2.18 kg cm <sup>2</sup> / L: 0.90 kg cm <sup>2</sup>
Input torque (at 1500 rpm)	- max. 19.8 Nm (N) / max. 9 Nm (L)
Drive-through torque	- max. 130 Nm

Drive torque $M_G$ (Nm)	- $F$ (kN) $\times$ 0.69 <sup>3)5)</sup> + $M_L$ (N-normal) - $F$ (kN) $\times$ 0.23 <sup>3)5)</sup> + $M_L$ (L-low speed)
Breakaway torque	- Drive torque $M_G \times 1.5$
Idling torque <sup>4)</sup> $M_L$ (Nm)	- 0.56 (N-normal) / 0.40 (L-low speed)

Between gearbox and nut or nut and end of thread, provide for a safety distance of (minimum) 10 mm!

See Section 7 for the checklist.

## Important information

- extension if a bellows or spiral spring is fitted: see the table or Section 8
- Tr 40x7 is standard, also available: double-pitch, stainless steel, left-handed, increased screw Tr 55x9 (only for the R version)
- factor includes efficiency, ratio and 30% safety
- at 20°C, can be higher when new
- for a 7 mm screw pitch



UNIQUE:  
Screw lubrication  
during operation

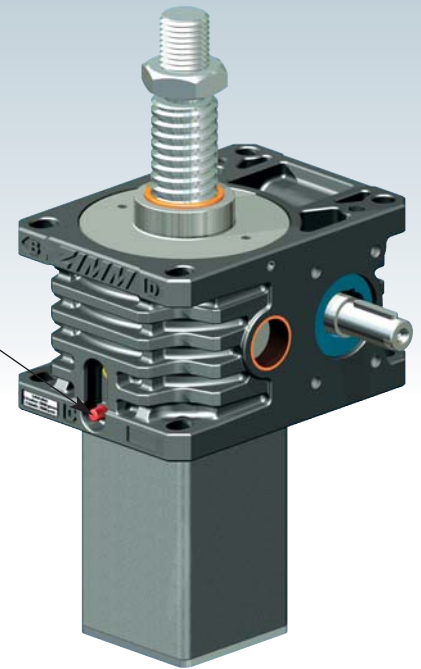

Z-50-S translating screw 50 kN

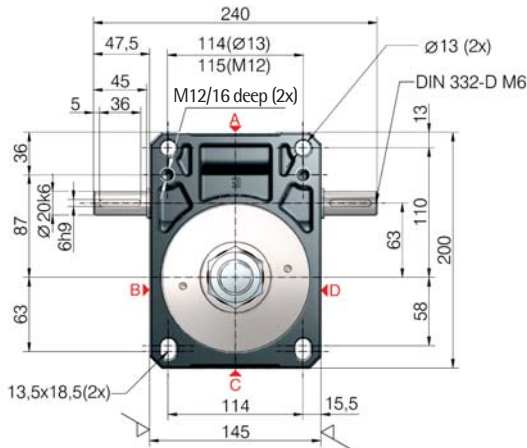
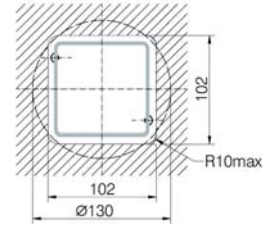
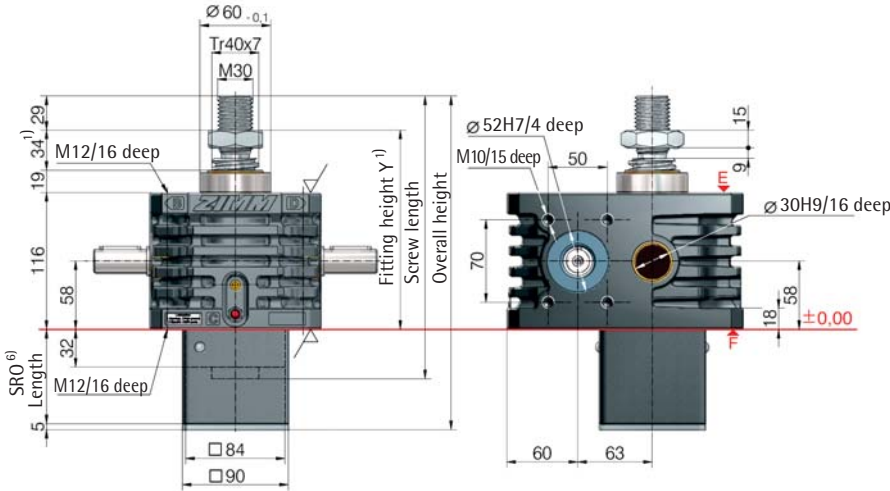

<sup>1)</sup>Fitting height for 0-stroke, with Tr 40x7 screw

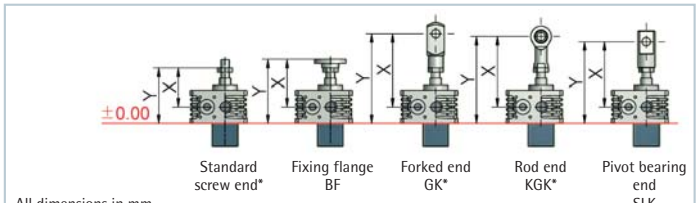

Bellocs FB	X/Y	X/Y	X/Y	X/Y	X/Y
without bellocs FB	111/169	141/199	231/289	221/279	203/261
Z-50-FB-390	206/264	190/248	326/384	316/374	252/310
Z-50-FB-600	193/251	177/235	313/371	303/361	239/297
Z-50-FB-1000	251/309	235/293	371/429	361/419	297/355
Z-50-FB-1200	246/304	230/288	366/424	356/414	292/350
Z-50-FB-1500	301/359	285/343	421/479	411/469	347/405

\*with bellocs fixing ring Z-50-FBR

<sup>6)</sup>Protective tube length SRO with Tr 40x7 screw

Without escape/rotation protection	Escape/rotation protection	Rotation protection, with limit switch set ES
62+stroke	92+stroke	144+stroke

Standard ratios

Type	Version	Speed	Standard screw <sup>2)</sup>	i	Stroke per drive shaft rotation <sup>5)</sup>
Z-50-SN	Translating	Normal	Tr 40x7	7:1	1.00 mm
Z-50-SL	screw	Low speed		28:1	0.25 mm
Z-50-RN	Rotating	Normal	Tr 40x7	7:1	1.00 mm
Z-50-RL	screw	Low speed		28:1	0.25 mm

Screw jack mounting



Duty cycle thermal limit, for S+R

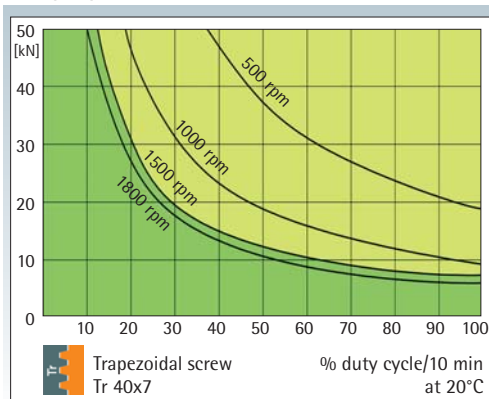

These curves are for guidance under standard industrial conditions (ambient temperature etc.) and correct maintenance (lubrication etc.). The max. input drive torques for optimum service life are at the right page - technical data (1500 rpm)

KGK: % duty cycle 2 times to 4 times higher



Trapezoidal screw

Tr



## Z-50-R rotating screw 50 kN

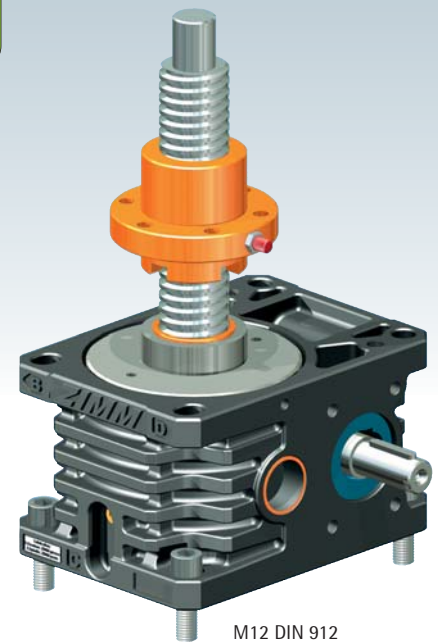
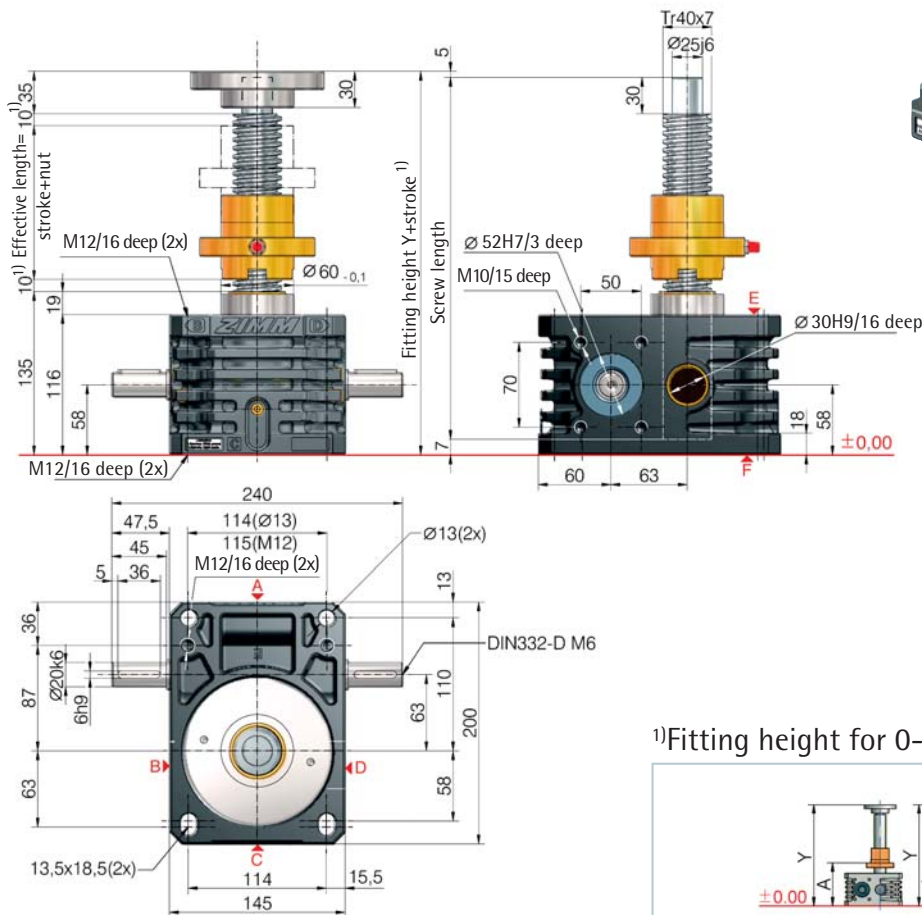

M12 DIN 912

2

1) Fitting height for 0-stroke, with Tr 40x7 screw

All dimensions in mm	Flange nut FM	Duplex nut DM	Duplex nut DM with SIFA	Self-aligning nut PM	Greaseless nut FFDM
<b>Bellows FB</b>	Y/A	Y/A	Y/A	Y/A	Y/A
without bellows FB	256/161	260/179	323/242	319/244	275/195
2x Z-50-FB-390	-	403/252	462/311	462/317	420/270
2x Z-50-FB-600	-	377/239	436/298	436/304	394/257
2x Z-50-FB-1000	-	493/297	552/356	552/362	510/315
2x Z-50-FB-1200	-	483/292	542/351	542/357	500/310
2x Z-50-FB-1500	-	593/347	652/406	652/412	610/365

Detailed instructions for determining the length can be found in Section 8

# 50 kN

## Technical data series Z-50-S / Z-50-R

max. compressive/tensile force, static	- 50 kN (5 t)
max. compressive/tensile force, dynamic	- see duty cycle curves
Nominal speed	- 1500 rpm
max. drive shaft speed	- 1800 rpm
Screw size standard	- Tr 40x7 <sup>2)</sup>
Gear ratio	- 7:1 (N) / 28:1 (L)
Housing material	- GGG-50, corrosion-resistant
Worm shaft	- steel, case-hardened, ground
Weight of screw jack body	- 17 kg
Weight of screw/m	- 8 kg
Gearbox lubrication	- synthetic fluid grease
Screw lubrication	- grease lubrication
Gearbox operating temperature	- max. 60°C, higher on request
Moment of inertia	- N: 6.40 kg cm <sup>2</sup> / L: 2.53 kg cm <sup>2</sup>
Input torque (at 1500 rpm)	- max. 31.5 Nm (N) / max. 10.4 Nm (L)
Drive-through torque	- max. 260 Nm

Drive torque $M_G$ (Nm)	- $F$ (kN) $\times$ 0.68 <sup>3)5)</sup> + $M_L$ (N-normal) - $F$ (kN) $\times$ 0.23 <sup>3)5)</sup> + $M_L$ (L-low speed)
Breakaway torque	- Drive torque $M_G \times 1.5$
Idling torque <sup>4)</sup> $M_L$ (Nm)	- 0.76 (N-normal) / 0.54 (L-low speed)

Between gearbox and nut or nut and end of thread, provide for a safety distance of (minimum) 10 mm!

See Section 7 for the checklist.

## Important information

- extension if a bellows or spiral spring is fitted: see the table or Section 8
- Tr 40x7 is standard, also available: double-pitch, stainless steel, left-handed, increased screw Tr 55x9 (only for the R version)
- factor includes efficiency, ratio and 30% safety
- at 20°C, can be higher when new
- for a 7 mm screw pitch



Z-50/Tr50-S translating screw 50 kN

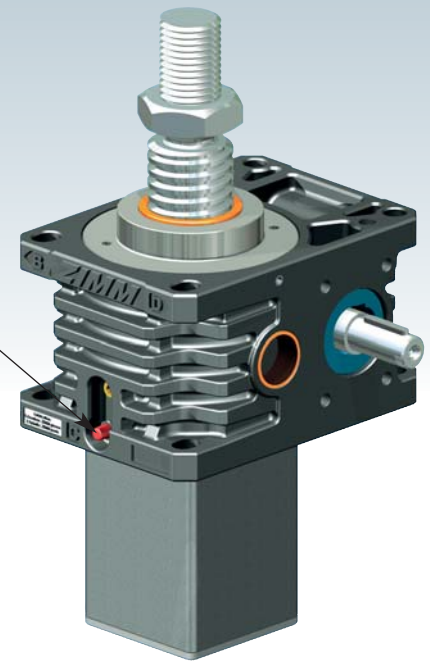

UNIQUE:  
Screw lubrication  
during operation

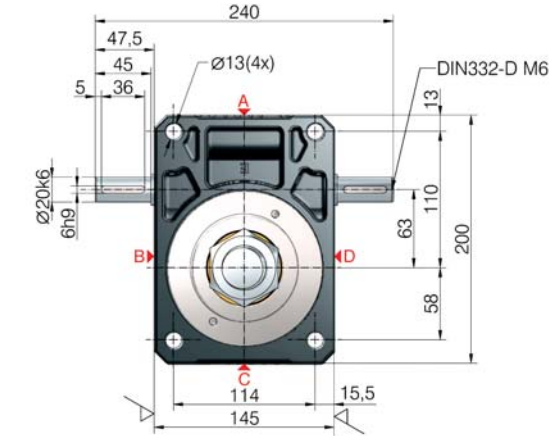
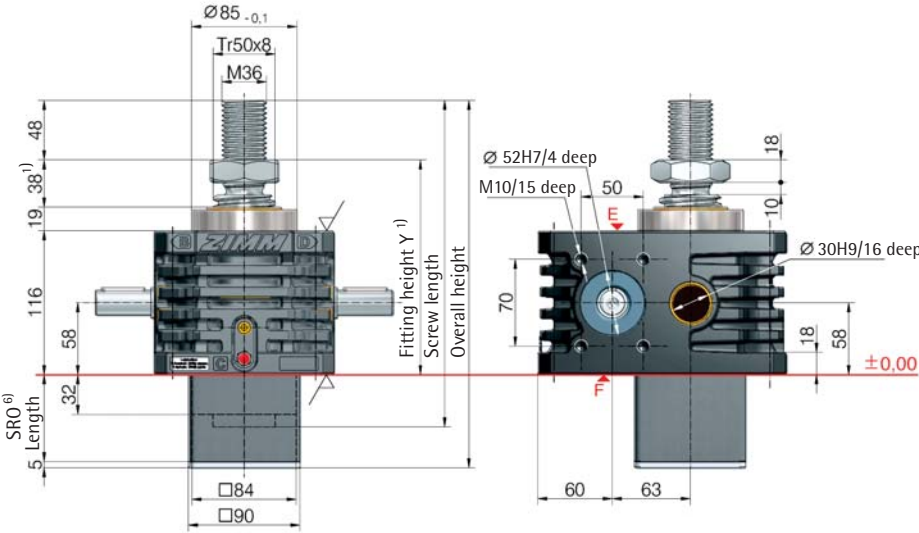

**i** For Z-50/Tr50, use screw-related accessories from the Z-100.

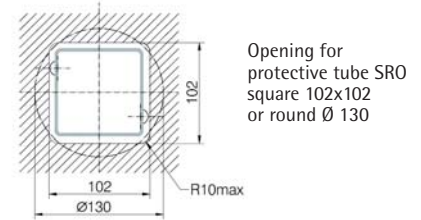

6) Protective tube length SRO with Tr 50x8 screw

Without escape/rotation protection	Escape/rotation protection	Rotation protection, with limit switch set ES
62+stroke	92+stroke	144+stroke

1) Fitting height for 0-stroke, with Tr 50x8 screw

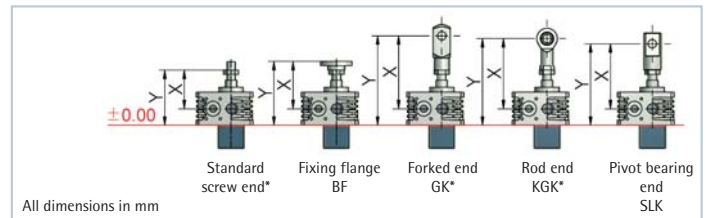

All dimensions in mm

Bellocs FB	X/Y	X/Y	X/Y	X/Y	X/Y
without bellocs FB	115/173	165/223	259/317	257/315	223/281
Z-100-FB-285	198/256	200/258	342/400	340/398	258/316
Z-100-FB-600	195/253	197/255	339/397	337/395	255/313
Z-100-FB-1000	253/311	255/313	397/455	395/453	313/371
Z-100-FB-1500	303/361	305/363	447/505	445/503	363/421

\*with bellows fixing ring Z-100-FBR

Standard ratios

Type	Version	Speed	Standard screw <sup>2)</sup>	i	Stroke per drive shaft rotation <sup>5)</sup>
Z-50/Tr50-SN	Translating	Normal	Tr 50x8	7:1	1.143 mm
Z-50/Tr50-SL	screw	Low speed		28:1	0.286 mm

Screw jack mounting



Duty cycle thermal limit, for S

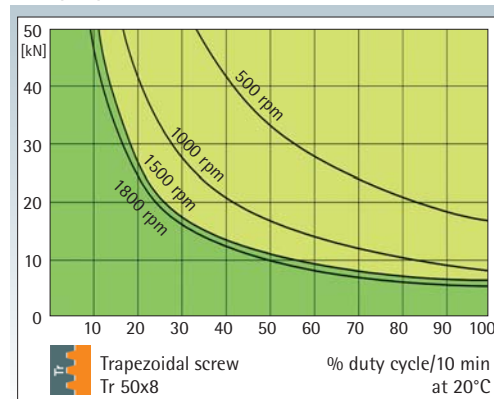

These curves are for guidance under standard industrial conditions (ambient temperature etc.) and correct maintenance (lubrication etc.). The max. input drive torques for optimum service life are at the right page - technical data (1500 rpm)

**KGT:**  
% duty cycle  
2 times to  
4 times higher

## Z-35 + Z-50/Tr50 heavy duty screws for long strokes

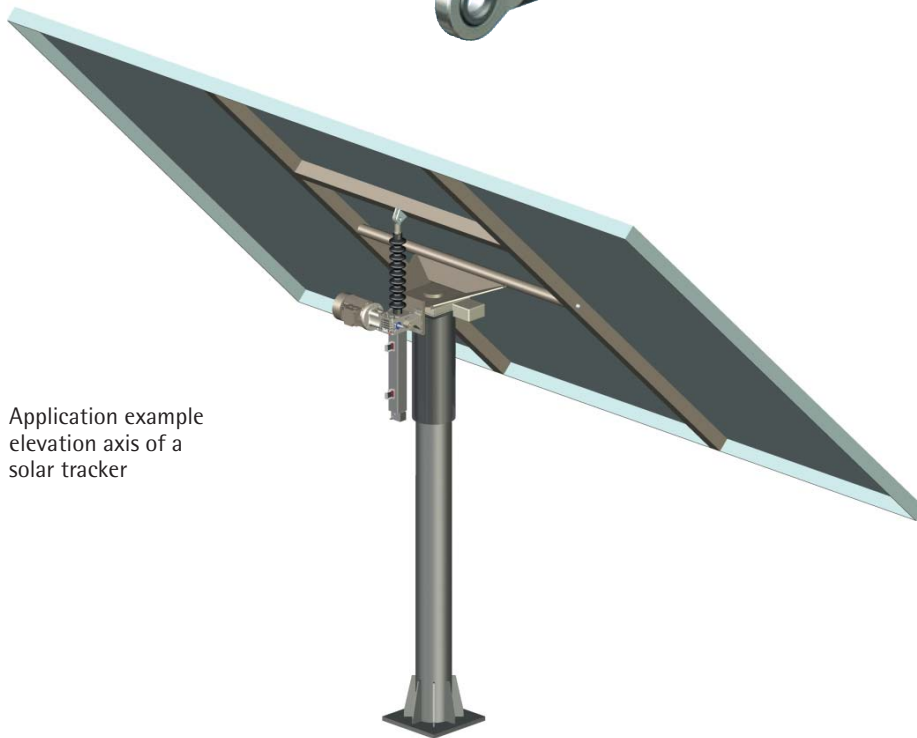
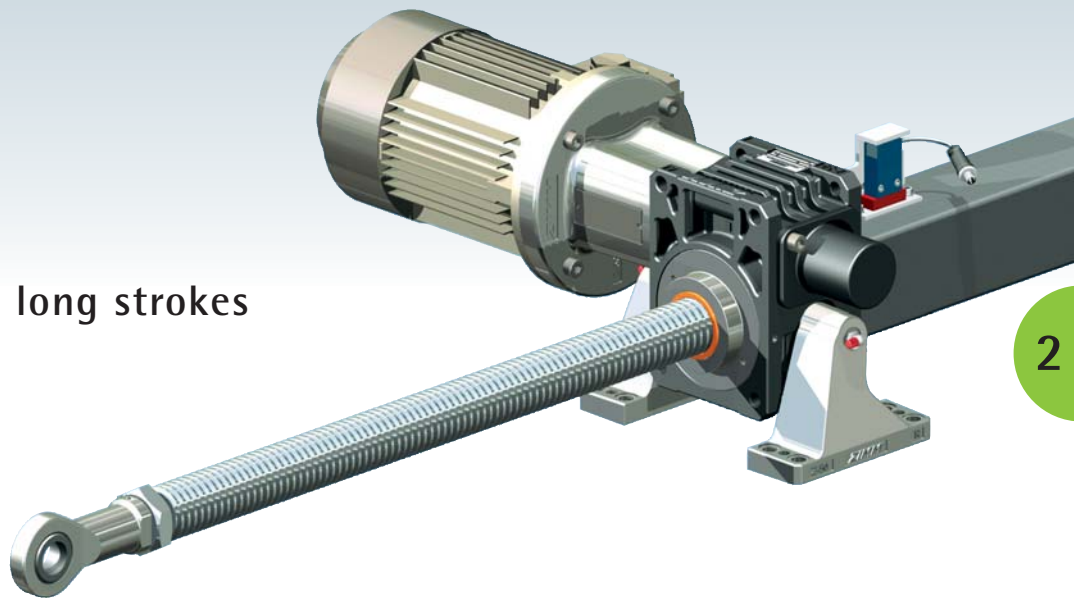

Application example  
elevation axis of a  
solar tracker

### Heavy duty screws

The screw diameter is a critical factor in long-stroke applications. Long-stroke screws have to be oversized to prevent buckling and other problems. However, increasing the diameter of the screw means that the gearbox also has to be oversized accordingly.

To overcome this problem, the Z-35 and the Z-50/Tr50 are specially designed with stronger screws to prevent buckling on applications with long strokes. The screw does not therefore require oversizing and consequently a compact gearbox can also be used on long-stroke applications.

Z-35:                   with Tr 40x7 screw  
Z-50/Tr50:           with Tr 50x8 screw

# 50 kN

### Technical data series Z-50/Tr50-S

max. compressive/tensile force, static	- 50 kN (5 t)
max. compressive/tensile force, dynamic	- see duty cycle curves
Nominal speed	- 1500 rpm
max. drive shaft speed	- 1800 rpm
Screw size standard	- Tr 50x8 <sup>2)</sup>
Gear ratio	- 7:1 (N) / 28:1 (L)
Housing material	- GGG-50, corrosion-resistant
Worm shaft	- steel, case-hardened, ground
Weight of screw jack body	- 17 kg
Weight of screw/m	- 13 kg
Gearbox lubrication	- synthetic fluid grease
Screw lubrication	- grease lubrication
Gearbox operating temperature	- max. 60°C, higher on request
Moment of inertia	- N: 6.65 kg cm <sup>2</sup> / L: 2.62 kg cm <sup>2</sup>
Input torque (at 1500 rpm)	- max. 31.5 Nm (N) / max. 10.4 Nm (L)
Drive-through torque	- max. 260 Nm

Drive torque $M_G$ (Nm)	- $F$ (kN) $\times$ 0.86 <sup>3)5)</sup> + $M_L$ (N-normal)
Breakaway torque	- $F$ (kN) $\times$ 0.29 <sup>3)5)</sup> + $M_L$ (L-low speed)
Idling torque <sup>4)</sup> $M_L$ (Nm)	- Drive torque $M_G$ $\times$ 1.5
	- 0.76 (N-normal) / 0.54 (L-low speed)

Between gearbox and nut or nut and end of thread, provide for a safety distance of (minimum) 10 mm!  
See Section 7 for the checklist.

#### Important information

- 1) - extension if a bellows or spiral spring is fitted: see the table or Section 8
- 2) - Tr 50x8 is standard, also available: double-pitch, stainless steel, left-handed
- 3) - factor includes efficiency, ratio and 30% safety
- 4) - at 20°C, can be higher when new
- 5) - for a 8 mm screw pitch



Z-100-S translating screw 100 kN

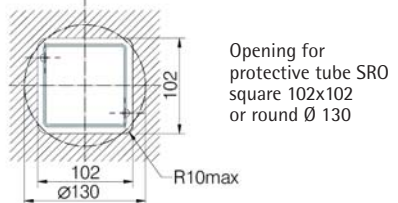
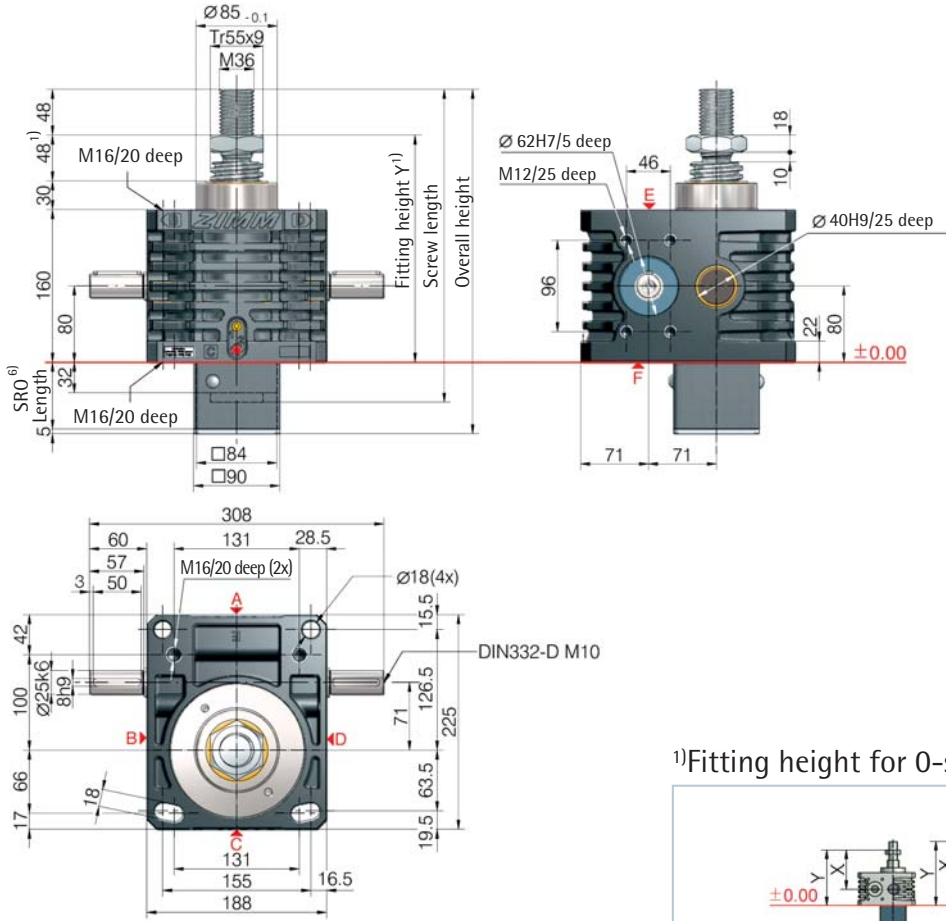
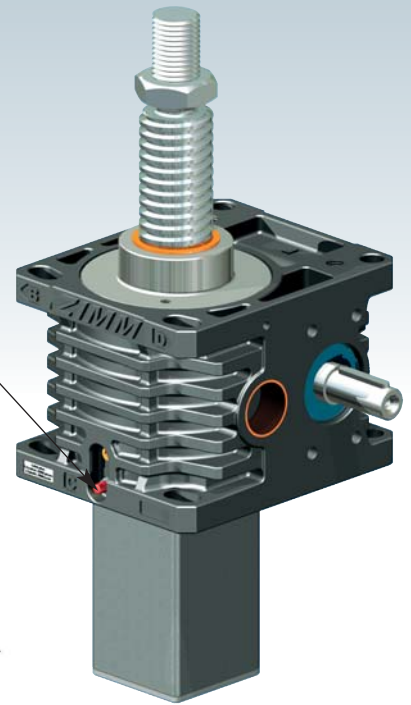

6) Protective tube length SRO with Tr 55x9 screw

Without escape/rotation protection	Escape/rotation protection	Rotation protection, with limit switch set ES
82+stroke	112+stroke	144+stroke

1) Fitting height for 0-stroke, with Tr 55x9 screw

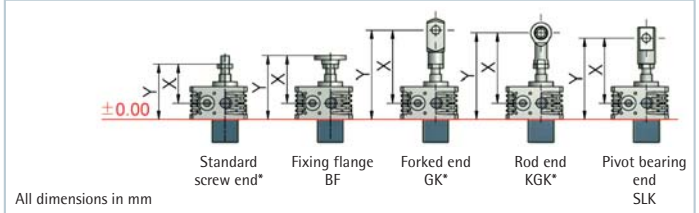

Bellocs FB	X/Y	X/Y	X/Y	X/Y	X/Y
without bellocs FB	158/238	208/288	302/382	300/380	266/346
Z-100-FB-285	231/311	233/313	375/455	373/453	291/371
Z-100-FB-600	228/308	230/310	372/452	370/450	288/368
Z-100-FB-1000	286/366	288/368	430/510	428/508	346/426
Z-100-FB-1500	336/416	338/418	480/560	478/558	396/476

\*with bellows fixing ring Z-100-FBR

Standard ratios

Type	Version	Speed	Standard screw <sup>2)</sup>	i	Stroke per drive shaft rotation <sup>5)</sup>
Z-100-SN	Translating	Normal	Tr 55x9	9:1	1.00 mm
Z-100-SL	screw	Low speed		36:1	0.25 mm
Z-100-RN	Rotating	Normal	Tr 55x9	9:1	1.00 mm
Z-100-RL	screw	Low speed		36:1	0.25 mm

Screw jack mounting



Duty cycle thermal limit, for S+R

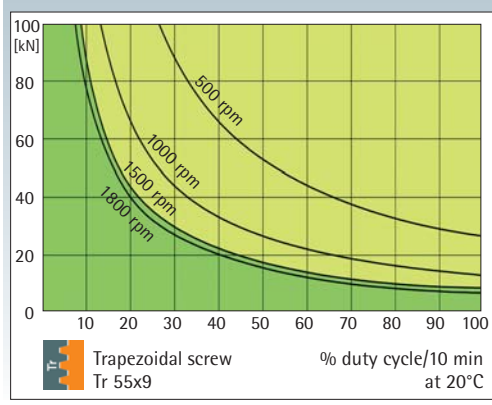

These curves are for guidance under standard industrial conditions (ambient temperature etc.) and correct maintenance (lubrication etc.). The max. input drive torques for optimum service life are at the right page - technical data (1500 rpm)

KGT: % duty cycle 2 times to 4 times higher

Trapezoidal screw

Tr



## Z-100-R rotating screw 100 kN

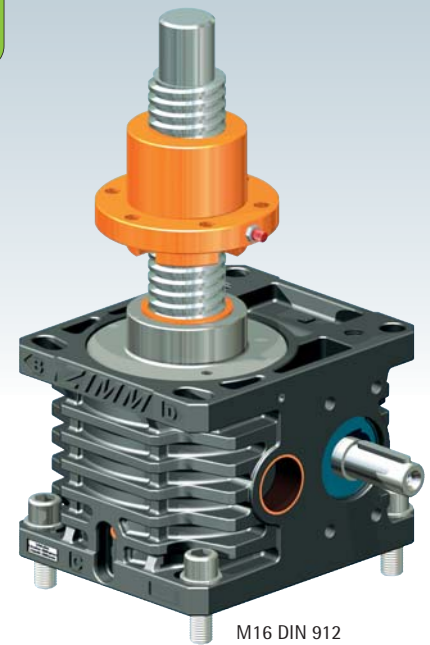
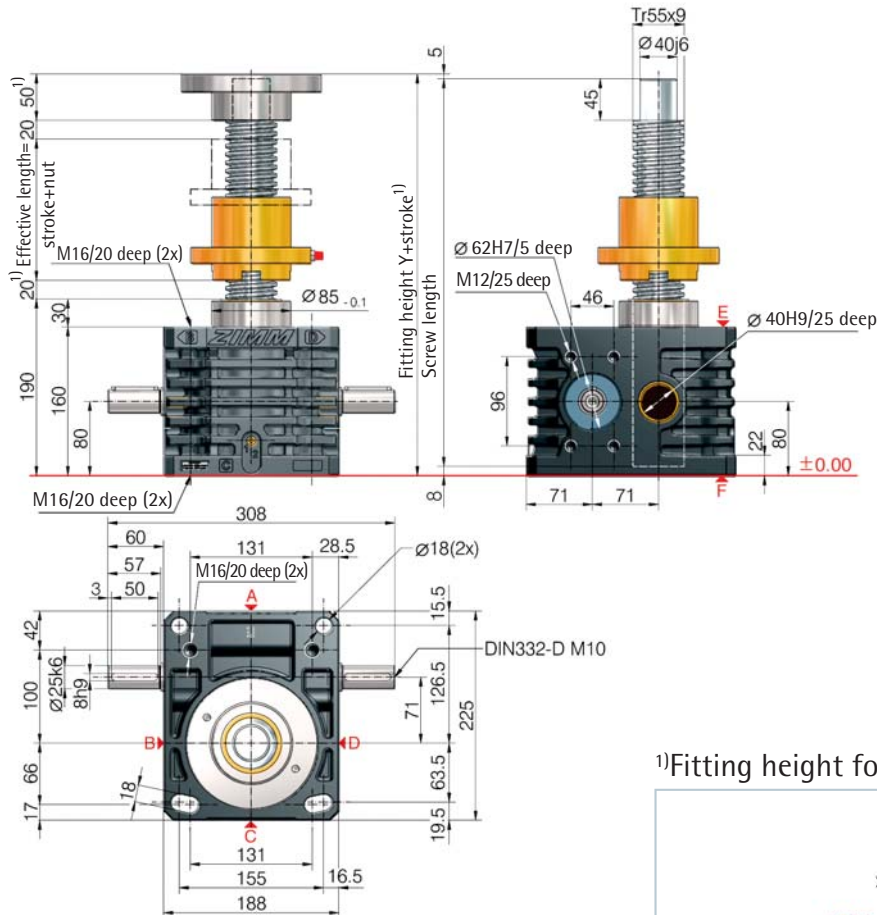

M16 DIN 912

2

<sup>1)</sup>Fitting height for 0-stroke, with Tr 55x9 screw

All dimensions in mm	Duplex nut DM	Duplex nut DM with SIFA	Self-aligning nut PM
<b>Bellocs FB</b>	<b>Y/A</b>	<b>Y/A</b>	<b>Y/A</b>
without bellows FB	370/246	453/329	470/355
2x Z-100-FB-285	478/299	556/377	578/408
2x Z-100-FB-600	472/296	550/374	572/405
2x Z-100-FB-1000	588/354	666/432	688/463
2x Z-100-FB-1500	688/404	766/482	788/513

Detailed instructions for determining the length can be found in Section 8

# 100

 kN

## Technical data series Z-100-S / Z-100-R

max. compressive/tensile force, static	- 100 kN (10 t)
max. compressive/tensile force, dynamic	- see duty cycle curves
Nominal speed	- 1500 rpm
max. drive shaft speed	- 1800 rpm
Screw size standard	- Tr 55x9 <sup>2)</sup>
Gear ratio	- 9:1 (N) / 36:1 (L)
Housing material	- GGG-50, corrosion-resistant
Worm shaft	- steel, case-hardened, ground
Weight of screw jack body	- 29 kg
Weight of screw/m	- 15.7 kg
Gearbox lubrication	- synthetic fluid grease
Screw lubrication	- grease lubrication
Gearbox operating temperature	- max. 60°C, higher on request
Moment of inertia	- N: 12.53 kg cm <sup>2</sup> / L: 4.75 kg cm <sup>2</sup>
Input torque (at 1500 rpm)	- max. 53.4 Nm (N) / max. 13.5 Nm (L)
Drive-through torque	- max. 540 Nm

Drive torque $M_G$ (Nm)	- $F$ (kN) $\times$ 0.72 <sup>3)5)</sup> + $M_L$ (N-normal)
Breakaway torque	- $F$ (kN) $\times$ 0.23 <sup>3)5)</sup> + $M_L$ (L-low speed)
Idling torque <sup>4)</sup> $M_L$ (Nm)	- Drive torque $M_G$ $\times$ 1.5
	- 1.68 (N-normal) / 1.02 (L-low speed)

Between gearbox and nut or nut and end of thread, provide for a safety distance of (minimum) 20 mm!

See Section 7 for the checklist.

## Important information

- extension if a bellows or spiral spring is fitted: see the table or Section 8
- Tr 55x9 is standard, also available: double-pitch, stainless steel, left-handed, increased screw Tr 60x9 (only for the R version)
- factor includes efficiency, ratio and 30% safety
- at 20°C, can be higher when new
- for a 9 mm screw pitch



Z-150-S translating screw 150 kN

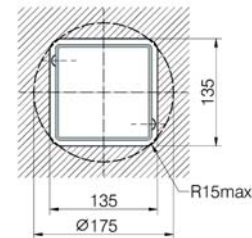
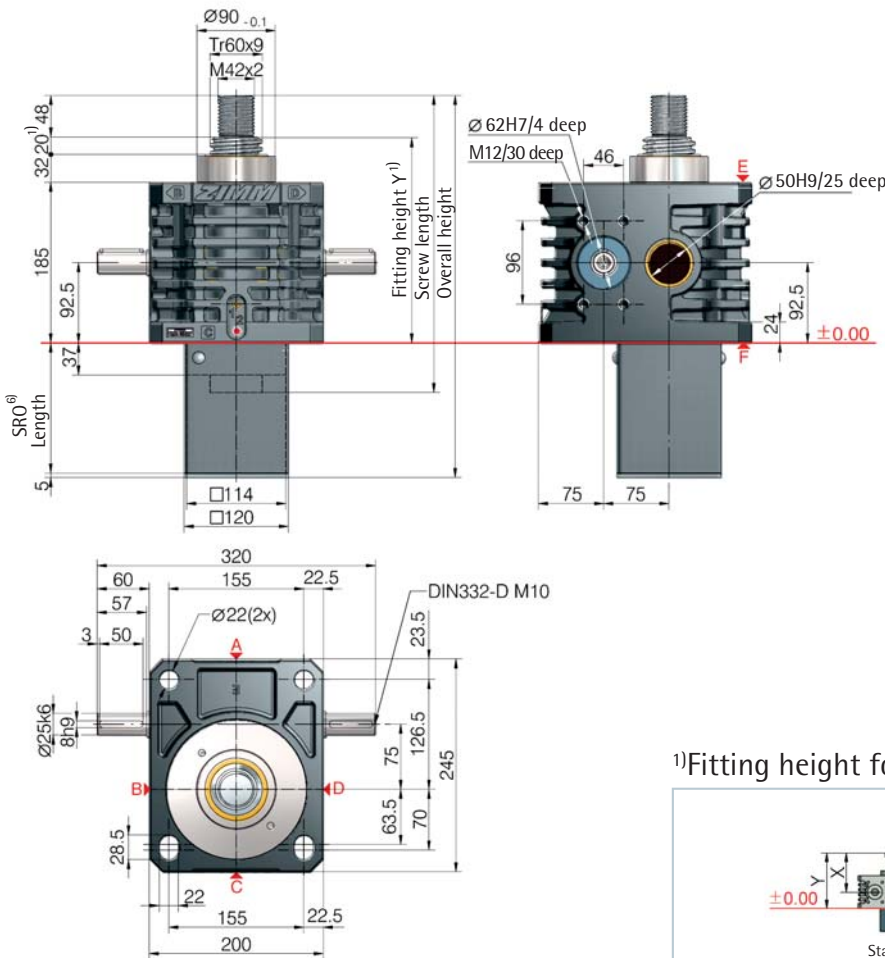
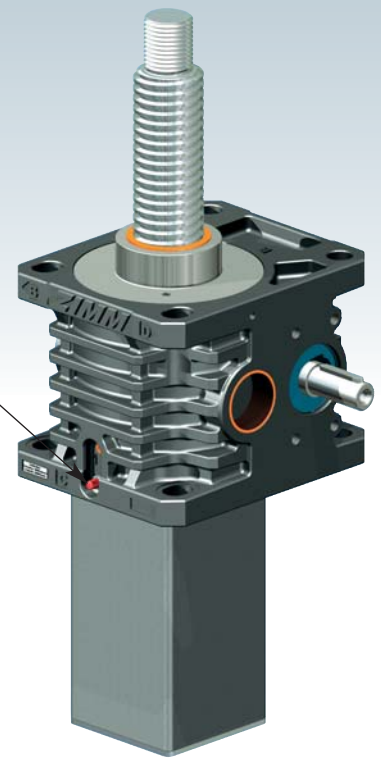

Opening for protective tube SRO square 135x135 or round Ø 175

1) Fitting height for 0-stroke, with Tr 60x9 screw

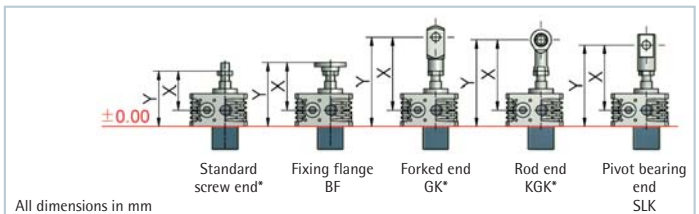

Bellocs FB	X/Y	X/Y	X/Y	X/Y	X/Y
without bellocs FB	145/237	195/287	313/405	305/397	300/392
Z-150-FB-350	198/290	223/315	366/458	358/450	328/420
Z-150-FB-600	220/312	245/337	388/480	380/472	350/442
Z-150-FB-1000	278/370	303/395	446/538	438/530	408/500
Z-150-FB-1500	328/420	353/445	496/588	488/580	458/550

\*with bellows fixing ring Z-150-FBR

6) Protective tube length SRO with Tr 60x9 screw

Without escape/rotation protection	Escape/rotation protection	Rotation protection, with limit switch set ES
87+stroke	117+stroke	149+stroke

Standard ratios

Type	Version	Speed	Standard screw <sup>2)</sup>	i	Stroke per drive shaft rotation <sup>5)</sup>
Z-150-SN	Translating	Normal	Tr 60x9	9:1	1.00 mm
Z-150-SL	screw	Low speed		36:1	0.25 mm
Z-150-RN	Rotating	Normal	Tr 60x9	9:1	1.00 mm
Z-150-RL	screw	Low speed		36:1	0.25 mm

Screw jack mounting



Duty cycle thermal limit, for S+R

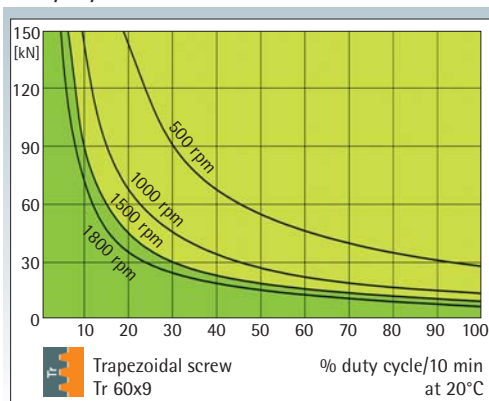

These curves are for guidance under standard industrial conditions (ambient temperature etc.) and correct maintenance (lubrication etc.). The max. input drive torques for optimum service life are at the right page - technical data (1500 rpm)

KGT: % duty cycle 2 times to 4 times higher

Trapezoidal screw

Tr



## Z-150-R rotating screw 150 kN

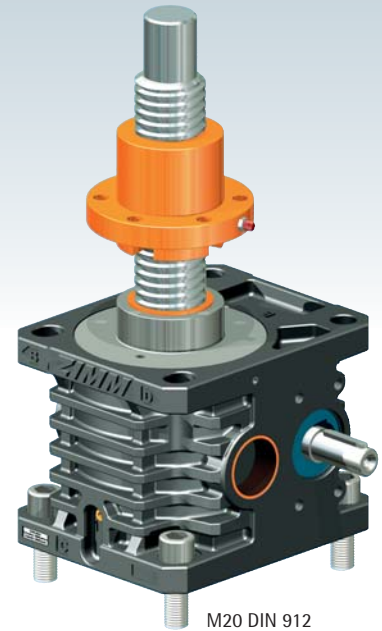
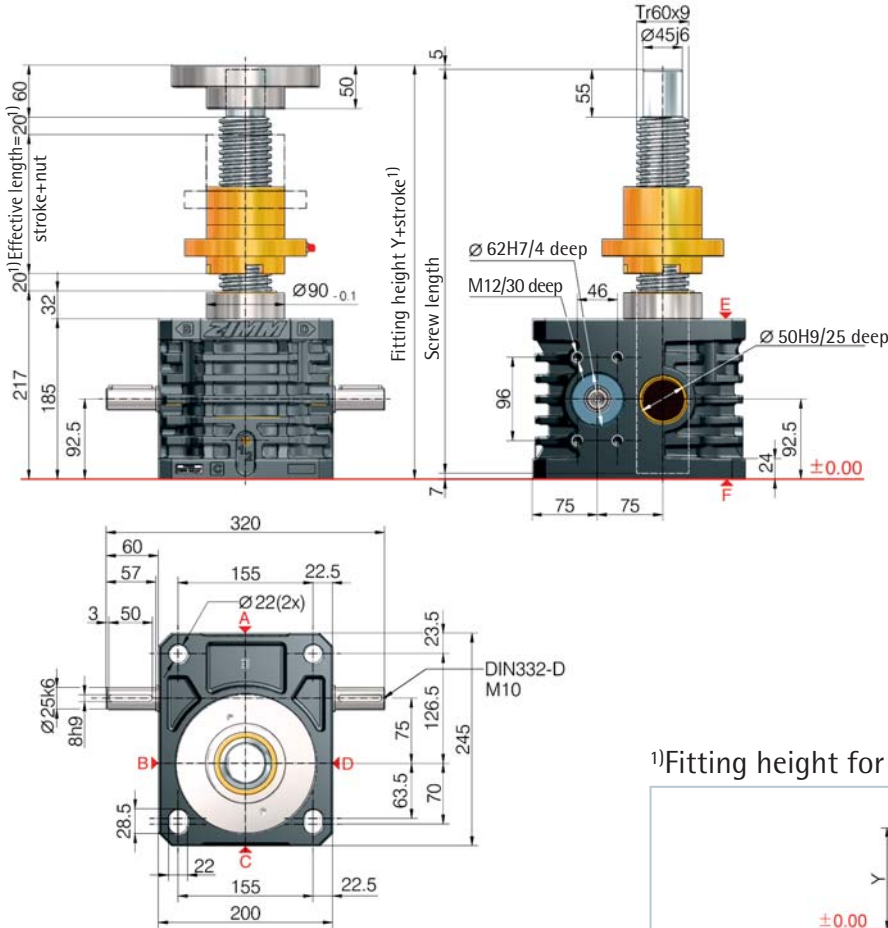

<sup>1)</sup>Fitting height for 0-stroke, with Tr 60x9 screw

All dimensions in mm	Duplex nut DM	Duplex nut DM with SIFA	Self-aligning nut PM
Bellocs FB	Y/A	Y/A	Y/A
without bellows FB	432/277	528/373	527/402
2x Z-150-FB-300	480/305	571/396	575/430
2x Z-150-FB-600	524/327	615/418	619/452
2x Z-150-FB-1000	640/385	731/476	735/510
2x Z-150-FB-1500	740/435	831/526	835/560

Detailed instructions for determining the length can be found in Section 8

# 150 kN

## Technical data series Z-150-S / Z-150-R

max. compressive/tensile force, static	- 150 kN (15 t)
max. compressive/tensile force, dynamic	- see duty cycle curves
Nominal speed	- 1500 rpm
max. drive shaft speed	- 1800 rpm
Screw size standard	- Tr 60x9 <sup>2)</sup>
Gear ratio	- 9:1 (N) / 36:1 (L)
Housing material	- GGG-50, corrosion-resistant
Worm shaft	- steel, case-hardened, ground
Weight of screw jack body	- 42 kg
Weight of screw/m	- 19 kg
Gearbox lubrication	- synthetic fluid grease
Screw lubrication	- grease lubrication
Gearbox operating temperature	- max. 60°C, higher on request
Moment of inertia	- N: 22.47 kg cm <sup>2</sup> / L: 7.96 kg cm <sup>2</sup>
Input torque (at 1500 rpm)	- max. 75.1 Nm (N) / max. 20.7 Nm (L)
Drive-through torque	- max. 540 Nm

Drive torque $M_G$ (Nm)	- $F$ (kN) $\times$ 0.75 <sup>3)</sup> + $M_L$ (N-normal)
Breakaway torque	- $F$ (kN) $\times$ 0.25 <sup>3)</sup> + $M_L$ (L-low speed)
Idling torque <sup>4)</sup> $M_L$ (Nm)	- Drive torque $M_G$ $\times$ 1.5
	- 1.90 (N-normal) / 1.20 (L-low speed)

Between gearbox and nut or nut and end of thread, provide for a safety distance of (minimum) 20 mm!

See Section 7 for the checklist.

## Important information

- 1) - extension if a bellows or spiral spring is fitted: see the table or Section 8
- 2) - Tr 60x9 is standard, also available: double-pitch, stainless steel, left-handed, increased screw Tr 80x16 (only for the R version)
- 3) - factor includes efficiency, ratio and 30% safety
- 4) - at 20°C, can be higher when new
- 5) - for a 9 mm screw pitch



Z-250-S translating screw 250 kN

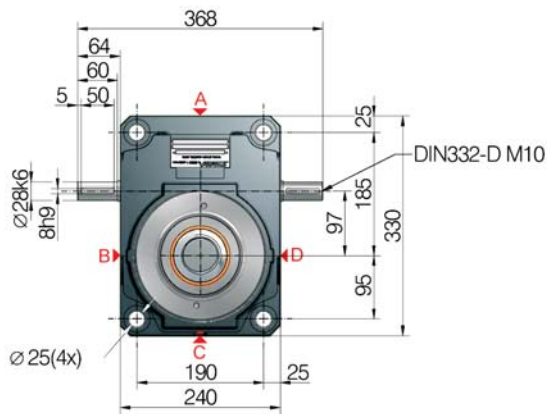
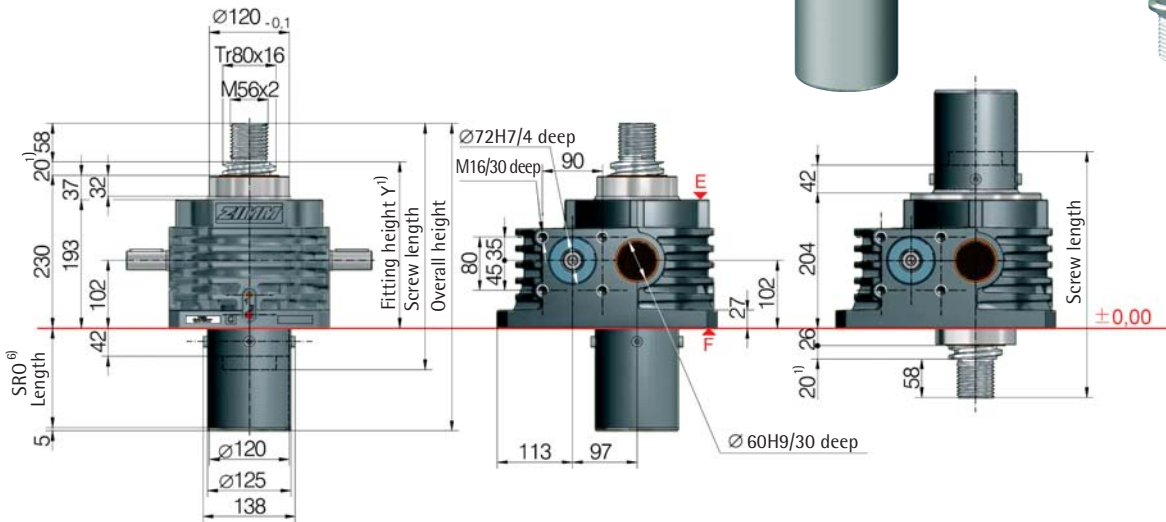
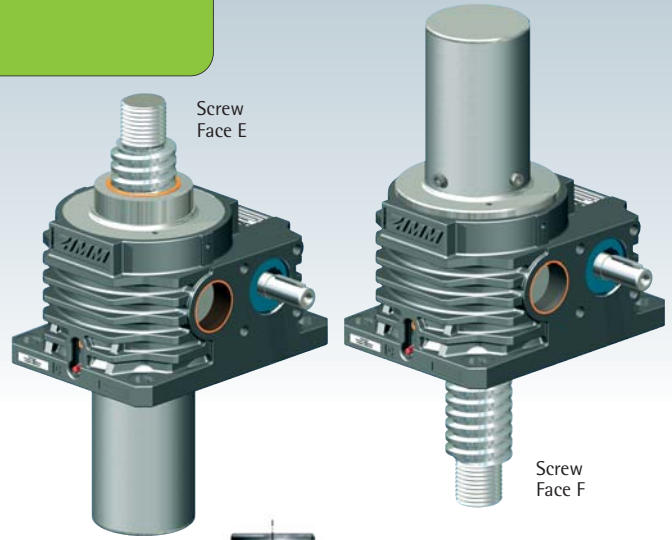

Opening for protective tube SRO

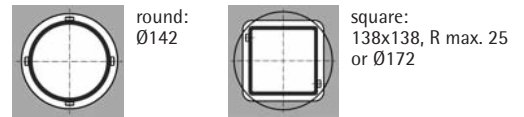

6) Protective tube length SRO with Tr 80x16 screw

only screw	with escape protection AS	with rotation protection VS	with VS and limit switch set ES
○ Ø125	○ Ø125	□ 120x120	□ 120x120
92+stroke	122+stroke	122+stroke	150+stroke

1) Fitting height for 0-stroke, with Tr 80x16 screw

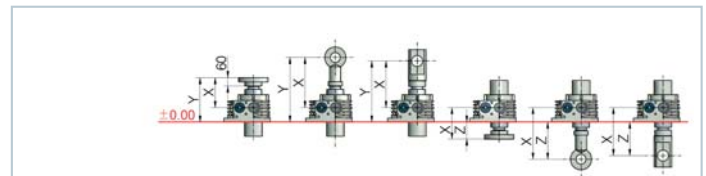

All dimensions in mm	BF	KGK*	SLK	BF	KGK*	SLK
Bellows FB	X/Y	X/Y	X/Y	X/Z	X/Z	X/Z
without bellows FB	208/310	348/450	328/430	208/106	348/246	328/226
Z-250-FB-390	276/378	441/543	396/498	276/174	441/339	396/294
Z-250-FB-600	258/360	423/525	378/480	258/156	423/321	378/276
Z-250-FB-1000	316/418	481/583	436/538	316/214	481/379	436/334
Z-250-FB-1500	366/468	531/633	486/588	366/264	531/429	486/384

\*with bellows fixing ring Z-250-FBR

Standard ratios

Type	Version	Speed	Standard screw <sup>2)</sup>	i	Stroke per drive shaft rotation <sup>5)</sup>
Z-250-SN	Translating	Normal	Tr 80x16	10.66:1	1.5 mm
Z-250-SL	screw	Low speed		32:1	0.5 mm
Z-250-RN	Rotating	Normal	Tr 80x16	10.66:1	1.5 mm
Z-250-RL	screw	Low speed		32:1	0.5 mm

Screw jack mounting



Duty cycle thermal limit, for S+R

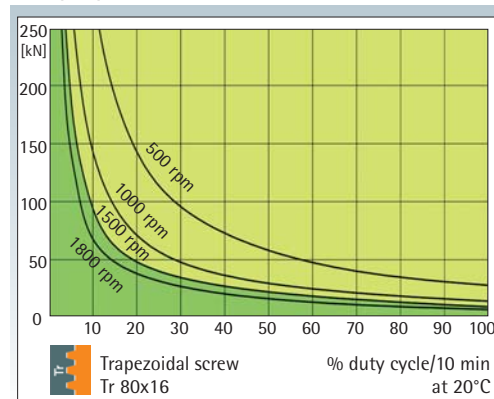

These curves are for guidance under standard industrial conditions (ambient temperature etc.) and correct maintenance (lubrication etc.). The max. input drive torques for optimum service life are at the right page - technical data (1500 rpm)

KGK: % duty cycle 2 times to 4 times higher



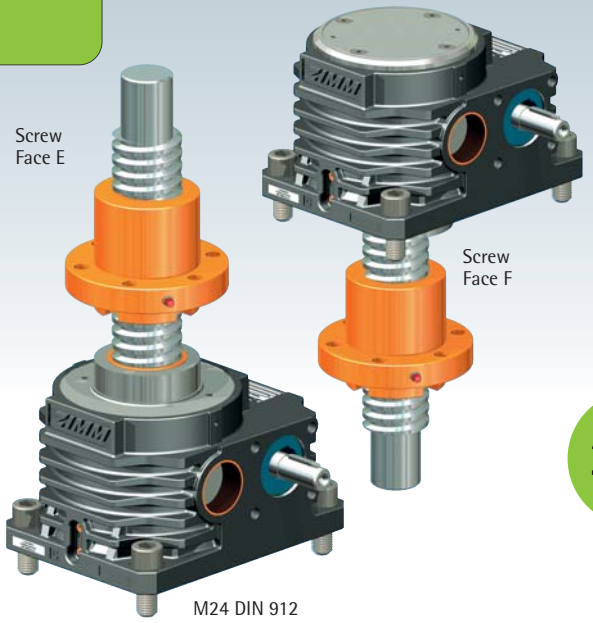

Z-250-R rotating screw 250 kN

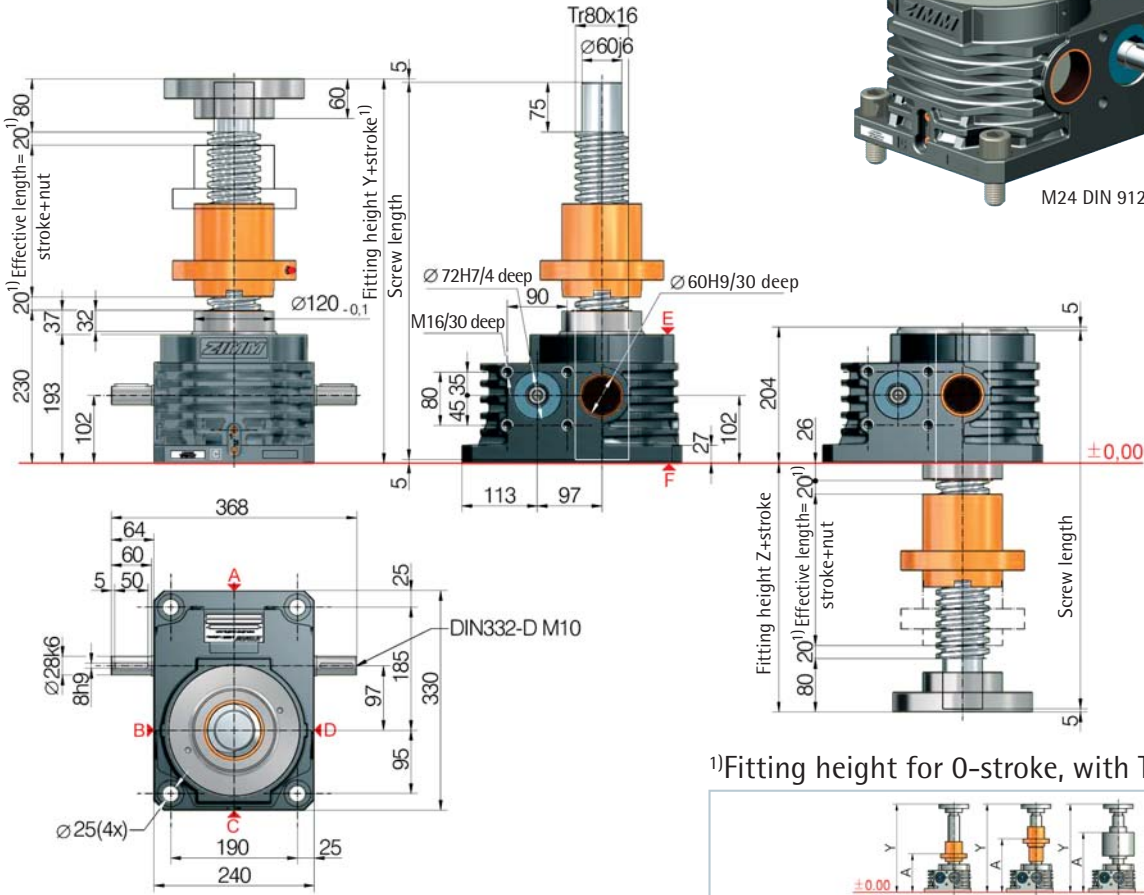

M24 DIN 912

1) Fitting height for 0-stroke, with Tr 80x16 screw

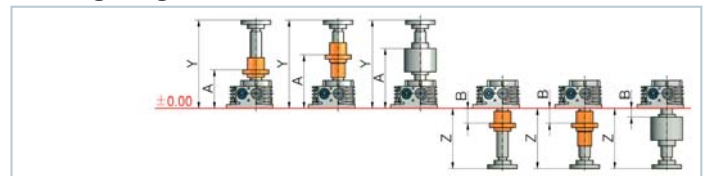

All dimensions in mm	DM	DM with SIFA	PM	DM	DM with SIFA	DM
Bellows FB	Y/A	Y/A	Y/A	Z/B	Z/B	Z/B
without bellows FB	490/305	600/415	574/434	286/131	396/131	370/86
2x Z-250-FB-390	608/373	712/477	692/502	404/199	514/199	488/154
2x Z-250-FB-600	572/355	676/459	656/484	368/181	478/181	452/136
2x Z-250-FB-1000	688/413	792/517	772/542	484/239	594/239	568/194
2x Z-250-FB-1500	788/463	892/567	872/592	584/289	694/289	668/244

Detailed instructions for determining the length can be found in Section 8

# 250 kN

Technical data series Z-250-S / Z-250-R

- max. compressive/tensile force, static - 250 kN (25 t)
- max. compressive/tensile force, dynamic - see duty cycle curves
- Nominal speed - 1500 rpm
- max. drive shaft speed - 1800 rpm
- Screw size standard - Tr 80x16<sup>2)</sup>
- Gear ratio - 10.66:1 (N) / 32:1 (L)
- Housing material - GGG-50, corrosion-resistant
- Worm shaft - steel, case-hardened, ground
- Weight of screw jack body - 59 kg
- Weight of screw/m - 32 kg
- Gearbox lubrication - synthetic gear oil
- Screw lubrication - grease lubrication
- Gearbox operating temperature - max. 60°C, higher on request
- Moment of inertia - N: 53.8 kg cm<sup>2</sup> / L: 22.0 kg cm<sup>2</sup>
- Input torque (at 1500 rpm) - max. 152 Nm (N) / max. 41.4 Nm (L)
- Drive-through torque - max. 770 Nm

- Drive torque  $M_G$  (Nm) -  $F$  (kN)  $\times$  0.94<sup>3)5)</sup> +  $M_L$  (N-normal)
- $F$  (kN)  $\times$  0.37<sup>3)5)</sup> +  $M_L$  (L-low speed)
- Breakaway torque - Drive torque  $M_G$   $\times$  1.5
- Idling torque<sup>4)</sup>  $M_L$  (Nm) - 2.64 (N-normal) / 1.94 (L-low speed)

Between gearbox and nut or nut and end of thread, provide for a safety distance of (minimum) 20 mm!  
See Section 7 for the checklist.

Important information

- 1) - extension if a bellows or spiral spring is fitted: see the table or Section 8
- 2) - Tr 80x16 is standard, also available: double-pitch, stainless steel, left-handed, increased screw Tr 100x16 (only for the R version)
- 3) - factor includes efficiency, ratio and 30% safety
- 4) - at 20°C, can be higher when new
- 5) - for a 16 mm screw pitch



Z-350-S translating screw 350 kN

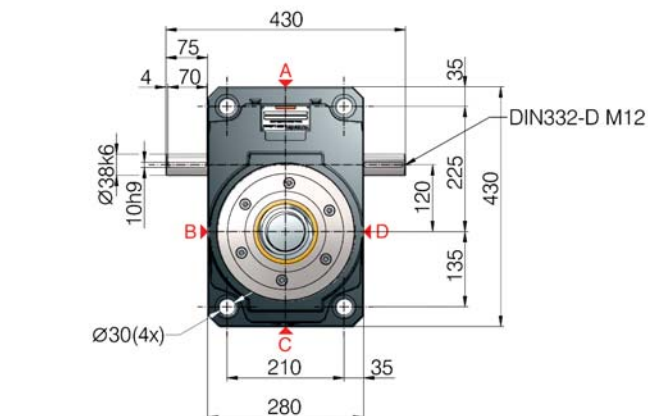
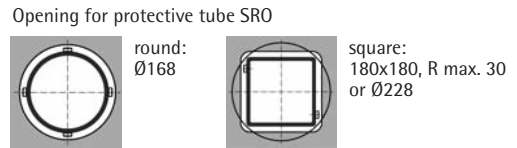
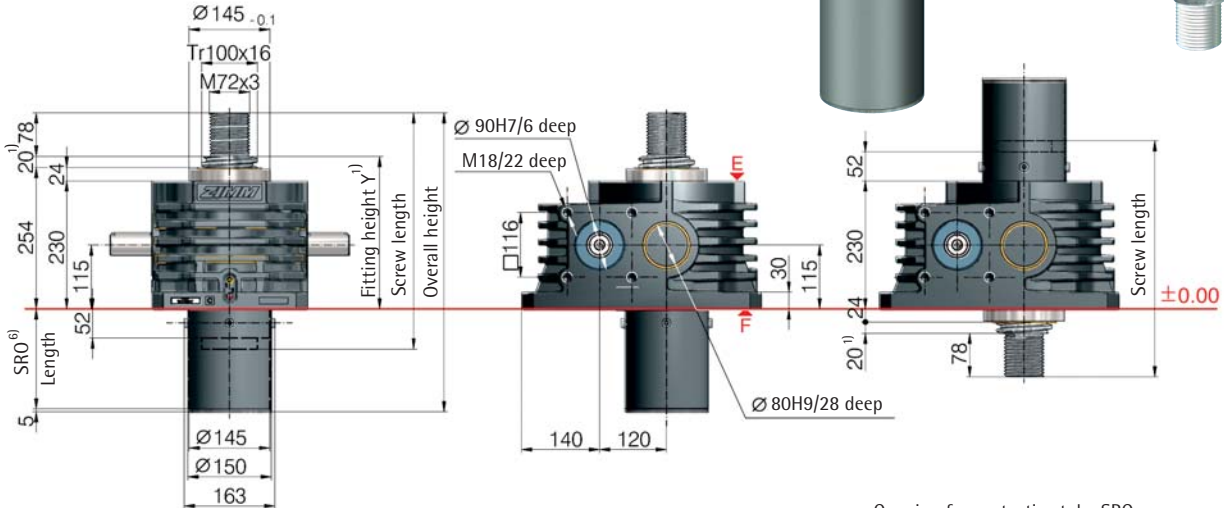
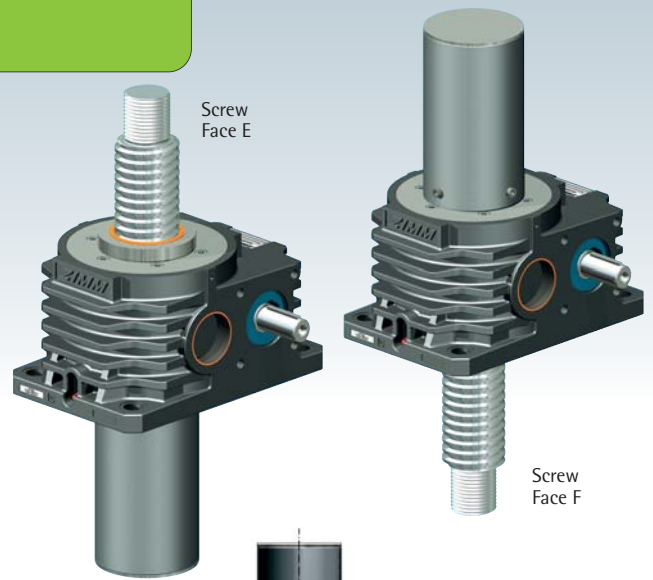

6) Protective tube length SRO with Tr 100x16 screw

only screw	with escape protection AS	with rotation protection VS	with VS and limit switch set ES
$\varnothing 150$	$\varnothing 150$	$\square 160 \times 160$	$\square 160 \times 160$
107+stroke	142+stroke	142+stroke	166+stroke

1) Fitting height for 0-stroke, with Tr 100x16 screw

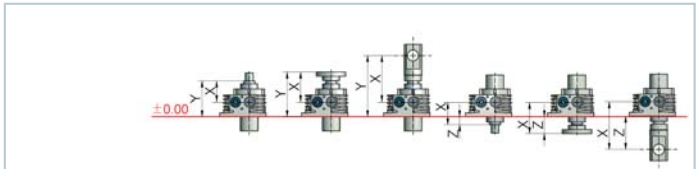

All dimensions in mm

	BF		SLK		BF		SLK	
Bellocs FB	X/Y	X/Y	X/Y	X/Y	X/Z	X/Z	X/Z	X/Z
without bellocs FB	159/274	239/354	354/469	159/44	239/124	354/239		
Z-350-FB-600	262/377	317/432	432/547	262/147	317/202	432/317		
Z-350-FB-900	270/385	325/440	440/555	270/155	325/210	440/325		
Z-350-FB-1500	342/457	397/512	512/627	342/227	397/282	512/397		

Standard ratios

Type	Version	Speed	Standard screw <sup>2)</sup>	i	Stroke per drive shaft rotation <sup>5)</sup>
Z-350-SN	Translating	Normal	Tr 100x16	10.66:1	1.5 mm
Z-350-SL	screw	Low speed		32:1	0.5 mm
Z-350-RN	Rotating	Normal	Tr 100x16	10.66:1	1.5 mm
Z-350-RL	screw	Low speed		32:1	0.5 mm

Screw jack mounting

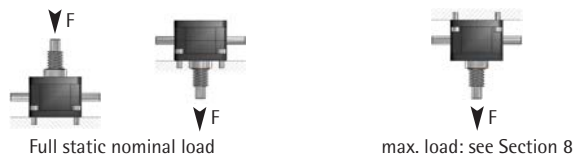

Duty cycle thermal limit, for S+R

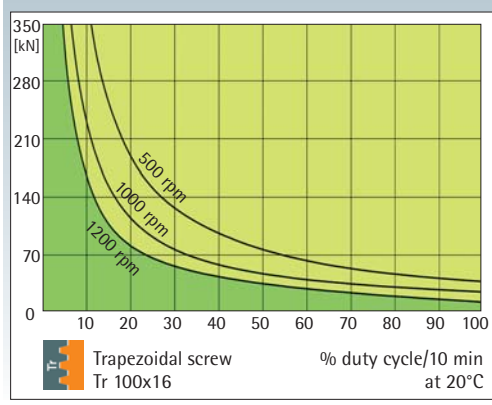

These curves are for guidance under standard industrial conditions (ambient temperature etc.) and correct maintenance (lubrication etc.). The max. input drive torques for optimum service life are at the right page - technical data (1000 rpm)

KGT: % duty cycle 2 times to 4 times higher



Z-350-R rotating screw 350 kN

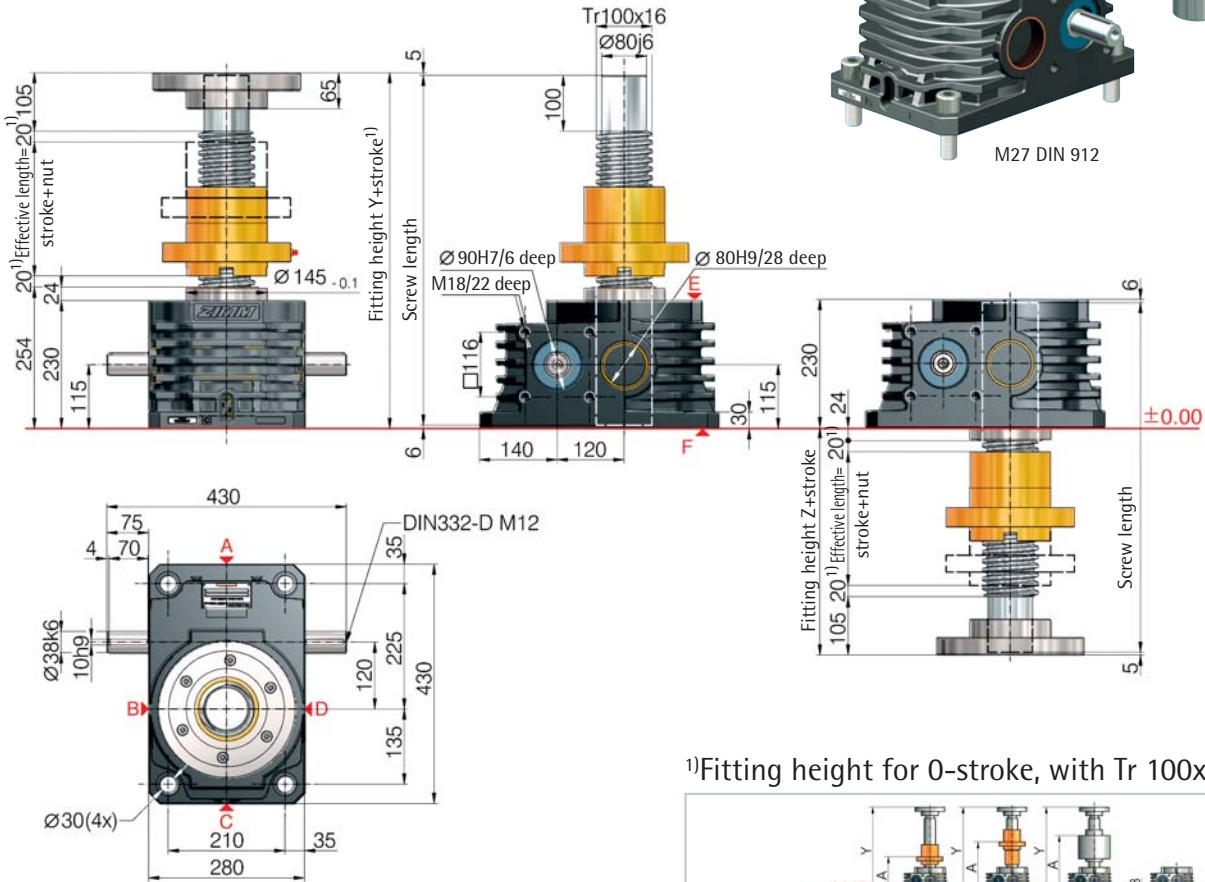
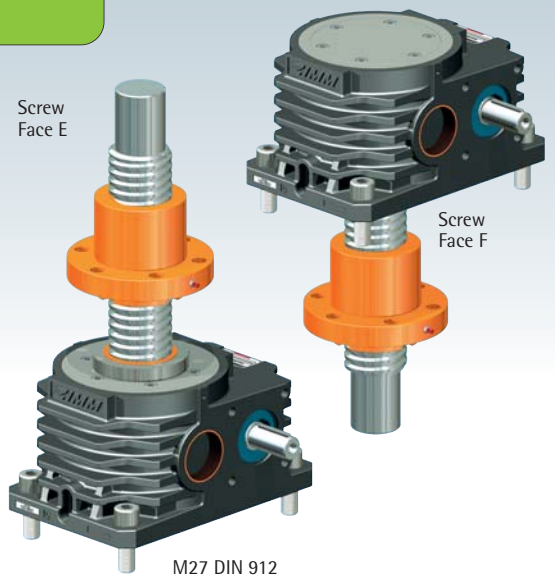

1) Fitting height for 0-stroke, with Tr 100x16 screw

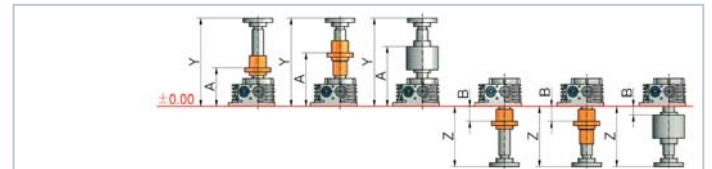

All dimensions in mm	DM	DM with SIFA	PM	DM	DM with SIFA	DM
<b>Bellows FB</b>	Y/A	Y/A	Y/A	Z/B	Z/B	Z/B
without bellows FB	559/334	669/444	674/509	329/144	439/144	444/84
2x Z-350-FB-600	677/412	781/516	792/587	447/222	557/222	562/162
2x Z-350-FB-900	693/420	797/524	808/595	463/230	573/230	578/170
2x Z-350-FB-1500	837/492	941/596	952/667	607/302	717/302	722/242

Detailed instructions for determining the length can be found in Section 8

# 350 kN

Technical data series Z-350-S / Z-350-R

- max. compressive/tensile force, static - 350 kN (35 t)
- max. compressive/tensile force, dynamic - see duty cycle curves
- Nominal speed - 1000 rpm
- max. drive shaft speed - 1200 rpm
- Screw size standard - Tr 100x16<sup>2)</sup>
- Gear ratio - 10.66:1 (N) / 32:1 (L)
- Housing material - GGG-50, corrosion-resistant
- Worm shaft - steel, case-hardened, ground
- Weight of screw jack body - 112 kg
- Weight of screw/m - 52 kg
- Gearbox lubrication - synthetic gear oil
- Screw lubrication - grease lubrication
- Gearbox operating temperature - max. 60°C, higher on request
- Moment of inertia - N: 148.9 kg cm<sup>2</sup> / L: 66.1 kg cm<sup>2</sup>
- Input torque (at 1000 rpm) - max. 265 Nm (N) / max. 100 Nm (L)
- Drive-through torque - max. 1800 Nm

- Drive torque  $M_G$  (Nm) -  $F$  (kN)  $\times$  1.09<sup>3)5)</sup> +  $M_L$  (N-normal)
- $F$  (kN)  $\times$  0.42<sup>3)5)</sup> +  $M_L$  (L-low speed)
- Breakaway torque - Drive torque  $M_G$   $\times$  1.5
- Idling torque<sup>4)</sup>  $M_L$  (Nm) - 3.24 (N-normal) / 2.20 (L-low speed)

Between gearbox and nut or nut and end of thread, provide for a safety distance of (minimum) 20 mm!  
See Section 7 for the checklist.

**Important information**

- 1) - extension if a bellows or spiral spring is fitted: see the table or Section 8
- 2) - Tr 100x16 is standard, also available: double-pitch, stainless steel, left-handed, increased screw Tr 120x16 (only for the R version)
- 3) - factor includes efficiency, ratio and 30% safety
- 4) - at 20°C, can be higher when new
- 5) - for a 16 mm screw pitch



Z-500-S translating screw 500 kN

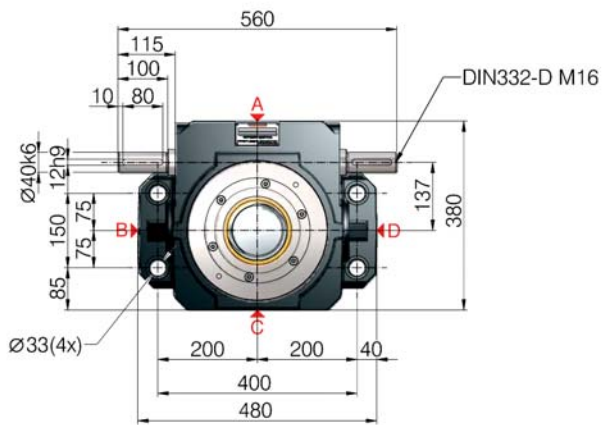
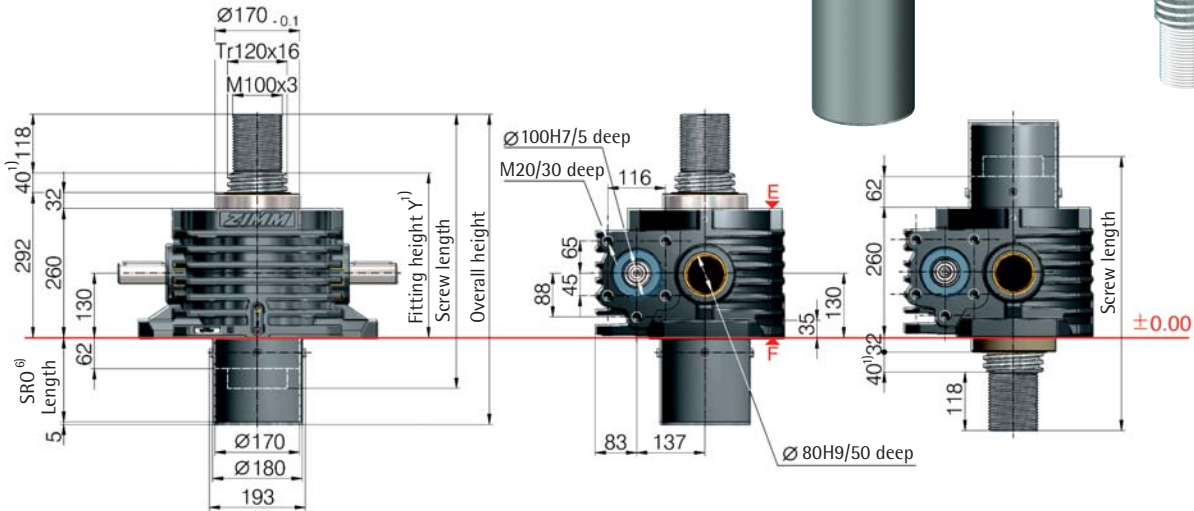
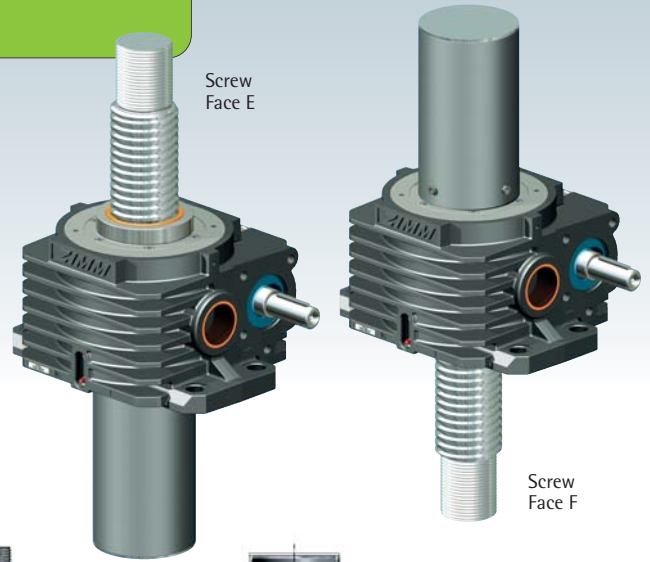

Opening for protective tube SRO

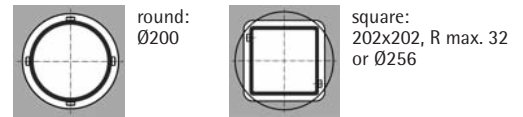

6) Protective tube length SRO with Tr 120x16 screw

only screw	with escape protection AS	with rotation protection VS	with VS and limit switch set ES
○ Ø180	○ Ø180	□ 180x180	□ 180x180
157+stroke	197+stroke	197+stroke	197+stroke

1) Fitting height for 0-stroke, with Tr 120x16 screw

All dimensions in mm	BF		SLK	BF		SLK
	X/Y	X/Y	X/Y	X/Z	X/Z	X/Z
without bellows FB	202/332	322/452	447/577	202/72	322/192	447/317

Standard ratios

Type	Version	Speed	Standard screw <sup>2)</sup>	i	Stroke per drive shaft rotation <sup>5)</sup>
Z-500-SN	Translating	Normal	Tr 120x16	10.66:1	1.5 mm
Z-500-SL	screw	Low speed		32:1	0.5 mm
Z-500-RN	Rotating	Normal	Tr 120x16	10.66:1	1.5 mm
Z-500-RL	screw	Low speed		32:1	0.5 mm

Screw jack mounting



Duty cycle thermal limit, for S+R

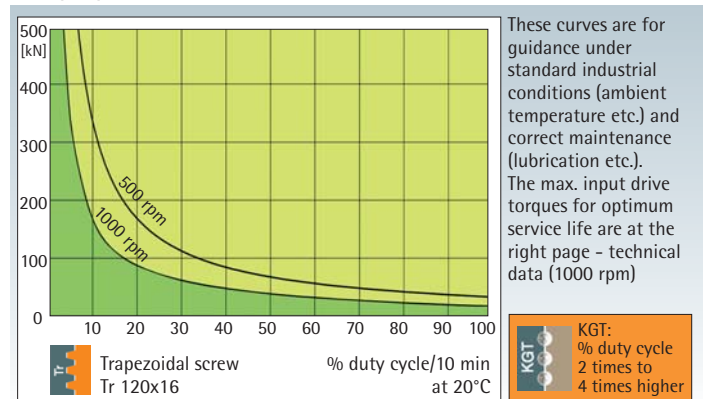



Z-500-R rotating screw 500 kN

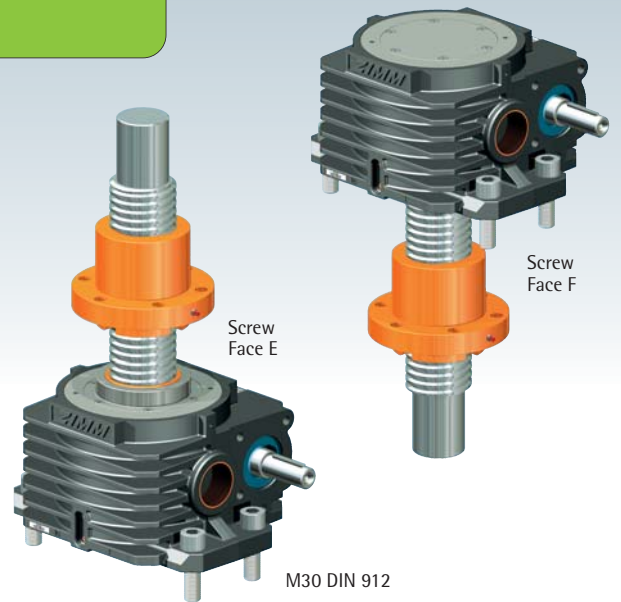
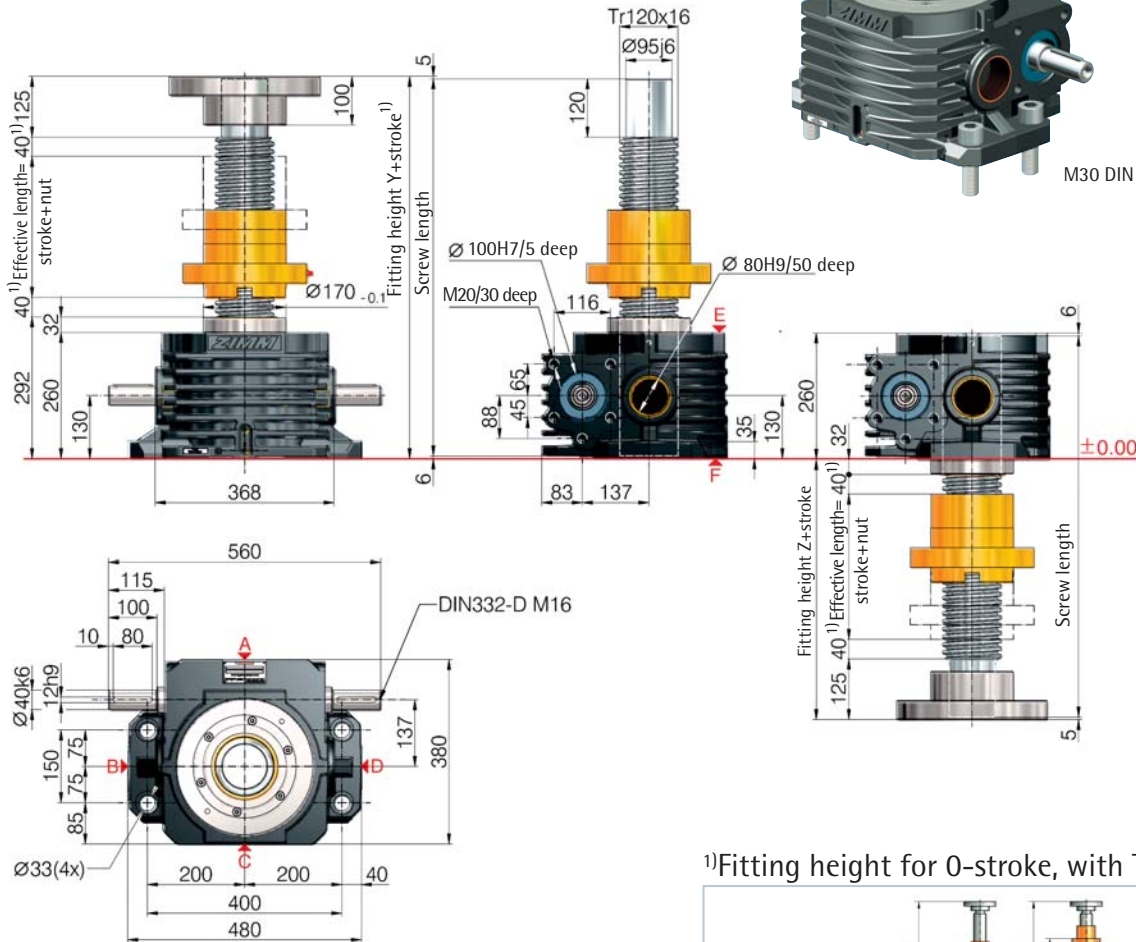

500 kN

1) Fitting height for 0-stroke, with Tr 120x16 screw

All dimensions in mm	DM	DM with SIFA	DM	DM with SIFA
	Y/A	Y/A	Z/B	Z/B
without bellows FB	677/402	800/525	417/182	540/182

Detailed instructions for determining the length can be found in Section 8

Technical data series Z-500-S / Z-500-R

- max. compressive/tensile force, static - 500 kN (50 t)
- max. compressive/tensile force, dynamic - see duty cycle curves
- Nominal speed - 1000 rpm
- max. drive shaft speed - 1000 rpm
- Screw size standard - Tr 120x16<sup>2)</sup>
- Gear ratio - 10.66:1 (N) / 32:1 (L)
- Housing material - GGG-50, corrosion-resistant
- Worm shaft - steel, case-hardened, ground
- Weight of screw jack body - 168 kg
- Weight of screw/m - 77 kg
- Gearbox lubrication - synthetic gear oil
- Screw lubrication - grease lubrication
- Gearbox operating temperature - max. 60°C, higher on request
- Moment of inertia - N: 310.2 kg cm<sup>2</sup> / L: 127.8 kg cm<sup>2</sup>
- Input torque (at 1000 rpm) - max. 408 Nm (N) / max. 170 Nm (L)
- Drive-through torque - max. 1940 Nm

- Drive torque M<sub>G</sub> (Nm) - F (kN) x 1.24<sup>3)5)</sup> + M<sub>L</sub> (N-normal)  
- F (kN) x 0.50<sup>3)5)</sup> + M<sub>L</sub> (L-low speed)
- Breakaway torque - Drive torque M<sub>G</sub> x 1.5
- Idling torque<sup>4)</sup> M<sub>L</sub> (Nm) - 3.96 (N-normal) / 2.84 (L-low speed)

Between gearbox and nut or nut and end of thread, provide for a safety distance of (minimum) 40 mm!  
See Section 7 for the checklist.

Important information

- 1) - extension if a bellows or spiral spring is fitted: see Section 8
- 2) - Tr 120x16 is standard, also available: double-pitch, stainless steel, left-handed, increased screw Tr 140x20 (only for the R version)
- 3) - factor includes efficiency, ratio and 30% safety
- 4) - at 20°C, can be higher when new
- 5) - for a 16 mm screw pitch



Z-750-S translating screw 750 kN

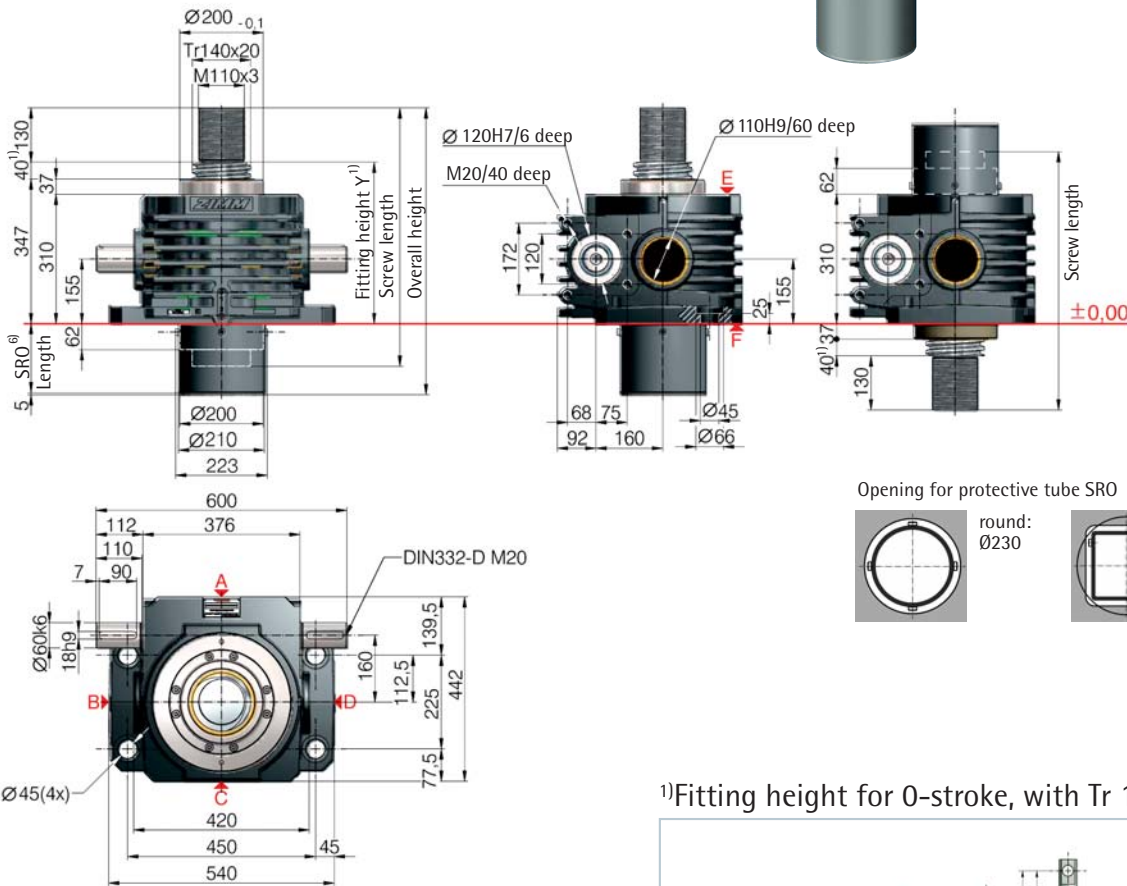
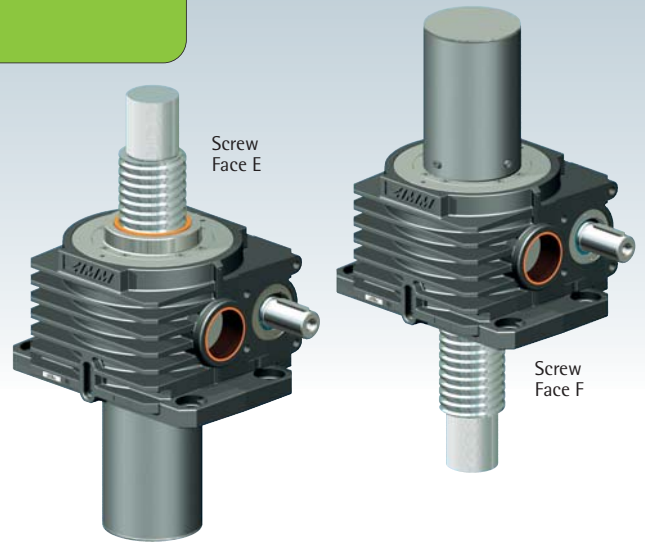

Opening for protective tube SRO

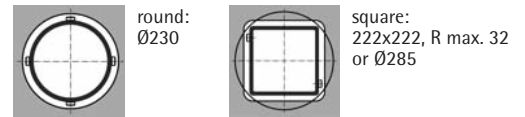

6) Protective tube length SRO with Tr 140x20 screw

only screw	with escape protection AS	with rotation protection VS	with VS and limit switch set ES
○ Ø210	○ Ø210	□ 200x200	□ 200x200
157+stroke	197+stroke	197+stroke	205+stroke

1) Fitting height for 0-stroke, with Tr 140x20 screw

All dimensions in mm	BF		SLK	BF		SLK
	X/Y	X/Y	X/Y	X/Z	X/Z	X/Z
without bellows FB	232/387	364/519	on request	232/77	364/209	on request

Standard ratios

Type	Version	Speed	Standard screw <sup>2)</sup>	i	Stroke per drive shaft rotation <sup>5)</sup>
Z-750-SN	Translating	Normal	Tr 140x20	13.33:1	1.5 mm
Z-750-SL	screw	Low speed		40:1	0.5 mm
Z-750-RN	Rotating	Normal	Tr 140x20	13.33:1	1.5 mm
Z-750-RL	screw	Low speed		40:1	0.5 mm

Screw jack mounting



Duty cycle thermal limit, for S+R

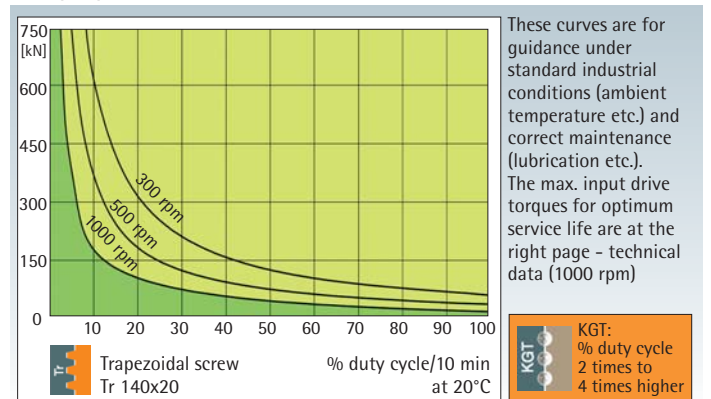

Trapezoidal screw

Tr



## Z-750-R rotating screw 750 kN

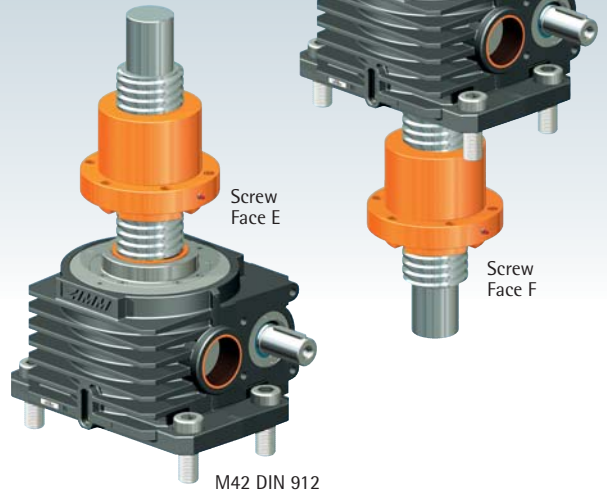
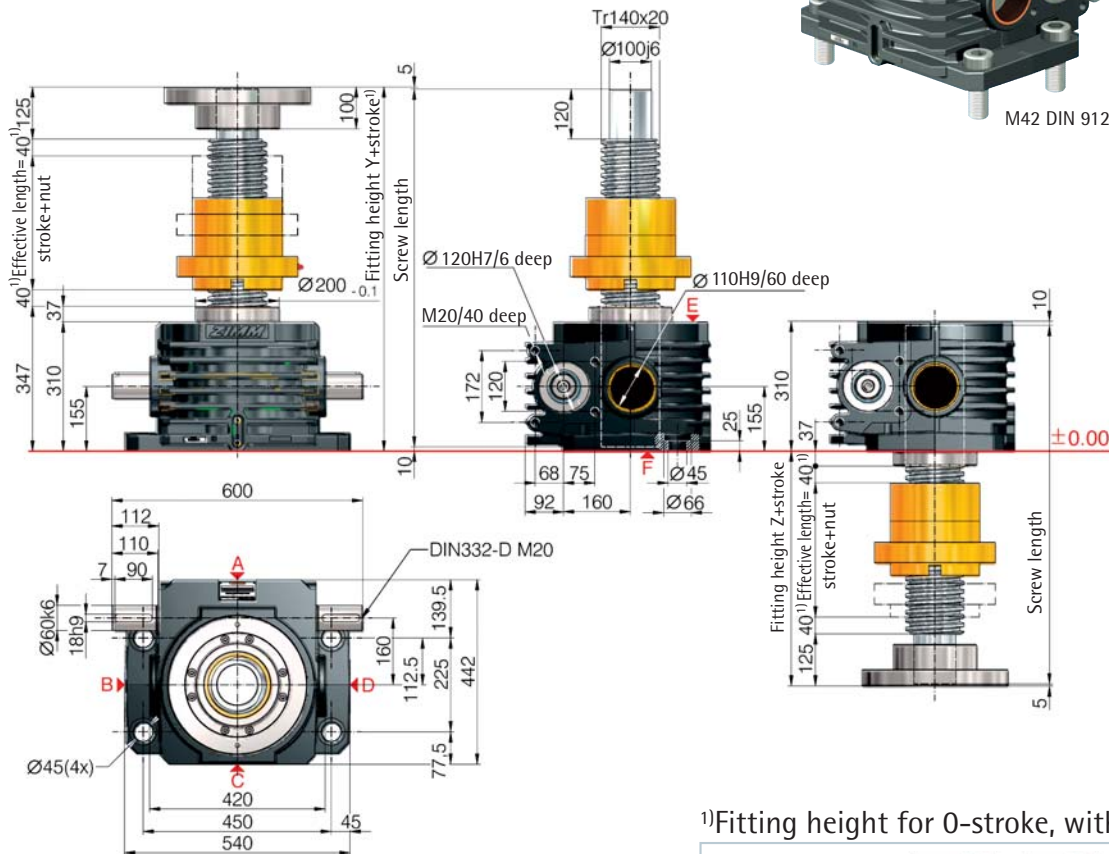

1) Fitting height for 0-stroke, with Tr 140x20 screw

All dimensions in mm	DM	DM with SIFA	DM	DM with SIFA
	Y/A	Y/A	Z/B	Z/B
without bellows FB	772/467	917/612	462/217	607/217

Detailed instructions for determining the length can be found in Section 8

# 750 kN

## Technical data series Z-750-S / Z-750-R

max. compressive/tensile force, static	- 750 kN (75 t)
max. compressive/tensile force, dynamic	- see duty cycle curves
Nominal speed	- 1000 rpm
max. drive shaft speed	- 1000 rpm
Screw size standard	- Tr 140x20 <sup>2)</sup>
Gear ratio	- 13.33:1 (N) / 40:1 (L)
Housing material	- GGG-50, corrosion-resistant
Worm shaft	- steel, case-hardened, ground
Weight of screw jack body	- 262 kg
Weight of screw/m	- 104 kg
Gearbox lubrication	- synthetic gear oil
Screw lubrication	- grease lubrication
Gearbox operating temperature	- max. 60°C, higher on request
Moment of inertia	- N: 518.1 kg cm <sup>2</sup> / L: 256.1 kg cm <sup>2</sup>
Input torque (at 1000 rpm)	- max. 480 Nm (N) / max. 210 Nm (L)
Drive-through torque	- max. 4570 Nm

Drive torque $M_G$ (Nm)	- $F$ (kN) $\times$ 1.22 <sup>3)5)</sup> + $M_L$ (N-normal) - $F$ (kN) $\times$ 0.54 <sup>3)5)</sup> + $M_L$ (L-low speed)
Breakaway torque	- Drive torque $M_G$ $\times$ 1.5
Idling torque <sup>4)</sup> $M_L$ (Nm)	- 7.28 (N-normal) / 4.42 (L-low speed)

Between gearbox and nut or nut and end of thread, provide for a safety distance of (minimum) 40 mm!  
See Section 7 for the checklist.

## Important information

- 1) - extension if a bellows or spiral spring is fitted: see Section 8
- 2) - Tr 140x20 is standard, also available: double-pitch, stainless steel, left-handed, increased screw Tr 160x20 (only for the R version)
- 3) - factor includes efficiency, ratio and 30% safety
- 4) - at 20°C, can be higher when new
- 5) - for a 20 mm screw pitch

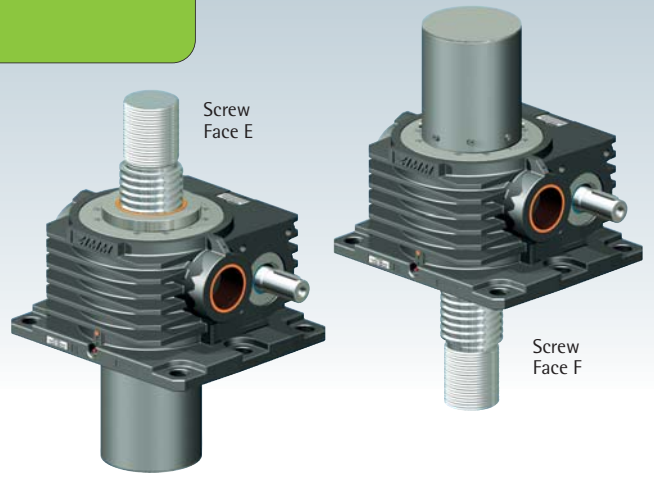

Z-1000-S translating screw 1,000 kN

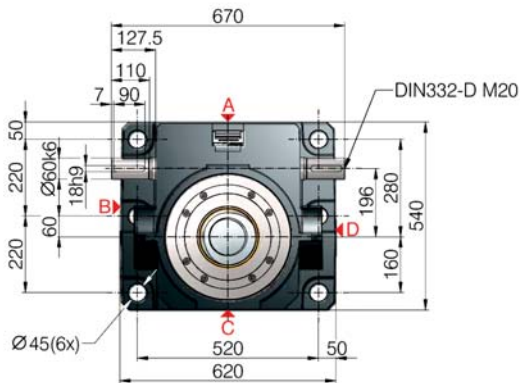
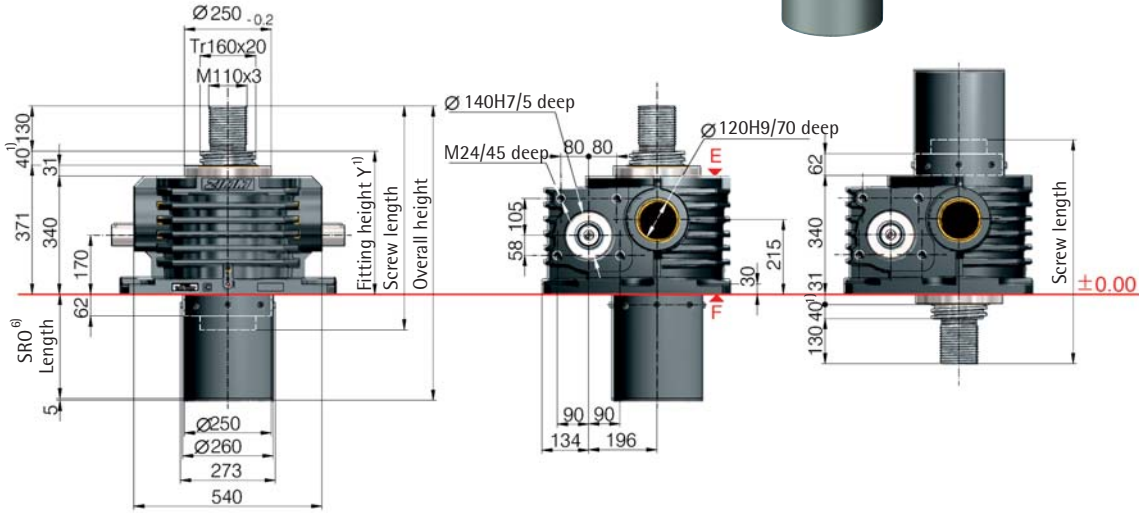

Opening for protective tube SRO

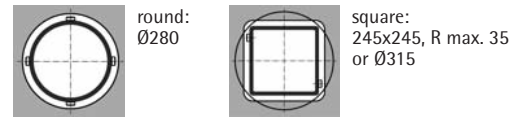

6) Protective tube length SRO with Tr 160x20 screw

only screw	with escape protection AS	with rotation protection VS	with VS and limit switch set ES
○ Ø260	○ Ø260	□ 220x220	□ 220x220
157+stroke	197+stroke	197+stroke	205+stroke

1) Fitting height for 0-stroke, with Tr 160x20 screw

All dimensions in mm	BF		SLK	BF		SLK
	X/Y	X/Y	X/Y	X/Z	X/Z	X/Z
without bellows FB	196/411	328/543	on request	196/181	328/313	on request

Standard ratios

Type	Version	Speed	Standard screw <sup>2)</sup>	i	Stroke per drive shaft rotation <sup>5)</sup>
Z-1000-SN	Translating screw	Normal	Tr 160x20	13.33:1	1.5 mm
Z-1000-SL		Low speed		40:1	0.5 mm
Z-1000-RN	Rotating screw	Normal	Tr 160x20	13.33:1	1.5 mm
Z-1000-RL		Low speed		40:1	0.5 mm

Screw jack mounting



Duty cycle thermal limit, for S+R

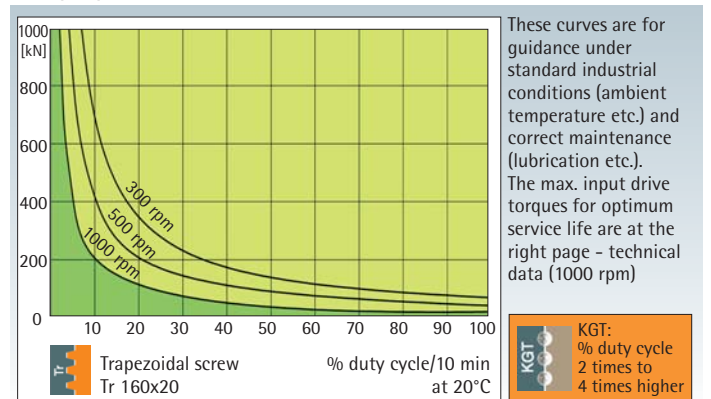





Z-1000-R rotating screw 1,000 kN

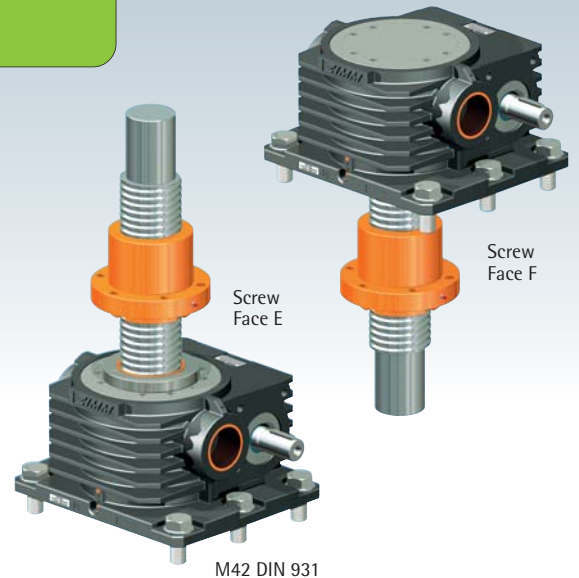
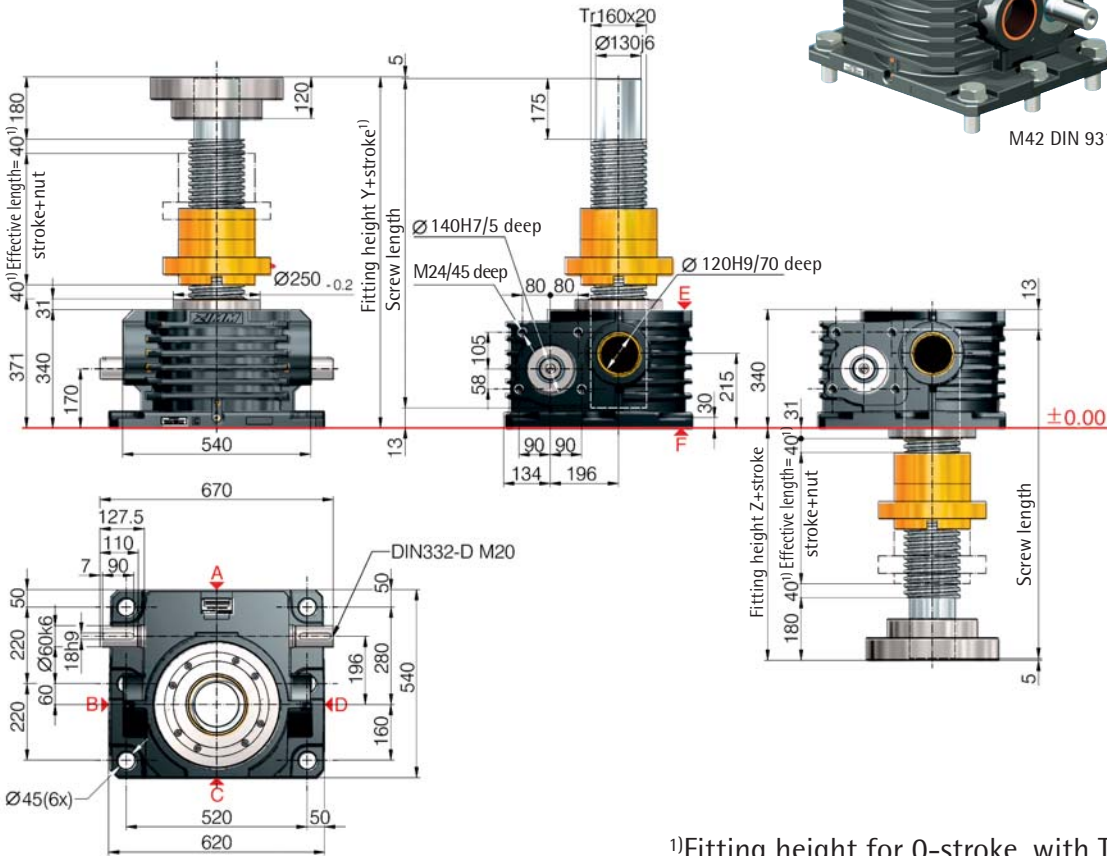

M42 DIN 931

1) Fitting height for 0-stroke, with Tr 160x20 screw

All dimensions in mm	DM	DM with SIFA	DM	DM with SIFA
	Y/A	Y/A	Z/B	Z/B
without bellows FB	951/521	1131/701	611/281	791/281

Detailed instructions for determining the length can be found in Section 8

**1000** kN

Technical data series Z-1000-S / Z-1000-R

- max. compressive/tensile force, static - 1000 kN (100 t)
- max. compressive/tensile force, dynamic - see duty cycle curves
- Nominal speed - 1000 rpm
- max. drive shaft speed - 1000 rpm
- Screw size standard - Tr 160x20<sup>2)</sup>
- Gear ratio - 13.33:1 (N) / 40:1 (L)
- Housing material - GGG-50, corrosion-resistant
- Worm shaft - steel, case-hardened, ground
- Weight of screw jack body - 408 kg
- Weight of screw/m - 139 kg
- Gearbox lubrication - synthetic gear oil
- Screw lubrication - grease lubrication
- Gearbox operating temperature - max. 60°C, higher on request
- Moment of inertia - N: 1058.2 kg cm<sup>2</sup> / L: 459.2 kg cm<sup>2</sup>
- Input torque (at 1000 rpm) - max. 680 Nm (N) / max. 450 Nm (L)
- Drive-through torque - max. 4570 Nm

- Drive torque  $M_G$  (Nm) -  $F$  (kN)  $\times$  1.32<sup>3)5)</sup> +  $M_L$  (N-normal)
- Breakaway torque -  $F$  (kN)  $\times$  0.51<sup>3)5)</sup> +  $M_L$  (L-low speed)
- Idling torque<sup>4)</sup>  $M_L$  (Nm) - Drive torque  $M_G$   $\times$  1.5
- 9.70 (N-normal) / 5.90 (L-low speed)

Between gearbox and nut or nut and end of thread, provide for a safety distance of (minimum) 40 mm!  
See Section 7 for the checklist.

Important information

- 1) - extension if a bellows or spiral spring is fitted: see Section 8
- 2) - Tr 160x20 is standard, also available: double-pitch, stainless steel, left-handed, increased screw Tr 190x24 (only for the R version)
- 3) - factor includes efficiency, ratio and 30% safety
- 4) - at 20°C, can be higher when new
- 5) - for a 20 mm screw pitch

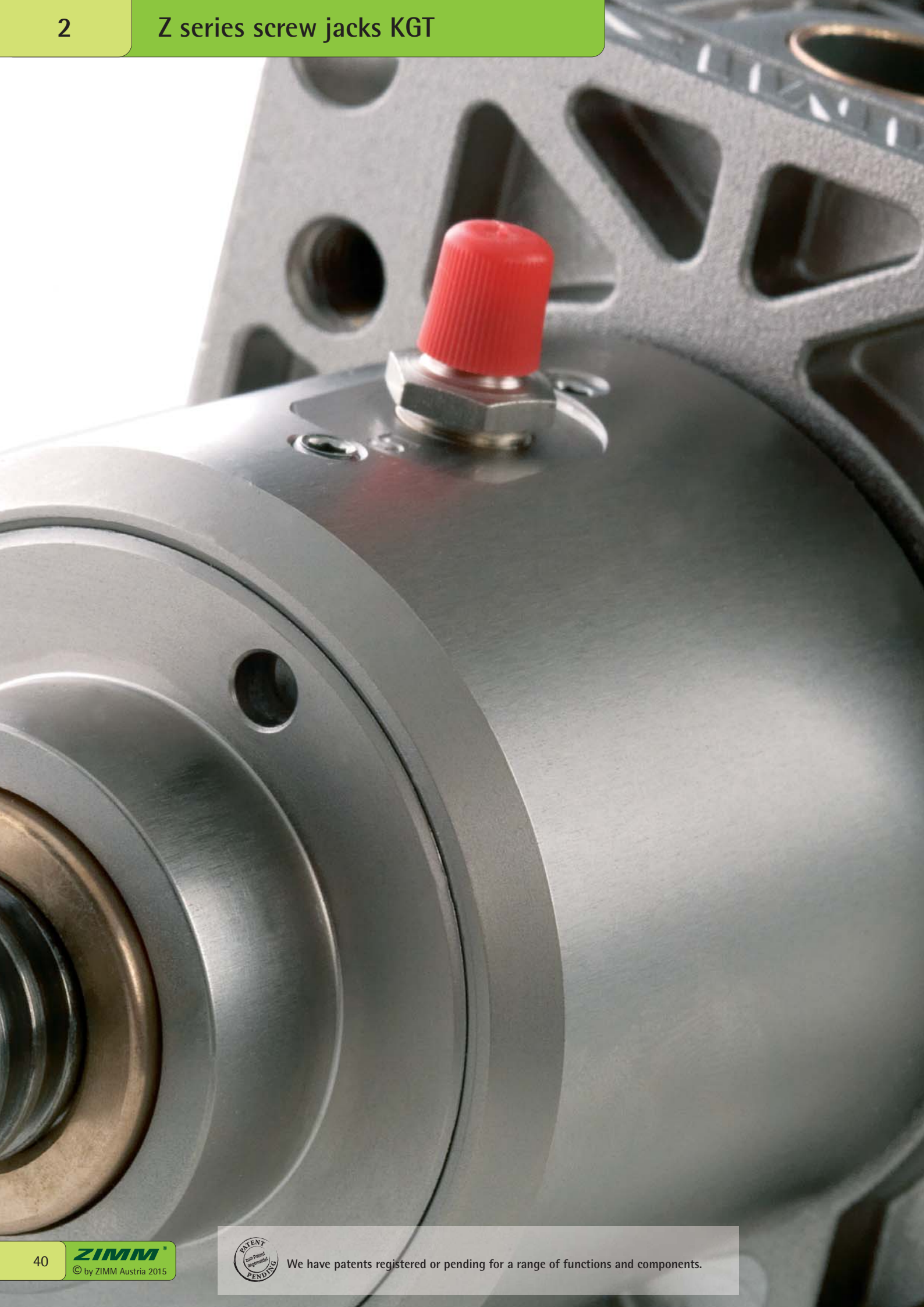

## Ball screw KGT



Most screw jacks use trapezoidal screws Tr, because they are simple, robust and inexpensive. The proportion of screw jacks that use ball screws is however constantly increasing. The reasons for this are primarily their pitch accuracy, their high efficiency (less power consumption and less heat generation) and the higher pitches available, which permit higher stroke speeds.

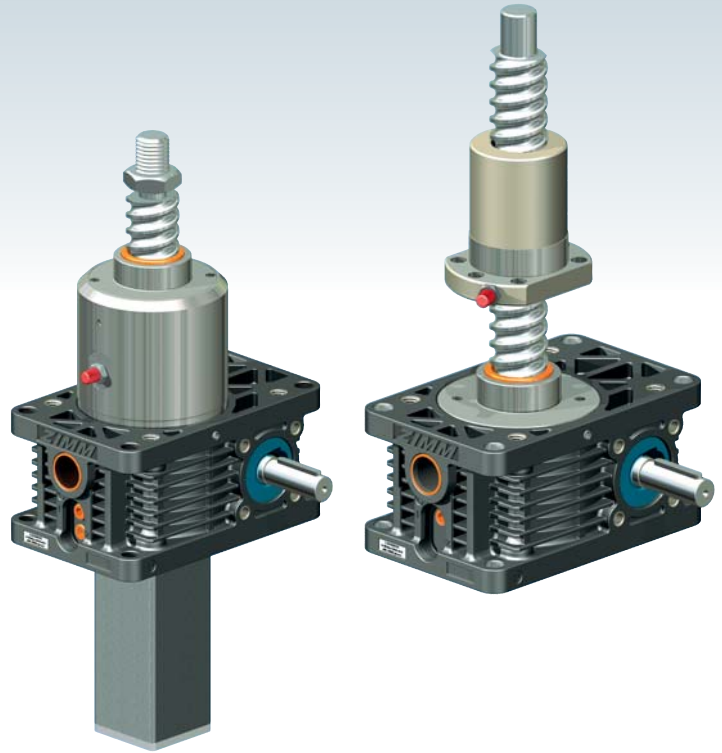

## Technical data KGT

### Pitch accuracy

0.05 mm / 300 mm

Material: 1.1213 (Cf 53), induction hardened and polished.

### No self-locking!

Because of the lack of friction, a holding brake is necessary: a motor brake or a spring pressure brake is required.

### Temperatures, duty cycle

Operating temperature range -20°C to +80°C (when <10° or >40°C please contact us).

The duty cycle can be up to 4 times higher than for trapezoidal screws (see diagrams), and at long strokes up to 2 times higher than for trapezoidal screws.

### Service life

Heavy loads reduce the service life of the KGT. Tell us the load and stroke speed and we will calculate the service life.

### Contamination

All nuts are fitted with scrapers. For heavy contamination and fine dust/chips, we recommend fitting bellows or a spiral spring cover.

### Escape/rotation protection

Under no circumstances may the nut be screwed off the screw. We therefore always provide escape/rotation protection on the S version.

### Start ramp / braking ramp

We recommend using a frequency converter or a servomotor, especially for high lead screw jacks. This allows regulation of the start ramp / braking ramp. This ensures protection for the entire system.

Safety clearance L3 can also be reduced at your own discretion, in particular for high pitches.

### Grease nipples

The standard position of the grease nipple on the S version is on the gearbox face "C". Optionally, face A is available. Faces B and D are available on request.





UNIQUE:  
Ball screw lubrication  
for the S version

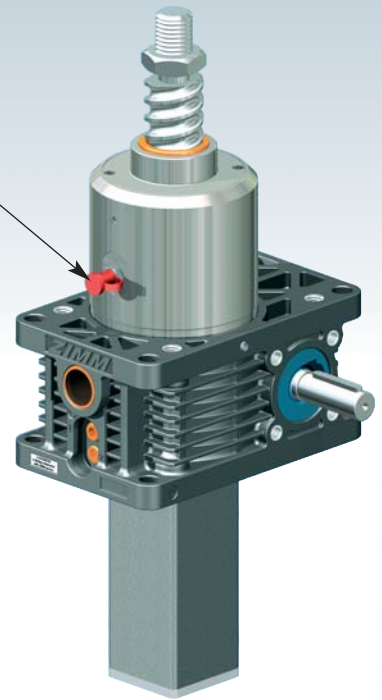

## Z-5 to Z-25, KGT-S translating screw

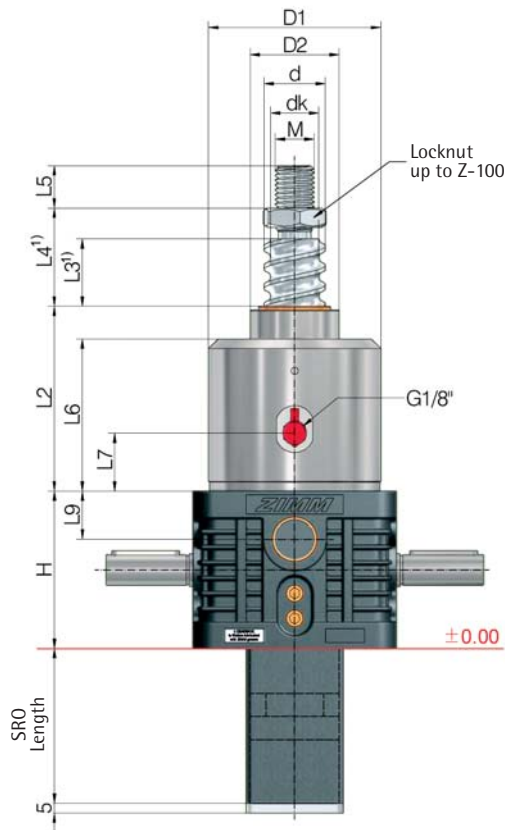

- further technical information: Page 41
- see the respective screw jack page for all other dimensions
- see Section 4 for accessories
- dimensions on the illustrative diagrams are in mm. We reserve the right to make changes.

### Ordering example:

Z-25-SN-KGT 32x10, C = 33.4 kN

dynamic load rating C

Screw jacks	Ball screw KGT	Stroke per drive revolution [mm]		KGT load rating [kN]		Dimensions [mm]													Axial play max <sup>5)</sup> [mm]
		SN	SL	dyn. C <sup>2)</sup>	stat. C <sub>0</sub> =C <sub>0a</sub>	H	d	dk	D <sub>1</sub>	D <sub>2</sub>	L <sub>2</sub>	L <sub>3</sub> <sup>1)</sup>	L <sub>4</sub> <sup>1)</sup>	L <sub>5</sub>	L <sub>6</sub>	L <sub>7</sub>	L <sub>9</sub>	M	
Z-5	16x5	1.25	0.31	9.3	13.1	62	15.5	12.9	59	29	66	15	25	19	54	23	18	M12	0.08
	16x10	2.50	0.63	15.4	26.5	62	15.4	13.0	59	29	66	25	35	19	54	23	18	M12	0.08
Z-10	25x5	1.25	0.31	12.3	22.5	74	24.5	21.9	69	39	85	15	27	20	69	21	21	M14	0.08
	25x10	2.50	0.63	13.2	25.3	74	24.5	21.9	69	39	85	25	37	20	69	21	21	M14	0.08
	25x25	6.25	1.56	16.7	32.2	74	24.5	22.0	69	39	85	60	72	20	69	21	21	M14	0.08
	25x50	12.50	3.13	15.4	31.7	74	24.1	21.5	69	39	85	125	137	20	69	21	21	M14	0.15
Z-25	32x5	0.83	0.21	21.5	49.3	82	31.5	28.9	89	46	99	15	31	22	82	33	25	M20	0.08
	32x10	1.67	0.42	33.4	54.5	82	32.7	27.3	89	46	99	20	36	22	82	33	25	M20	0.08
	32x20	3.33	0.83	29.7	59.8	82	31.7	27.9	89	46	99	35	51	22	82	33	25	M20	0.08
	32x40	6.67	1.67	14.9	32.4	82	30.9	28.3	89	46	99	70	86	22	82	33	25	M20	0.08

<sup>1)</sup> Depending on the control system and drive, the dimensions L<sub>3</sub> and L<sub>4</sub> can be reduced at your own discretion, in particular for high pitches. An extension may be required if a bellows or spiral spring extension is fitted

<sup>2)</sup> Dynamic load rating to DIN 69051 part 4 draft 1989

<sup>5)</sup> Reduced play 0.02 mm available on request



Z-5 to Z-25, KGT-R rotating screw

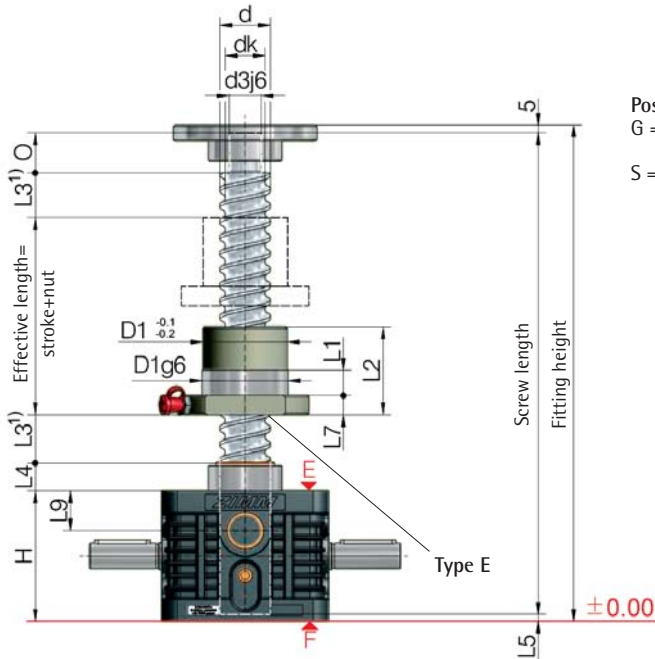
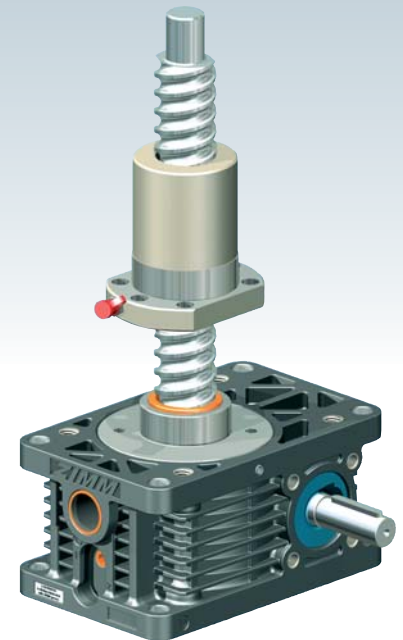

Position of the flanged nut:  
 G = flange gearbox side (as shown)  
 S = flange screw side

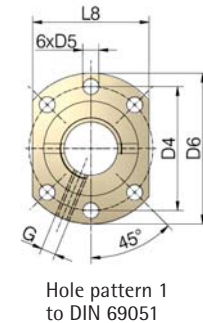
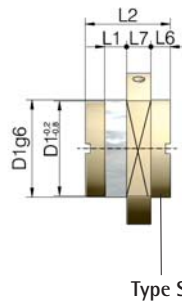

Hole pattern 1 to DIN 69051

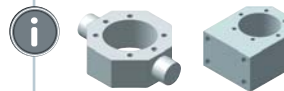

Adapter for KGT  
 Dimension sheet on request (up to KGT Ø50)

- further technical information: Page 41
- see the respective screw jack page for all other dimensions
- see Section 4 for accessories
- dimensions on the illustrative diagrams are in mm. We reserve the right to make changes.

**Ordering example:**

Z-25-RN-KGT 32x10, C = 33.4 kN - G

dynamic load rating C  
 Nut flange  
 G: flange gearbox side  
 S: flange screw side

Screw jacks	Ball screw KGT	Stroke per drive revolution [mm]		KGT load rating [kN]		Nut Type	Hole pattern	Dimensions [mm]																Lubrication hole	Axial play max <sup>5)</sup> [mm]		
		RN	RL	dyn. C <sup>2)</sup>	stat. C <sub>0</sub> =C <sub>0a</sub>			d	d <sub>k</sub>	d <sub>3</sub>	O	H	D <sub>1</sub>	D <sub>4</sub>	D <sub>5</sub>	D <sub>6</sub>	L <sub>1</sub>	L <sub>2</sub>	L <sub>3</sub> <sup>1)</sup>	L <sub>4</sub>	L <sub>5</sub>	L <sub>6</sub>	L <sub>7</sub>			L <sub>8</sub>	L <sub>9</sub>
Z-5	16x5	1.25	0.31	9.3	13.1	E	1	15.5	12.9	12	15	62	28	38	5.5	48	10	42	15	12	8	-	10	40	18	M6	0.08
	16x10	2.50	0.63	15.4	26.5	E	1	15.4	13.0	12	15	62	28	38	5.5	48	10	55	25	12	8	-	10	40	18	M6	0.08
Z-10	25x5	1.25	0.31	12.3	22.5	E	1	24.5	21.9	15	20	74	40	51	6.6	62	10	42	15	16	8	-	10	48	21	M6	0.08
	25x10	2.50	0.63	13.2	25.3	E	1	24.5	21.9	15	20	74	40	51	6.6	62	16	55	25	16	8	-	10	48	21	M6	0.08
	25x25 <sup>3)</sup>	6.25	1.56	16.7	32.2	S	1	24.5	22.0	15	20	74	40	51	6.6	62	9	35	60	16	8	8	10	- <sup>3)</sup>	21	M6	0.08
Z-25	25x50	12.50	3.14	15.4	31.7	S	1	24.1	21.5	15	20	74	40	51	6.6	62	10	58	125	16	8	10	10	48	21	M6	0.15
	32x5	0.83	0.21	21.5	49.3	E	1	31.5	28.9	20	25	82	50	65	9.0	80	10	55	15	17	5	-	12	62	25	M6	0.08
	32x10	1.67	0.42	33.4	54.5	E	1	32.7	27.3	20	25	82	53 <sup>6)</sup>	65	9.0	80	16	69	20	17	5	-	12	62	25	M8x1	0.08
	32x20	3.33	0.83	29.7	59.8	E	1	31.7	27.9	20	25	82	53 <sup>6)</sup>	65	9.0	80	16	80	35	17	5	-	12	62	25	M6	0.08
	32x40 <sup>3)</sup>	6.67	1.67	14.9	32.4	S	N <sup>4)</sup>	30.9	28.3	20	25	82	53 <sup>6)</sup>	68 <sup>6)</sup>	7.0 <sup>6)</sup>	80	14	45	70	17	5	7.5	16	- <sup>3)</sup>	25	M6	0.08

An increased screw (such as: Z-10-RN with screw 32x10) can also be used for the rotating version.

<sup>1)</sup> An extension may be required if a bellows or spiral spring is fitted  
<sup>2)</sup> Dynamic load rating to DIN 69051 part 4 draft 1989  
<sup>3)</sup> Round flange  
<sup>4)</sup> Hole pattern on request  
<sup>5)</sup> Reduced play 0.02 mm available on request

<sup>6)</sup> Not to DIN 69051



UNIQUE:  
Ball screw lubrication  
for the S version

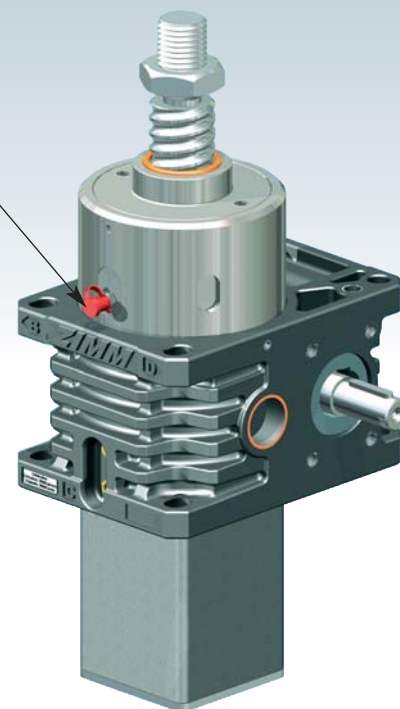

## Z-50 to Z-150, KGT-S translating screw

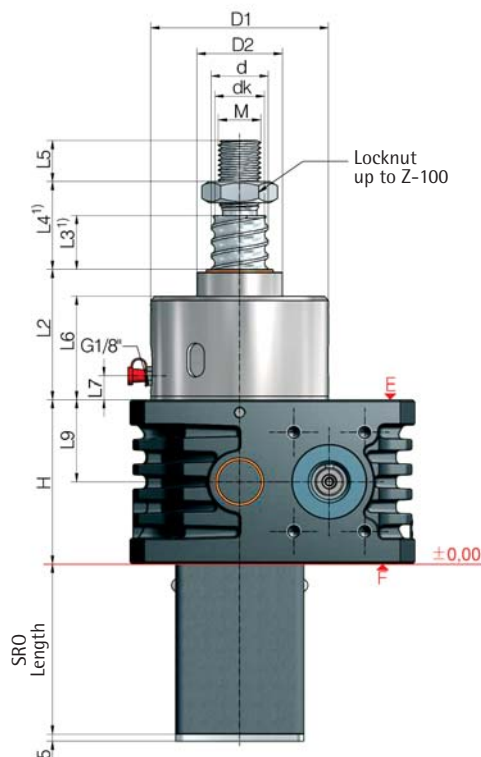

- further technical information: Page 41
  - see the respective screw jack page for all other dimensions
  - see Section 4 for accessories
  - dimensions on the illustrative diagrams are in mm.
- We reserve the right to make changes.

### Ordering example:

Z-100-SN-KGT 50x20, C = 112.4 kN

dynamic load rating C

Screw jacks	Ball screw KGT	Stroke per drive revolution [mm]		KGT load rating [kN]		Dimensions [mm]													Axial play max <sup>5)</sup> [mm]
		SN	SL	dyn. C <sup>2)</sup>	stat. C <sub>0</sub> =C <sub>0a</sub>	H	d	d <sub>k</sub>	D <sub>1</sub>	D <sub>2</sub>	L <sub>2</sub>	L <sub>3</sub> <sup>1)</sup>	L <sub>4</sub> <sup>1)</sup>	L <sub>5</sub>	L <sub>6</sub>	L <sub>7</sub>	L <sub>9</sub>	M	
Z-50	40x5	0.71	0.18	23.8	63.1	116	39.5	36.9	125	60	93	15	39	29	74	17	58	M30	0.08
	40x10	1.43	0.36	38	69.1	116	39.5	34.1	125	60	93	15	39	29	74	17	58	M30	0.08
	40x20	2.86	0.72	33.3	76.1	116	39.7	35.9	125	60	93	30	54	29	74	17	58	M30	0.08
Z-100	40x40	5.71	1.43	35	101.9	116	38.9	36.3	125	60	93	60	84	29	74	17	58	M30	0.08
	50x10	1.11	0.28	68.7	155.8	160	49.5	44.1	148	85	112	20	48	48	82	19	80	M36	0.08
	50x20	2.22	0.56	60	136.3	160	49.5	44.1	148	85	112	40	68	48	82	19	80	M36	0.08
	50x10	1.11	0.28	112.1	338.5	160	50	43.6	148	85	148	20	48	48	118	19	80	M36	0.03
	50x20	2.22	0.56	112.4	214.7	160	50	41.1	148	85	148	40	68	48	118	19	80	M36	0.03
Z-150	50x40	4.44	1.11	84.7	143.1	160	50	41.1	148	85	148	80	108	48	118	19	80	M36	0.03
	63x10	1.11	0.28	150.2	598.4	185	63	56.6	168	90	150	20	40	48	118	24	92.5	M42x2	0.03
	63x20	2.22	0.56	173.5 <sup>7)</sup>	346.2	185	63	51.8	168	90	150	40	40	48	118	24	92.5	M42x2	0.03
	63x40	4.44	1.11	96.6	205.1	185	63	54.1	168	90	150	80	80	48	118	24	92.5	M42x2	0.03
	63x60 <sup>4)</sup>	6.67	1.67	59.5	102.5	185	63	54.1	168	90	150	120	120	48	118	24	92.5	M42x2	0.03

<sup>1)</sup> Depending on the control system and drive, the dimensions L<sub>3</sub> and L<sub>4</sub> can be reduced at your own discretion, in particular for high pitches. An extension may be required if a bellows or spiral spring is fitted.

<sup>2)</sup> Dynamic load rating to DIN 69051 part 4 draft 1989

<sup>4)</sup> Non-preferred design

<sup>5)</sup> Reduced play 0.02 mm available on request

<sup>7)</sup> Service life calculation with C<sub>dyn</sub> 159 kN (gearbox bearing)

Ball screw  
KGT

## Z-35 to Z-150, KGT-R rotating ball screw

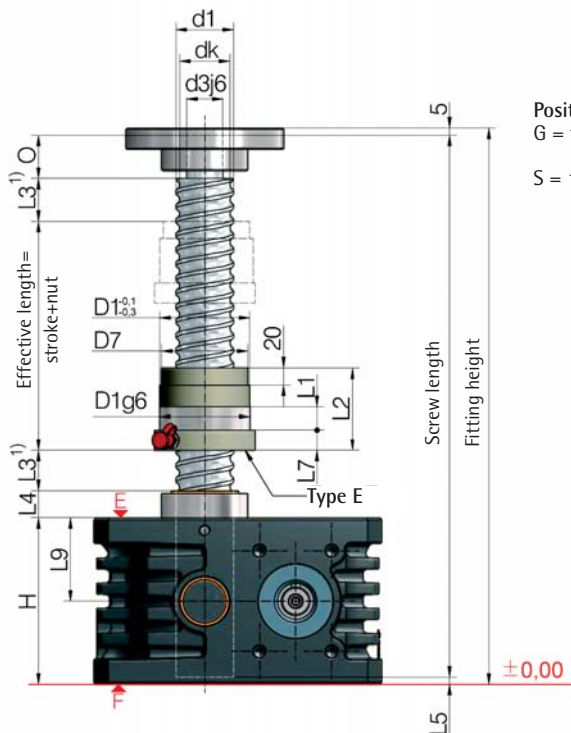

Position of the flanged nut:

G = flange gearbox side  
(as shown)

S = flange screw side

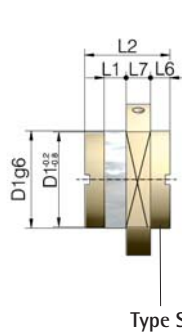
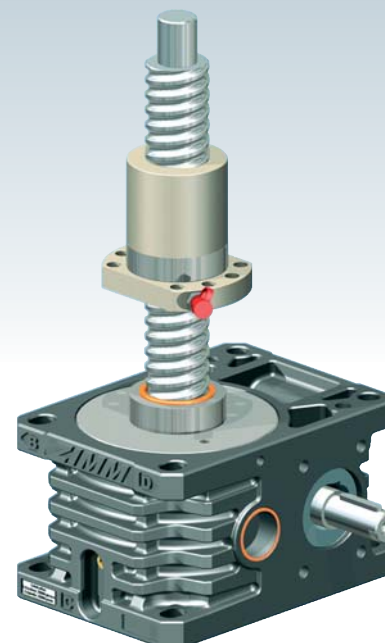

Type S

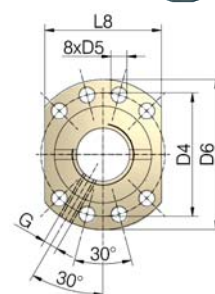
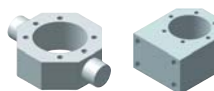
Hole pattern 2 to  
DIN 69051Adapter for KGT  
Dimension sheet on request  
(up to KGT Ø50)

Ordering example:

Z-100-RN-KGT 50x20, C = 112.4 kN - G

dynamic load rating C

Nut flange

G: flange gearbox side

S: flange screw side



- further technical information: Page 41
  - see the respective screw jack page for all other dimensions
  - see Section 4 for accessories
  - dimensions on the illustrative diagrams are in mm.
- We reserve the right to make changes.

Screw jacks	Ball screw KGT	Stroke per drive revolution [mm]		KGT load rating [kN]		Nut Type	Hole pattern	Dimensions [mm]																			Lubrication hole G	Axial play max <sup>5)</sup> [mm]
		RN	RL	dyn. C <sup>2)</sup>	stat. C <sub>0</sub> =C <sub>0b</sub>			d	d <sub>k</sub>	d <sub>3</sub>	O	H	D <sub>1</sub>	D <sub>4</sub>	D <sub>5</sub>	D <sub>6</sub>	D <sub>7</sub>	L <sub>1</sub>	L <sub>2</sub>	L <sub>3</sub> <sup>1)</sup>	L <sub>4</sub>	L <sub>5</sub>	L <sub>6</sub>	L <sub>7</sub>	L <sub>8</sub>	L <sub>9</sub>		
Z-35	40x5	0.71	0.18	23.8	63.1	E 2	2	39.5	36.9	25	30	100	63	78	9	93	-	10	57	15	19	7	-	14	70	50 <sup>7)</sup>	M6	0.08
	40x10	1.43	0.36	38	69.1	E 2	2	39.5	34.1	25	30	100	63	78	9	93	-	16	71	15	19	7	-	14	70	50 <sup>7)</sup>	M8x1	0.08
	40x20	2.86	0.72	33.3	76.1	E 2	2	39.7	35.9	25	30	100	63	78	9	93	-	16	80	30	19	7	-	14	70	50 <sup>7)</sup>	M8x1	0.08
	40x40 <sup>3)</sup>	5.71	1.43	35	101.9	S 2	2	38.9	36.3	25	30	100	63	78	9	93	-	16	85	60	19	7	7,5	14	- <sup>3)</sup>	50 <sup>7)</sup>	M8x1	0.08
Z-50	40x5	0.71	0.18	23.8	63.1	E 2	2	39.5	36.9	25	30	116	63	78	9	93	-	10	57	15	19	7	-	14	70	58 <sup>7)</sup>	M6	0.08
	40x10	1.43	0.36	38	69.1	E 2	2	39.5	34.1	25	30	116	63	78	9	93	-	16	71	15	19	7	-	14	70	58 <sup>7)</sup>	M8x1	0.08
	40x20	2.86	0.72	33.3	76.1	E 2	2	39.7	35.9	25	30	116	63	78	9	93	-	16	80	30	19	7	-	14	70	58 <sup>7)</sup>	M8x1	0.08
	40x40 <sup>3)</sup>	5.71	1.43	35	101.9	S 2	2	38.9	36.3	25	30	116	63	78	9	93	-	16	85	60	19	7	7,5	14	- <sup>3)</sup>	58 <sup>7)</sup>	M8x1	0.08
Z-100	50x10	1.11	0.28	68.7	155.8	E 2	2	49.5	44.1	40	45	160	75	93	11	110	-	16	95	20	30	8	-	16	85	80	M8x1	0.08
	50x20	2.22	0.56	60	136.3	E 2	2	49.5	44.1	40	45	160	85 <sup>6)</sup>	103 <sup>6)</sup>	11	125 <sup>6)</sup>	-	22	95	40	30	8	-	18	95	80	M8x1	0.08
	50x10	1.11	0.28	112.1	338.5	E 2	2	50	43.6	40	45	160	75	93	11	110	-	16	107	20	30	8	-	16	85	80	M8x1	0.03
	50x20	2.22	0.56	112.4	214.7	E 2	2	50	41.1	40	45	160	85 <sup>6)</sup>	103 <sup>6)</sup>	11	120 <sup>6)</sup>	-	16	125	40	30	8	-	16	95	80	M8x1	0.03
	50x40	4.44	1.11	84.7	143.1	E 2	2	50	41.1	40	45	160	85 <sup>6)</sup>	103 <sup>6)</sup>	11	120 <sup>6)</sup>	-	16	125	80	30	8	-	16	95	80	M8x1	0.03
	50x50 <sup>4)</sup>	5.56	1.39	84.7	143.1	E 2	2	50	41.1	40	45	160	85 <sup>6)</sup>	103 <sup>6)</sup>	11	120 <sup>6)</sup>	-	16	145	100	30	8	-	16	95	80	M8x1	0.03
Z-150	63x10 <sup>8)</sup>	1.11	0.28	84.7	210.8	E 2	2	63	58.8	45	55	185	90	108	11	125	-	16	120	20	32	7	-	18	95	92.5 <sup>7)</sup>	M8x1	0.05
	63x20 <sup>8)</sup>	2.22	0.56	230 <sup>7)</sup>	600	E 2	2	63	50.2	45	55	185	125 <sup>6)</sup>	145 <sup>6)</sup>	13.5	165 <sup>6)</sup>	-	25	170	40	32	7	-	25	130	92.5 <sup>7)</sup>	M8x1	0.05
	63x10	1.11	0.28	150.2	598.4	E 2	2	63	56.6	45	55	185	90	108	11	125	-	16	135	20	32	7	-	18	95	92.5 <sup>7)</sup>	M8x1	0.03
	63x20	2.22	0.56	173.5 <sup>7)</sup>	346.2	E 2	2	63	51.8	45	55	185	95	115	13.5	135	90	25	135	40	32	7	-	20	100	92.5 <sup>7)</sup>	M8x1	0.03
	63x40	4.44	1.11	96.6	205.1	E 2	2	63	54.1	45	55	185	95	115	13.5	135	90	25	126	80	32	7	-	20	100	92.5 <sup>7)</sup>	M8x1	0.03
	63x60 <sup>4)</sup>	6.67	1.67	59.5	102.5	E 2	2	63	54.1	45	55	185	95	115	13.5	135	90	25	126	120	32	7	-	20	100	92.5 <sup>7)</sup>	M8x1	0.03

1) An extension may be required if a bellows or spiral spring is fitted

2) Dynamic load rating to DIN 69051 part 4 draft 1989

3) Round flange

4) Non-preferred design

5) Reduced play 0.02 mm available on request

6) Not to DIN 69051

7) Service life calculation with C<sub>dyn</sub> 159 kN (gearbox bearing)

8) Design being superseded



UNIQUE:  
Ball screw lubrication  
for the S version

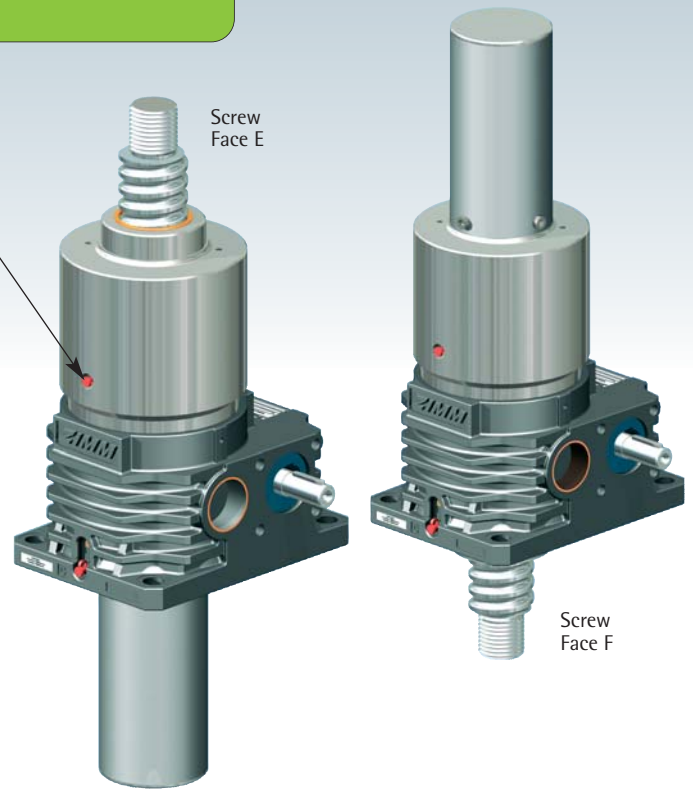

Z-250 and Z-350, KGT-S  
Translating screw

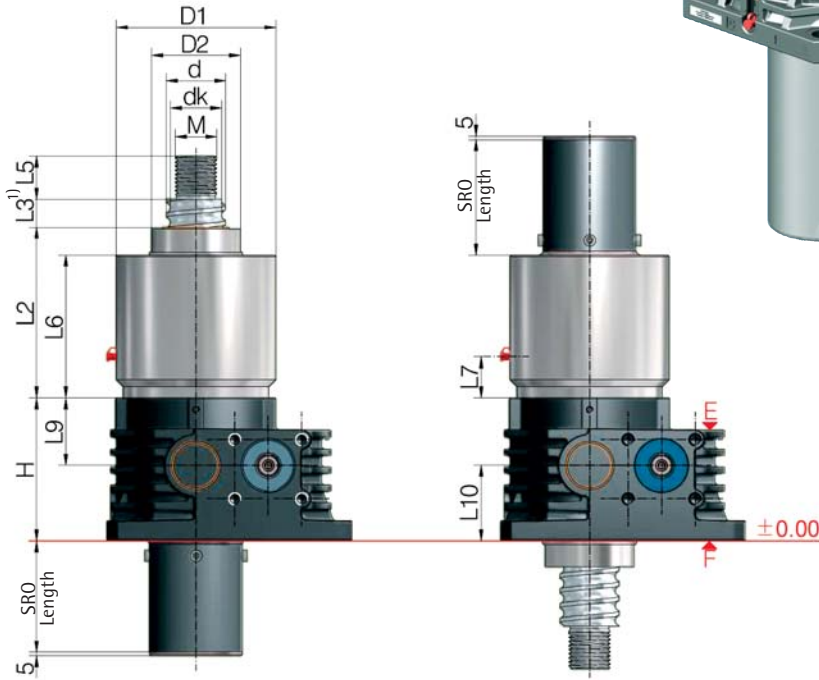

**i** - further technical information: Page 41  
 - see the respective screw jack page for all other dimensions  
 - see Section 4 for accessories  
 - dimensions on the illustrative diagrams are in mm.  
 We reserve the right to make changes.

**Shopping cart icon** **Ordering example:**  
**Z-250-SN-E-KGT 80x40, C = 251.2 kN**  
 Screw face E or F  
 dynamic load rating C

Screw jacks	Ball screw KGT ØxP	Stroke per drive revolution [mm]		KGT load rating [kN]		Dimensions [mm]													Axial play max. [mm]
		SN	SL	dyn. C <sup>2)</sup>	stat. C <sub>0</sub> =C <sub>0a</sub>	H	d	dk	D <sub>1</sub>	D <sub>2</sub>	L <sub>2</sub>	L <sub>3</sub> <sup>1)</sup>	L <sub>5</sub>	L <sub>6</sub>	L <sub>7</sub>	L <sub>9</sub>	L <sub>10</sub>	M	
Z-250	80x10 <sup>4)</sup>	0.94	0.31	193.0	993.4	193	80	73.6	216	120	228	20	58	191	45	91	102	M56x2	0.03
	80x20	1.87	0.63	359.2	942.5	193	80	67	216	120	228	40	58	191	45	91	102	M56x2	0.03
	80x40	3.75	1.25	251.2	565.5	193	80	67	216	120	228	80	58	191	45	91	102	M56x2	0.03
	80x60	5.62	1.88	189.1	377.0	193	80	67	216	120	228	120	58	191	45	91	102	M56x2	0.03
Z-350	100x20	1.87	0.63	330.2	979.1	230	100	87.4	275	145	223	40	78	199	54	115	115	M72x3	0.03
	100x40	3.75	1.25	270.0	734.0	230	100	87.4	275	145	223	80	78	199	54	115	115	M72x3	0.03
	100x60	5.62	1.88	203.0	489.6	230	100	87.4	275	145	223	120	78	199	54	115	115	M72x3	0.03
	100x80 <sup>4)</sup>	7.50	2.50	203.0	489.6	230	100	87.4	275	145	263	160	78	239	54	115	115	M72x3	0.03

<sup>1)</sup> Depending on the control system and drive, the dimension L<sub>3</sub> can be reduced at your own discretion. An extension may be required if a bellows or spiral spring is fitted

<sup>2)</sup> Dynamic load rating to DIN 69051 part 4 draft 1989

<sup>4)</sup> Non-preferred design





Z-250 and Z-350, KGT-R  
Rotating screw

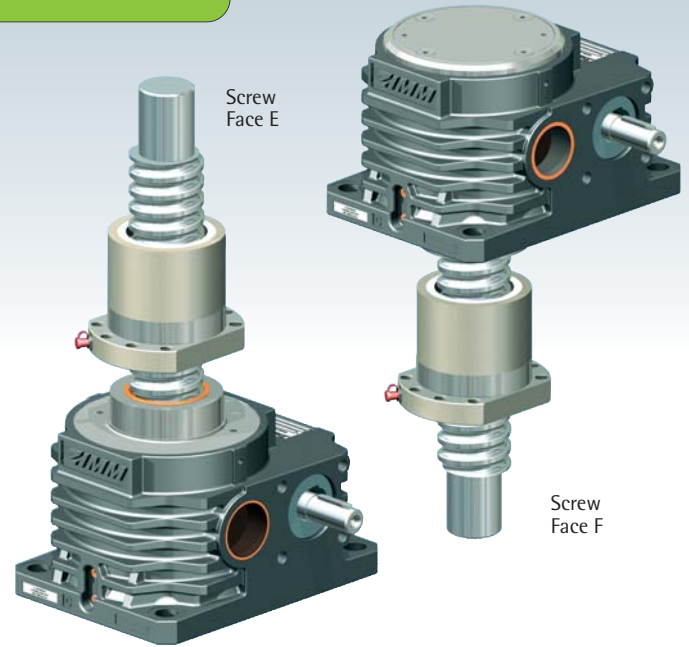
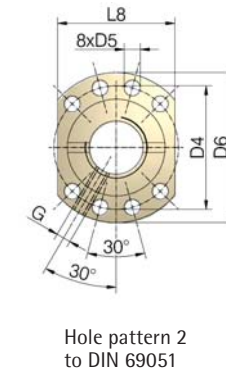
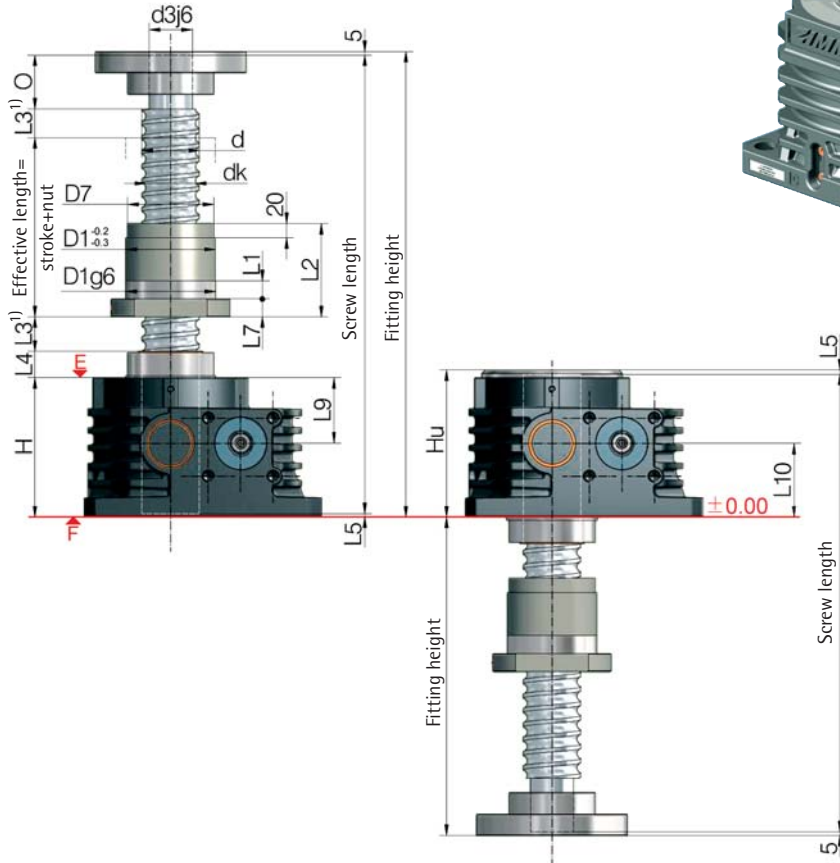

2

**i** - further technical information: Page 41  
 - see the respective screw jack page for all other dimensions  
 - see Section 4 for accessories  
 - dimensions on the illustrative diagrams are in mm.  
 We reserve the right to make changes.

**Ordering example:**  
**Z-250-RN-E-KGT 80x40, C = 112.4 kN - G**  
 Screw face E or F  
 dynamic load rating C  
 Nut flange  
 G: flange gearbox side  
 S: flange screw side

Screw jacks	Ball screw KGT	Stroke per drive revolution [mm]		KGT load rating [kN]		Nut Type	Nut Hole pattern	Dimensions [mm]														Lubri-cation hole G	Axial play max [mm]						
		RN	RL	dyn. stat. C <sup>2)</sup>	C <sub>0</sub> =C <sub>0a</sub>			d	d <sub>k</sub>	d <sub>s</sub>	O	H	H <sub>u</sub>	D <sub>1</sub>	D <sub>4</sub>	D <sub>5</sub>	D <sub>6</sub>	D <sub>7</sub>	L <sub>1</sub>	L <sub>2</sub>	L <sub>3</sub>			L <sub>4</sub>	L <sub>5</sub>	L <sub>7</sub>	L <sub>8</sub>	L <sub>9</sub>	L <sub>10</sub>
Z-250	80x10 <sup>4)</sup>	0.94	0.31	93.4	269.2	E 2	2	80	75.8	60	75	193	204	105	125	13.5	145	-	16	120	20	37	5	20	110	91	102	M8x1	0.05
	80x20 <sup>4)</sup>	1.87	0.63	320.0	820.0	E 2	2	78	68.2	60	75	193	204	135	155	13.5	175	-	25	190	40	37	5	25	140	91	102	M8x1	0.05
	80x10 <sup>4)</sup>	0.94	0.31	193.0	993.4	E 2	2	80	73.6	60	75	193	204	105	125	13.5	145	-	16	160	20	37	5	20	110	91	102	M8x1	0.03
	80x20	1.87	0.63	359.2	942.5	E 2	2	80	67	60	75	193	204	125	145	13.5	165	120	25	190	40	37	5	25	130	91	102	M8x1	0.03
	80x40	3.75	1.25	251.2	565.5	E 2	2	80	67	60	75	193	204	125	145	13.5	165	120	25	190	80	37	5	25	130	91	102	M8x1	0.03
Z-350	80x60	5.62	1.88	189.1	377.0	E 2	2	80	67	60	75	193	204	125	145	13.5	165	120	25	190	120	37	5	25	130	91	102	M8x1	0.03
	100x20	1.87	0.63	330.2	979.1	E 2	2	100	87.4	80	100	230	230	150	176	17.5	202	145	25	175	40	24	6	30	155	115	115	M8x1	0.03
	100x40	3.75	1.25	270.0	734.0	E 2	2	100	87.4	80	100	230	230	150	176	17.5	202	145	25	175	80	24	6	30	155	115	115	M8x1	0.03
	100x60	5.62	1.88	203.0	489.6	E 2	2	100	87.4	80	100	230	230	150	176	17.5	202	145	25	175	120	24	6	30	155	115	115	M8x1	0.03
	100x80	7.50	2.50	203.0	489.6	E 2	2	100	87.4	80	100	230	230	150	176	17.5	202	145	25	215	160	24	6	30	155	115	115	M8x1	0.03

<sup>1)</sup> An extension may be required if a bellows or spiral spring is fitted  
<sup>2)</sup> Dynamic load rating to DIN 69051 part 4 draft 1989

<sup>4)</sup> Non-preferred design



UNIQUE:  
Ball screw lubrication for  
the S version

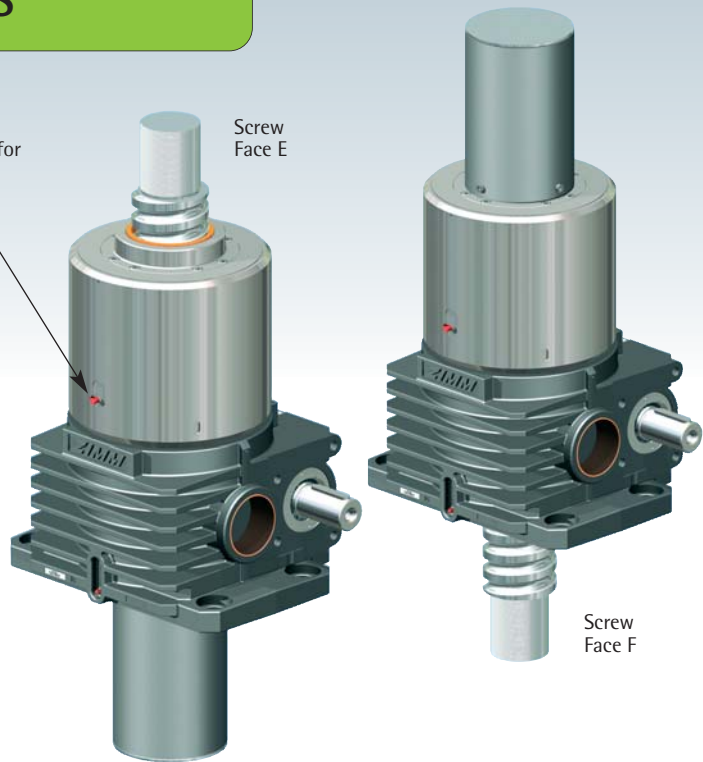

Z-500 to Z-1000, KGT-S  
Translating screw

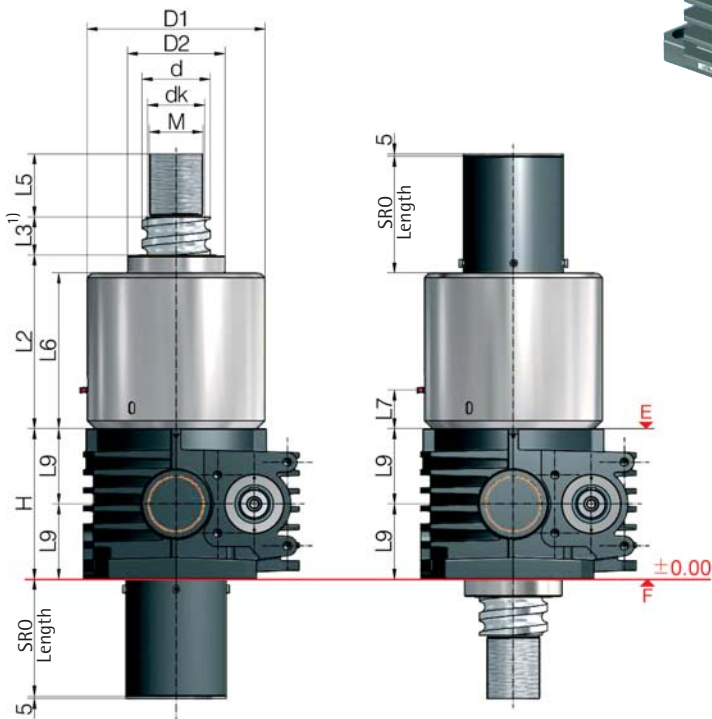

**i** - further technical information: Page 41  
 - see the respective screw jack page for all other dimensions  
 - see Section 4 for accessories  
 - dimensions on the illustrative diagrams are in mm.  
 We reserve the right to make changes.

**🛒** Ordering example:  
 Z-1000-SN-E-KGT 160x40, C = 1069.9 kN  
 Screw face E or F  
 dynamic load rating C

Screw jacks	Ball screw KGT	Stroke per drive revolution [mm]		KGT load rating [kN]		Dimensions [mm]											Axial play max. [mm]	
		SN	SL	dyn. C <sup>2)</sup>	stat. C <sub>0</sub> =C <sub>0a</sub>	H	d	dk	D <sub>1</sub>	D <sub>2</sub>	L <sub>2</sub>	L <sub>3</sub> <sup>1)</sup>	L <sub>5</sub>	L <sub>6</sub>	L <sub>7</sub>	L <sub>9</sub>		M
Z-500	125x25	2.34	0.78	575.1	1863	260	125	107.8	315	170	283	50	118	251	55	130	M100x3	0.03
	125x40	3.75	1.25	402.2	1117	260	125	107.8	315	170	283	80	118	251	55	130	M100x3	0.03
	125x60	5.62	1.88	302.8	745.3	260	125	107.8	315	170	283	120	118	251	55	130	M100x3	0.03
	125x80	7.50	2.50	218.7	630.5	260	125	112.4	315	170	283	160	118	251	55	130	M100x3	0.03
Z-750	140x25	1.88	0.63	774.3	3082	310	140	122.8	365	200	374	50	130	337	84	155	M110x3	0.03
	140x40	3.00	1.00	754.0	2100	310	140	117	365	200	374	80	130	337	84	155	M110x3	0.03
	140x60	4.50	1.50	616.7	1575	310	140	117	365	200	374	120	130	337	84	155	M110x3	0.03
	140x80	6.00	2.00	464.3	1048	310	140	117	365	200	374	160	130	337	84	155	M110x3	0.03
Z-1000	160x25	1.88	0.63	884.7	4068	340	160	142.8	405	250	392	50	130	360	79	170	M110x3	0.03
	160x40	3.00	1.00	1069.9	3016	340	160	132.8	405	250	392	80	130	360	79	170	M110x3	0.03
	160x60	4.50	1.50	663.0	1923	340	160	137	405	250	392	120	130	360	79	170	M110x3	0.03
	160x80	6.00	2.00	499.1	1282	340	160	137	405	250	392	160	130	360	79	170	M110x3	0.03

<sup>1)</sup> Depending on the control system and drive, the dimension L<sub>3</sub> can be reduced at your own discretion. An extension may be required if a bellows or spiral spring is fitted

<sup>2)</sup> Dynamic load rating to DIN 69051 part 4 draft 1989



Z-500 to Z-1000, KGT-R  
Rotating screw

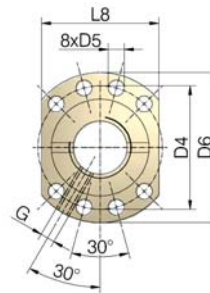
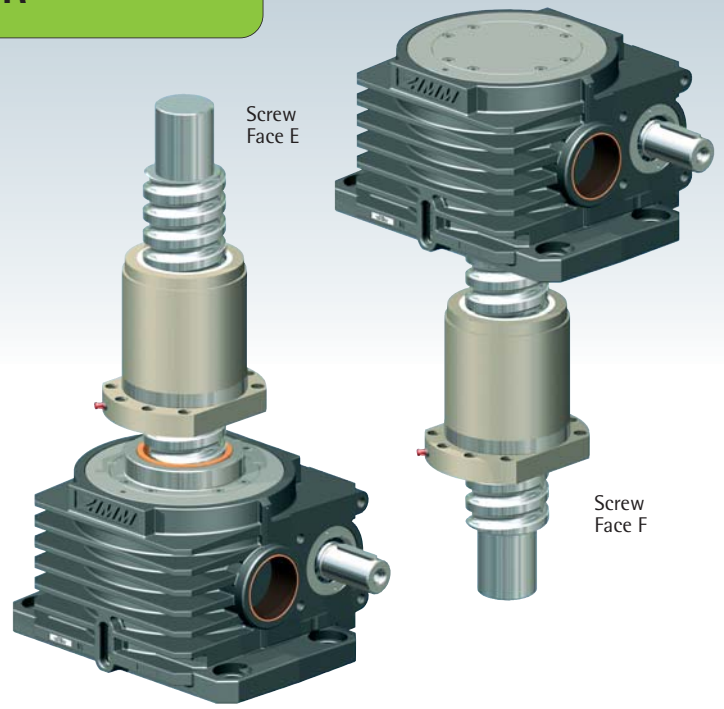
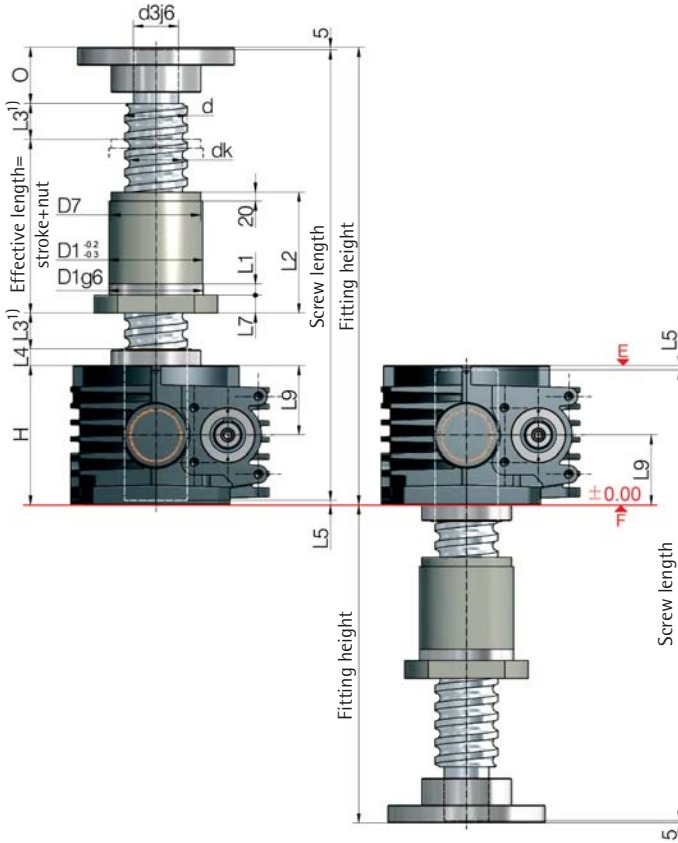

Hole pattern 2 to DIN 69051

- further technical information: Page 41
  - see the respective screw jack page for all other dimensions
  - see Section 4 for accessories
  - dimensions on the illustrative diagrams are in mm.
- We reserve the right to make changes

**Ordering example:**  
**Z-1000-RN-E-KGT 160x40, C = 1069.9 kN - G**  
 Screw face E or F  
 dynamic load rating C  
 Nut flange  
 G: flange gearbox side  
 S: flange screw side

Screw jacks	Ball screw KGT	Stroke per drive revolution [mm]		KGT load rating [kN]		Nut Type	Hole pattern	Dimensions [mm]																Lubri-cation hole	Axial play max [mm]		
		RN	RL	dyn. C <sup>2)</sup>	stat. C <sub>0</sub> =C <sub>0a</sub>			d	d <sub>k</sub>	d <sub>3</sub>	O	H	D <sub>1</sub>	D <sub>4</sub>	D <sub>5</sub>	D <sub>6</sub>	D <sub>7</sub>	L <sub>1</sub>	L <sub>2</sub>	L <sub>3</sub> <sup>1)</sup>	L <sub>4</sub>	L <sub>5</sub>	L <sub>7</sub>			L <sub>8</sub>	L <sub>9</sub>
Z-500	125x25	2.34	0.78	575.1	1863	E 2	2	125	107.8	95	120	260	185	212	17.5	240	170	25	250	50	32	6	30	190	130	M8x1	0.03
	125x40	3.75	1.25	402.2	1117	E 2	2	125	107.8	95	120	260	185	212	17.5	240	170	25	250	80	32	6	30	190	130	M8x1	0.03
	125x60	5.62	1.88	302.8	745.3	E 2	2	125	107.8	95	120	260	185	212	17.5	240	170	25	180	120	32	6	30	190	130	M8x1	0.03
	125x80	7.50	2.50	218.7	630.5	E 2	2	125	112.4	95	120	260	185	212	17.5	240	170	25	220	160	32	6	30	190	130	M8x1	0.03
Z-750	140x25	1.88	0.63	774.3	3082	E 2	2	140	122.8	100	120	310	210	243	22	275	200	25	310	50	37	10	40	215	115	M8x1	0.03
	140x40	3.00	1.00	754.0	2100	E 2	2	140	117	100	120	310	210	243	22	275	200	25	310	80	37	10	40	215	115	M8x1	0.03
	140x60	4.50	1.50	616.7	1575	E 2	2	140	117	100	120	310	225	260	22	295	200	25	280	120	37	10	40	230	115	M8x1	0.03
	140x80	6.00	2.00	464.3	1048	E 2	2	140	117	100	120	310	225	260	22	295	200	25	260	160	37	10	40	230	115	M8x1	0.03
Z-1000	160x25	1.88	0.63	884.7	4068	E 2	2	160	142.8	130	175	340	225	260	22	295	-	25	345	50	31	13	40	230	170	M8x1	0.03
	160x40	3.00	1.00	1069.9	3016	E 2	2	160	132.8	130	175	340	260	300	22	340	250	40	310	80	31	13	40	265	170	M8x1	0.03
	160x60	4.50	1.50	663.0	1923	E 2	2	160	137	130	175	340	260	300	22	340	250	40	295	120	31	13	40	265	170	M8x1	0.03
	160x80	6.00	2.00	499.1	1282	E 2	2	160	137	130	175	340	260	300	22	340	250	40	275	160	31	13	40	265	170	M8x1	0.03

<sup>1)</sup> An extension may be required if a bellows or spiral spring is fitted  
<sup>2)</sup> Dynamic load rating to DIN 69051 part 4 draft 1989



## Safety nut SIFA



### Function

A safety nut is designed for use where stripping and break up of the thread could cause a hazard to persons.

A safety nut can also provide protection for other equipment against the consequences of machine failures and downtimes.

### Wear

Once the wear exceeds max. 25% of the screw pitch, the load nut (R) or the gearbox (S) must be replaced.

### Monitoring

Wear and thread play should be checked and documented at regular intervals (depending on the duty cycle).

This allows the fitting of replacement parts to be planned ahead, reducing unscheduled system downtime.

### Electrical monitoring

Electrical monitoring gives a signal when wear reaches approx. 25%. This signal can be displayed immediately at a central control point. Replacement of the worn parts can then be scheduled.

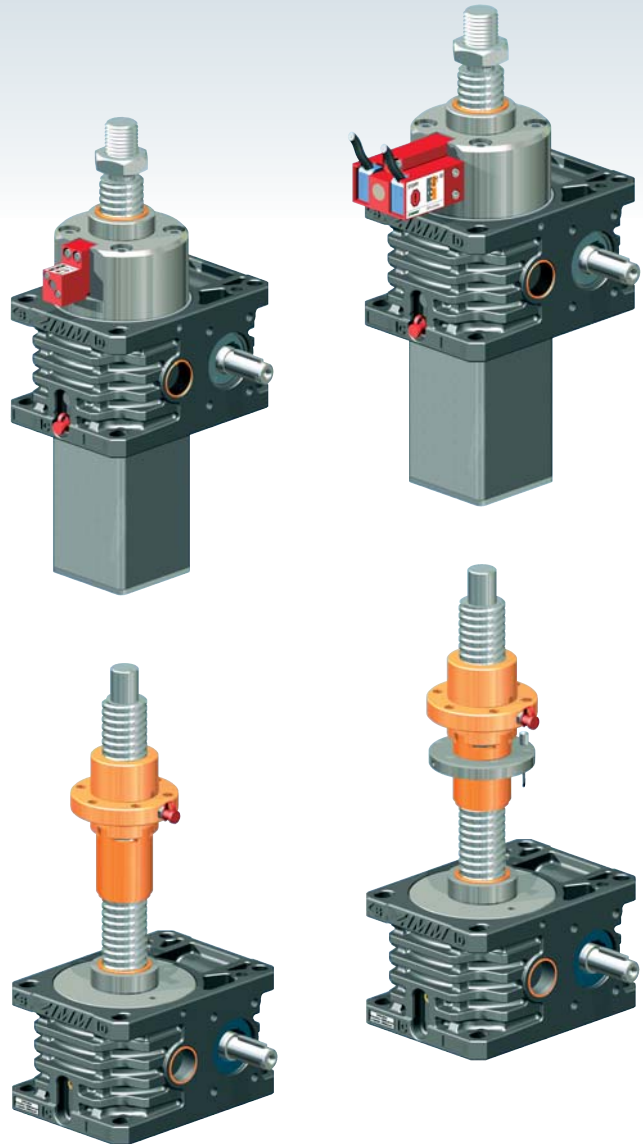

Screw jacks	Pitch P	max. permissible wear/ thread play* (25% of P)
[TrØxP]	[mm]	[mm]
Tr16x4, Tr18x4, Tr20x4	4	1.0
Tr30x6	6	1.5
Tr40x7	7	1.75
Tr50x8	8	2.0
Tr55x9, Tr60x9	9	2.25
Tr80x16, Tr100x16, Tr120x16	16	4.0
Tr140x20, Tr160x20	20	5.0

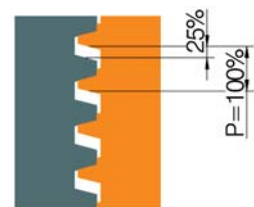

max. 25% wear

\* Identical for double pitch screws (same thread flank thickness)



We have patents registered or pending for a range of functions and components.



SIFA-S translating screw

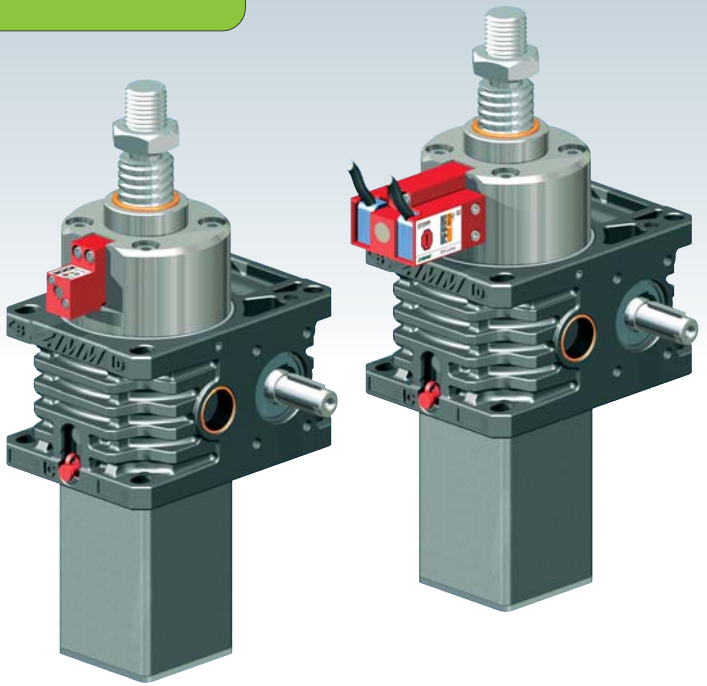
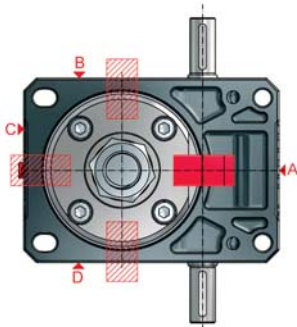
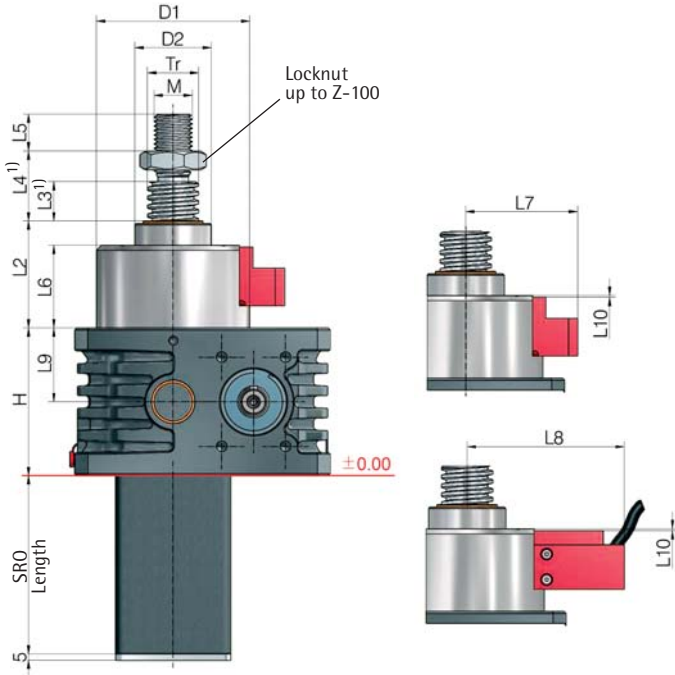

Function S version



The load is borne by the worm wheel via the screw. If the worm wheel screw thread wears through, the SIFA restrains the screw. The load remains supported.

Direction of loading, compressive and tensile  
The new SIFA-S operates equally in both compressive and tensile directions of loading!



Ordering code:

Z-35-SN-SIFA-OP-A

Version  
SN or SL  
Monitoring  
OP: visual  
EL: electrical (wear, thread stripping)  
ELV: only wear  
ELD: only thread stripping  
NO: without any monitoring  
Position  
A (standard), B, C or D  
(can also subsequently be rotated steplessly through 360°)

**i** further technical information: Page 51

Screw jacks	Stroke travel/rev.		Tr thread	H	D1	D2	L2	L3 <sup>1)</sup>	L4 <sup>1)</sup>	L5	L6	L7	L8	L9	L10	M
	SN	SL														
Z-10	1	0.25	20x4	74	81	39	74	10	22	20	58	72	108	21	1	M14
Z-25	1	0.25	30x6	82	92	46	76	10	26	22	59	79	114	25	1	M20
Z-35	1	0.25	40x7	100	100	60	80	10	34	29	61	82	117	50	1	M30
Z-50	1	0.25	40x7	116	120	60	84	10	34	29	65	88	123	58	1	M30
Z-100	1	0.25	55x9	160	135	85	103	20	48	48	73	95	130	80	9	M36
Z-150	1	0.25	60x9	185	161	90	113	20	20	48	81	107	141	92.5	6	M42x2
Z-250	1.5	0.50	80x16	193	210	120	169	20	20	58	137	117	152	91	13	M56x2
Z-350	1.5	0.50	100x16	230	-	145	174	20	20	78	155	-	-	115	-	M72x3

up to Z-1000 on request

<sup>1)</sup> See Section 8 for extension if bellows or spiral spring is fitted

## SIFA-S, monitoring

### Visual

#### Monitoring

Wear should be checked and documented at regular intervals. This allows the fitting operation for replacement to be planned in good time so as to avoid system downtime.

**OK**  
Wear still <25% of P

**CAUTION!**  
max. permissible wear reached –  
Replace the gearbox

**STOP!**  
Wear >25% or thread already worn through –  
Stop operation immediately!

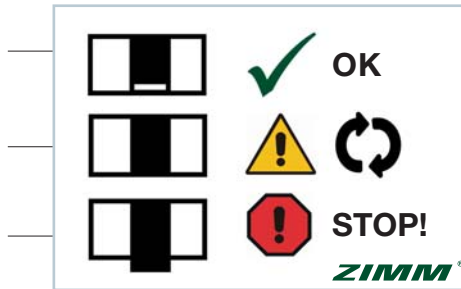

### Electrical

**WARNING! Switch S1**  
At 25% wear the limit switch S1 trips. The customer must detect this signal. This enables substitution to be planned well in advance and therefore prevents any unnecessary downtime.



**STOP! Switch S2**  
If after the first signal operation of the jack continues, the nut will continue to wear until the thread is worn through. When the thread is worn through, the safety nut takes the load. The limit switch S2 trips. The customer must detect this signal and stop the system.

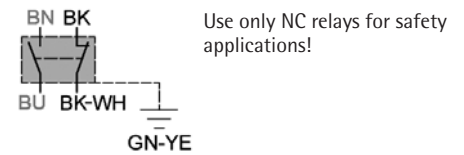
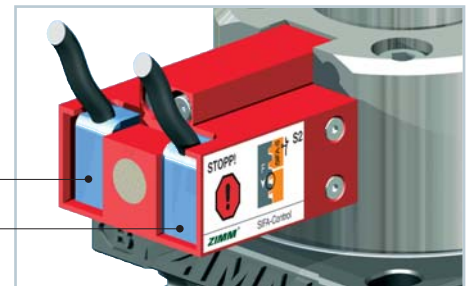

### Without any monitoring

If the version used has no monitoring, the dimension A must be measured and documented when new, then regularly checked and documented.

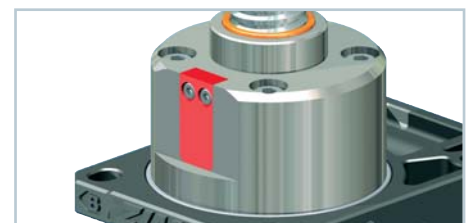
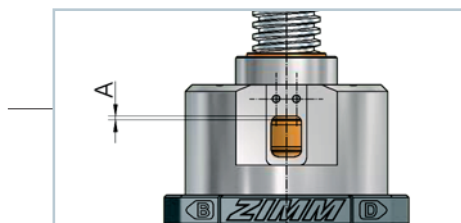



SIFA-R rotating screw

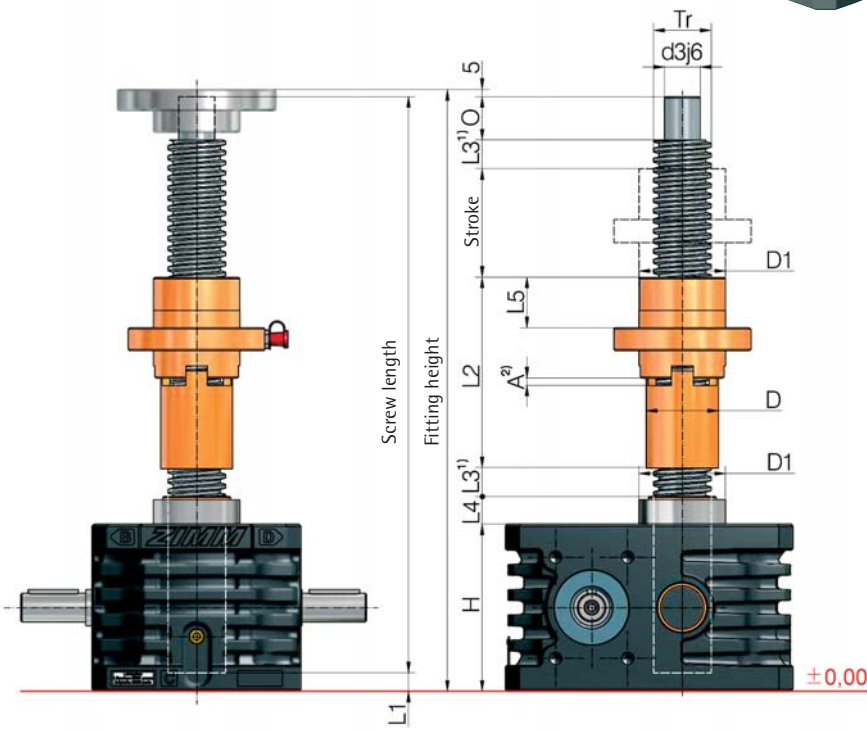
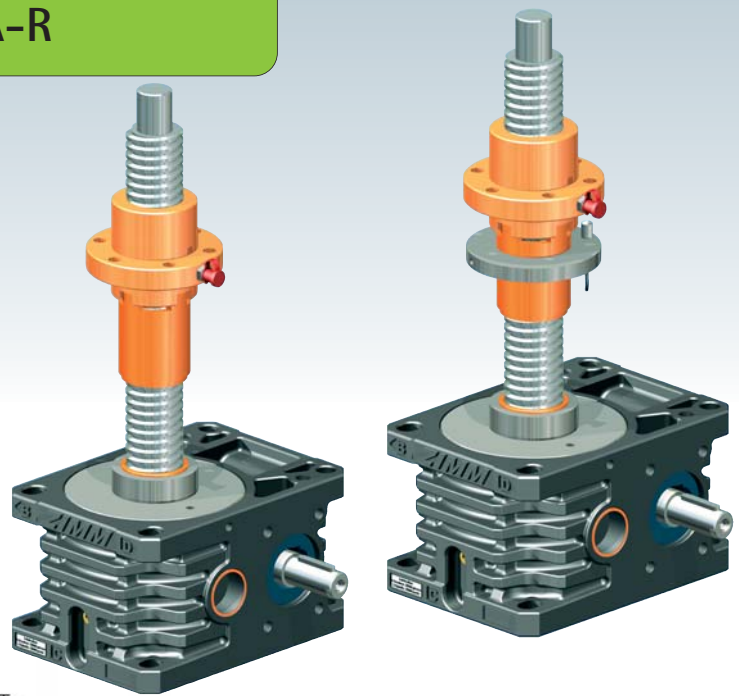

Function R version



The load is borne by the duplex nut. The safety nut runs alongside the duplex nut, bearing no load. If the nut thread is worn through due to wear, the SIFA takes the load.

Direction of loading, tensile or compressive  
A drawing showing the direction of loading is necessary in order to ensure the safety function. The SIFA-R operates in only one direction of loading.

- further technical information: Page 51
- see the respective screw jack page for all other dimensions
- see Section 4 for accessories
- SIFA in combination with self-aligning nut PM available on request

Screw jacks	Tr thread	H	D1	D	d3j6	O	L1	L2	L3 <sup>1)</sup>	L4	L5	A <sup>2)</sup>
Z-5	18x4	62	29	24	12	15	8	70	10	12	20	3
Z-10	20x4	74	39	28	15	20	8	84	10	16	20	3
Z-25	30x6	82	46	38	20	25	5	95	10	17	23	4
Z-35	40x7	100	60	50	25	30	7	133	10	19	36	4
Z-50	40x7	116	60	50	25	30	7	133	10	19	36	4
Z-100	55x9	160	85	65	40	45	8	173	20	30	54	6
Z-150	60x9	185	90	70	45	55	7	211	20	32	75	6
Z-250	80x16	193	120	100	60	75	5	250	20	37	85	9
Z-350	100x16	230	150	120	80	100	6	270	20	24	100	9
Z-500	120x16	260	170	135	95	120	6	303	40	32	110	9
Z-750	140x20	310	200	170	100	120	10	365	40	37	140	12
Z-1000	160x20	340	250	190	130	175	13	500	40	32	210	12

<sup>1)</sup> see Section 8 for extension if bellows or spiral spring is fitted  
<sup>2)</sup> approx. original setting, must be measured and documented by the customer, and referred to when checking

Make sure you fit it the right way up:

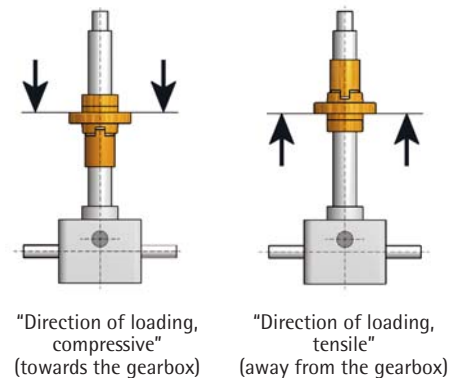



## SIFA-R, monitoring

### Visual

Dimension A is approx. the original setting. Dimension A must be measured and documented by the customer, and referred to when checking.

This enables substitution to be planned well in advance and therefore prevents any unnecessary downtime. When the thread is worn through, take the equipment out of service immediately.

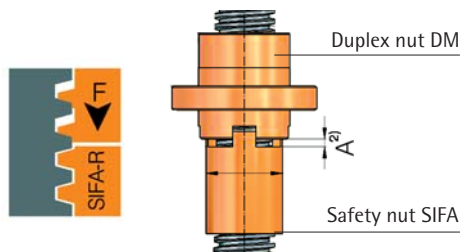

### Electrical

The initiator must be set that it switches off when the load nut reaches 25% of the wear. This enables a replacement to be planned well in advance and therefore prevents any unnecessary downtime. When the thread is worn through, take the system out of service immediately.

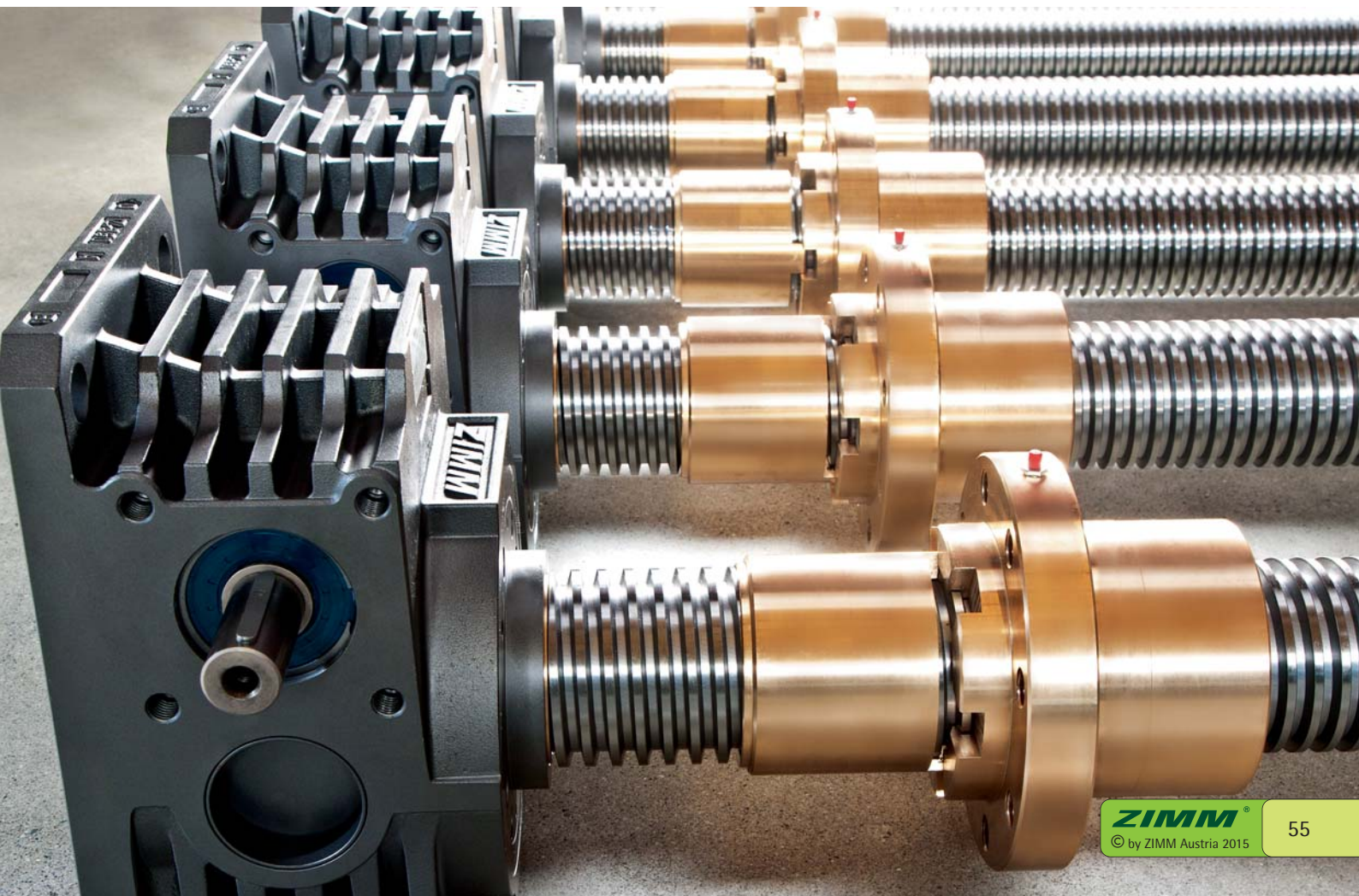
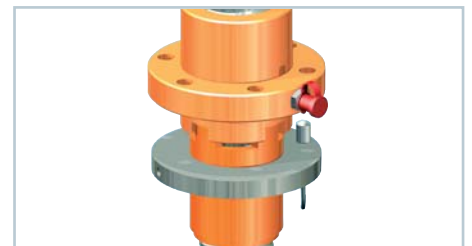
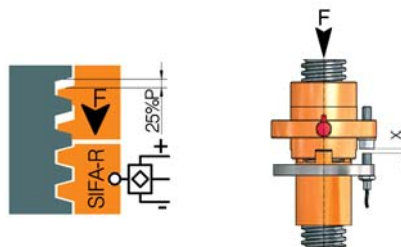

# GSZ series

GSZ series screw jacks are designed for applications where smooth surfaces are required. These screw jacks are easier to clean and therefore ideal for applications in the food processing industry.

Smooth surface

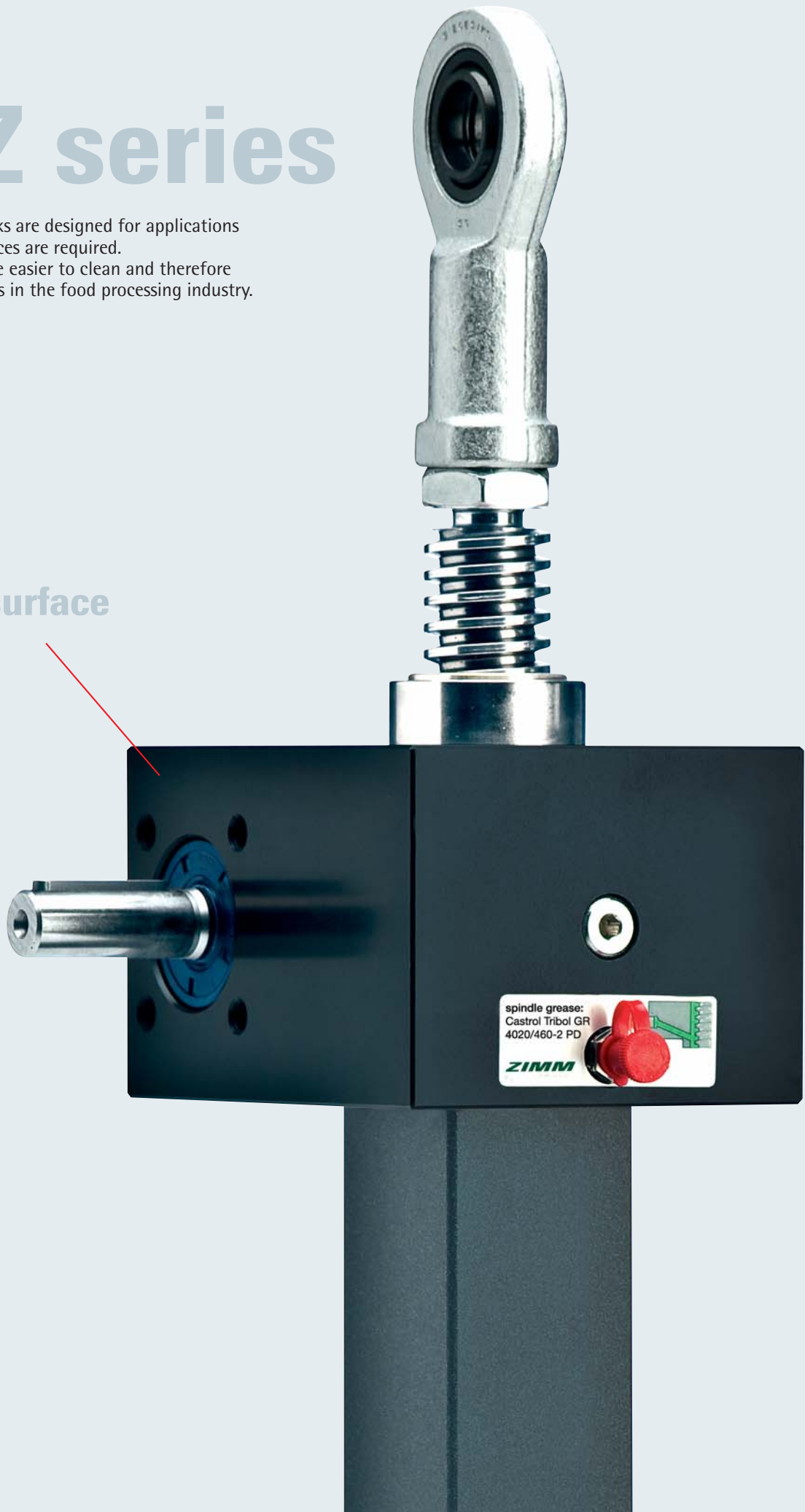

## Types and sizes

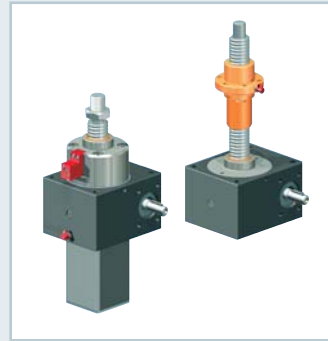
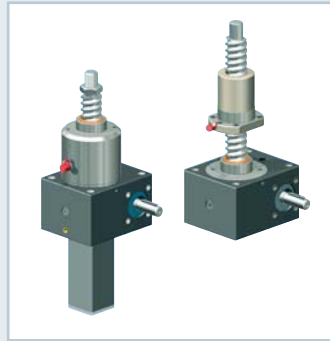
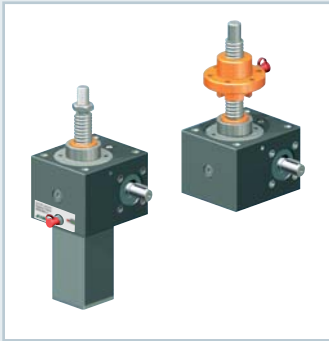

GSZ series jacks Tr  
Trapezoidal screw  
2.5 kN to 100 kN

Pages 58 - 69



GSZ series jacks KGT  
Ball screw  
2.5 kN to 100 kN

Pages 70 - 73



GSZ series jacks SIFA  
Safety nut  
2.5 kN to 100 kN

Pages 74 - 79



We have patents registered or pending for a range of functions and components.



UNIQUE:  
Screw lubrication  
during operation

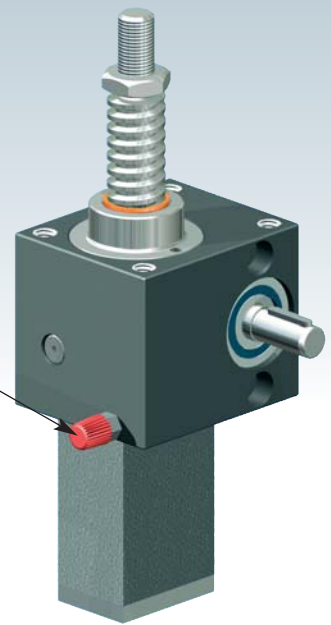

GSZ-2-S translating screw 2.5 kN

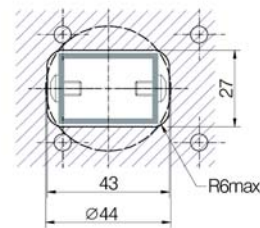
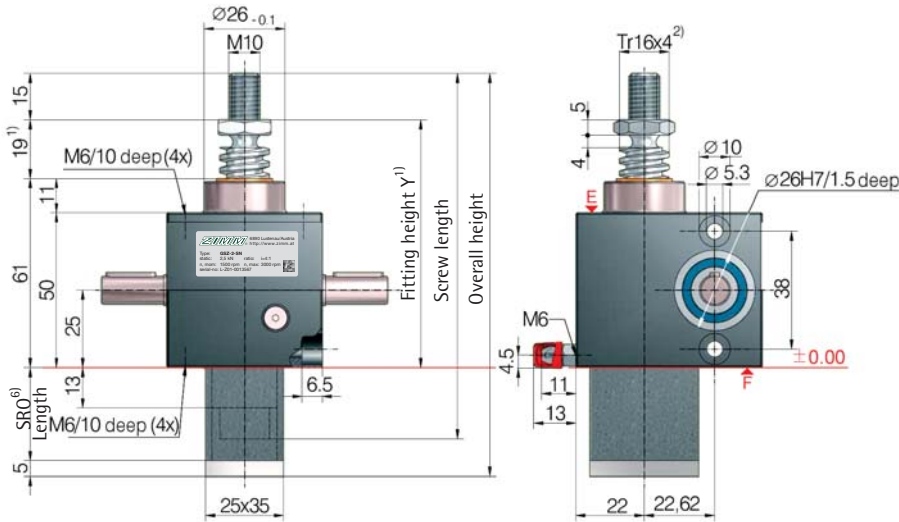

Opening for protective tube SRO, rectangular 43x27 or round Ø 44

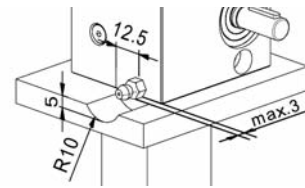

Minimum space requirement for greasing the screw (grease gun)

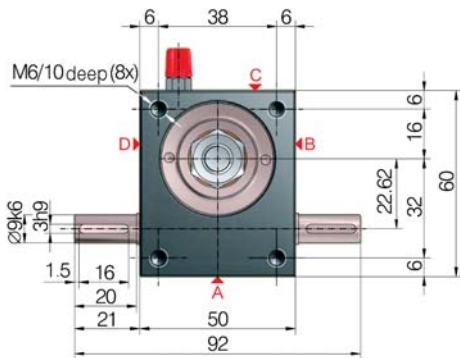

1) Fitting height "Y" for 0-stroke, with Tr 16x4 screw

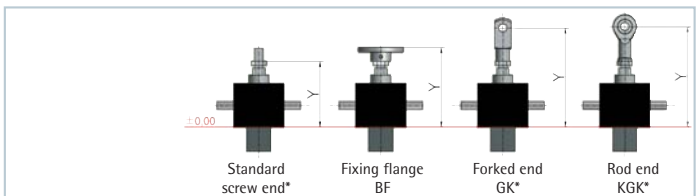

All dimensions in mm

Bellocs FB	Y	Y	Y	Y
without bellocs FB	80	96	120	123
GSZ-2-FB-182	117	116	157	160
GSZ-2-FB-364	177	176	217	220

\*with bellocs fixing ring Z-2-FBR

6) Protective tube length SRO with Tr 16x4 screw

Without escape/ rotation protection	Escape/ rotation protection	Rotation protection, with limit switch set ES	Rotation protection with ES and KAR*
47+stroke	62+stroke	117+stroke	139+stroke

\*Hinged bearing plate KAR, fitted on face F (below).

Standard ratios

Type	Version	Speed	Standard screw <sup>2)</sup>	i	Stroke per drive shaft rotation <sup>5)</sup>
GSZ-2-SN	Translating	Normal	Tr 16x4	4:1	1.00 mm
GSZ-2-SL	screw	Low speed		16:1	0.25 mm
GSZ-2-RN	Rotating	Normal	Tr 16x4	4:1	1.00 mm
GSZ-2-RL	screw	Low speed		16:1	0.25 mm

Screw jack mounting

max. load: 2.5 kN compressive and tensile load  
 Screw: M6, strength class 8.8  
 Screw-in depth: 8 to 10 mm  
 Tightening torque: 8 Nm  
 Screw locking: with Loctite 243

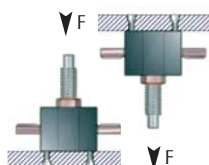

Duty cycle thermal limit, for S+R

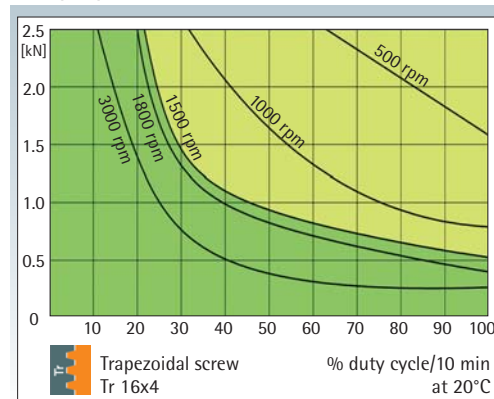

These curves are for guidance under standard industrial conditions (ambient temperature etc.) and correct maintenance (lubrication etc.). The max. input drive torques for optimum service life are at the right page - technical data (1500 rpm)

KGT: % duty cycle 2 times to 4 times higher

Trapezoidal screw

Tr



## GSZ-2-R rotating screw 2.5 kN

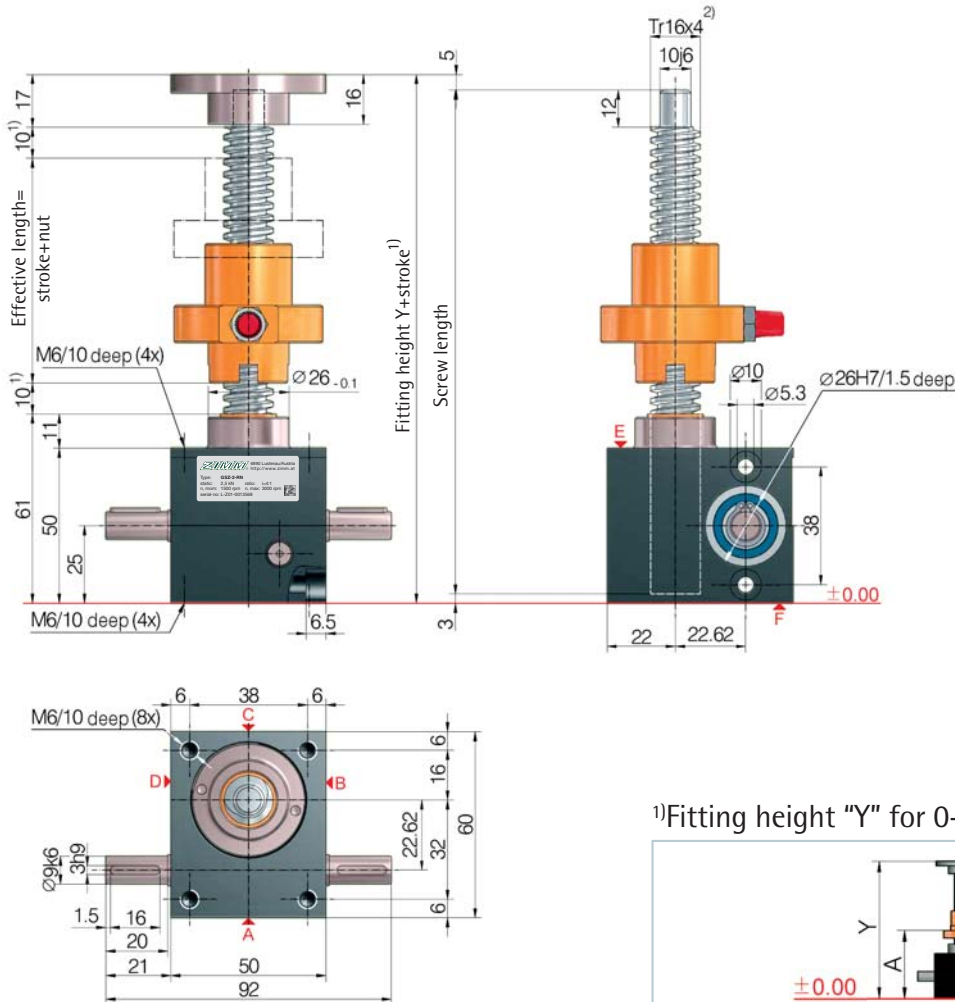
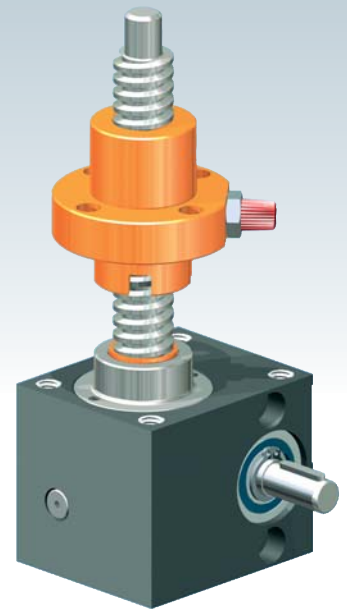

<sup>1)</sup>Fitting height "Y" for 0-stroke, with Tr 16x4 screw

All dimensions in mm	Flange nut FM	Duplex nut DM	Duplex nut DM with SIFA
<b>Bellocs FB</b>	Y/A	Y/A	Y/A
without bellocs FB	132/83	142/96	167/121
2x GSZ-2-FB-182	-	198/124	220/146
2x GSZ-2-FB-364	-	318/184	340/206

Detailed instructions for determining the length can be found in Section 8

# 2.5 kN

## Technical data series GSZ-2-S / GSZ-2-R

max. compressive/tensile force, static	- 2.5 kN (250 kg)
max. compressive/tensile force, dynamic	- see duty cycle curves
Nominal speed	- 1500 rpm
max. drive shaft speed	- 3000 rpm (depending on the load and duty cycle)
Screw size standard	- Tr 16x4 <sup>2)</sup>
Gear ratio	- 4:1 (N) / 16:1 (L)
Housing material	- aluminium, corrosion-resistant
Worm shaft	- stainless steel, ground
Weight of screw jack body	- 0.6 kg
Weight of screw/m	- 1.21 kg
Gearbox lubrication	- synthetic fluid grease
Screw lubrication	- grease lubrication
Gearbox operating temperature	- max. 60°C, higher on request
Moment of inertia	- N: 0.081 kg cm <sup>2</sup> / L: 0.037 kg cm <sup>2</sup>
Input torque (at 1500 rpm)	- max. 1.4 Nm (N) / max. 0.5 Nm (L)
Drive-through torque	- max. 9 Nm

Drive torque $M_G$ (Nm)	- $F$ (kN) $\times$ 0.52 <sup>3)5)</sup> + $M_L$ (N-normal)
Breakaway torque	- $F$ (kN) $\times$ 0.15 <sup>3)5)</sup> + $M_L$ (L-low speed)
Idling torque <sup>4)</sup> $M_L$ (Nm)	- Drive torque $M_G$ $\times$ 1.5
	- 0.08 (N-normal) / 0.06 (L-low speed)

Between gearbox and nut or nut and end of thread, provide for a safety distance of (minimum) 10 mm!

See Section 7 for the checklist.

### Important information

- 1) - extension if a bellows is fitted: see the table or Section 8
- 2) - Tr 16x4 is standard, also available: double-pitch, stainless steel, left-handed, increased screw Tr 18x4 (only for the R version)
- 3) - factor includes efficiency, ratio and 30% safety
- 4) - at 20°C, can be higher when new
- 5) - for a 4 mm screw pitch

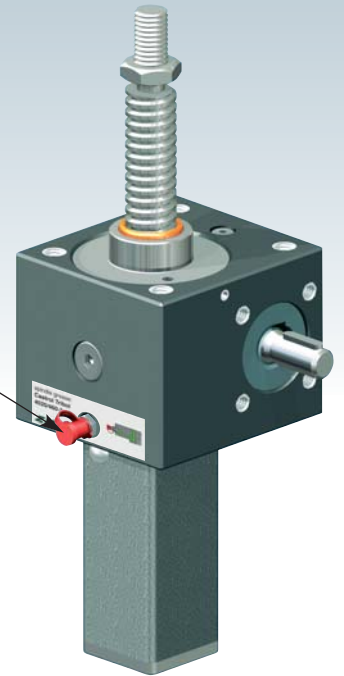

UNIQUE:  
Screw lubrication during operation

GSZ-5-S translating screw 5 kN

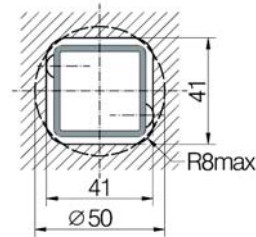
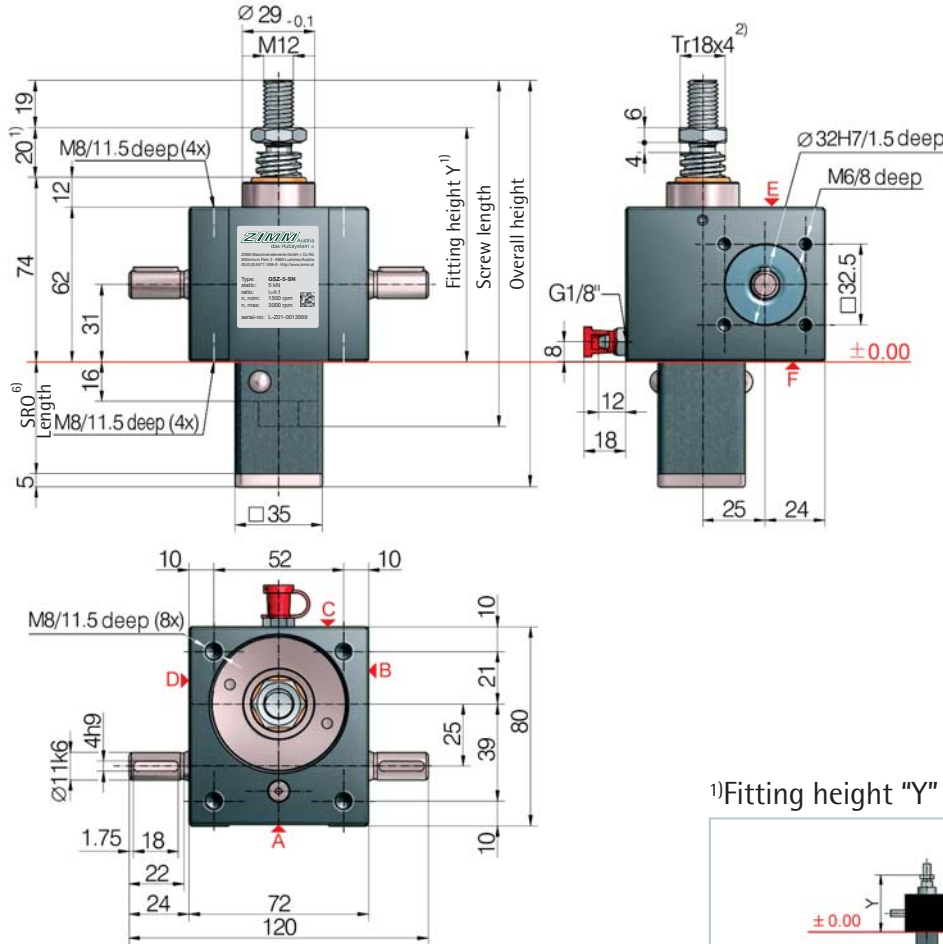

<sup>1)</sup>Fitting height "Y" for 0-stroke, with Tr 18x4 screw

	Standard screw end*	Fixing flange BF	Forked end GK*	Rod end KGK*	Pivot bearing end SLK
All dimensions in mm	Y	Y	Y	Y	Y
Bellocs FB	Y	Y	Y	Y	Y
without bellocs FB	94	114	142	144	142
Z-5-FB-265	127	127	175	177	155
Z-5-FB-500	192	192	240	242	220
Z-5-FB-800	212	212	260	262	240

<sup>6)</sup>Protective tube length SRO with Tr 18x4 screw

Without escape/rotation protection	Escape/rotation protection	Rotation protection, with limit switch set ES	Rotation protection with ES and KAR*
46+stroke	61+stroke	119+stroke	140+stroke

\*Hinged bearing plate KAR, fitted on face F (below).

Standard ratios

Type	Version	Speed	Standard screw <sup>2)</sup>	i	Stroke per drive shaft rotation <sup>5)</sup>
GSZ-5-SN	Translating	Normal	Tr 18x4	4:1	1.00 mm
GSZ-5-SL	screw	Low speed		16:1	0.25 mm
GSZ-5-RN	Rotating	Normal	Tr 18x4	4:1	1.00 mm
GSZ-5-RL	screw	Low speed		16:1	0.25 mm

Screw jack mounting

- max. load: 5 kN compressive and tensile load
- Screw: M8, strength class 8.8
- Screw-in depth: 10 to 11.5 mm
- Tightening torque: 19 Nm
- Screw locking: with Loctite 243

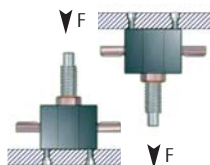

Duty cycle thermal limit, for S+R

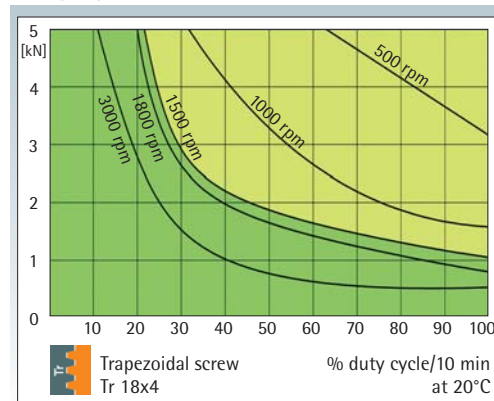

These curves are for guidance under standard industrial conditions (ambient temperature etc.) and correct maintenance (lubrication etc.). The max. input drive torques for optimum service life are at the right page - technical data (1500 rpm)

KGK: % duty cycle 2 times to 4 times higher

Trapezoidal screw

Tr



## GSZ-5-R rotating screw 5 kN

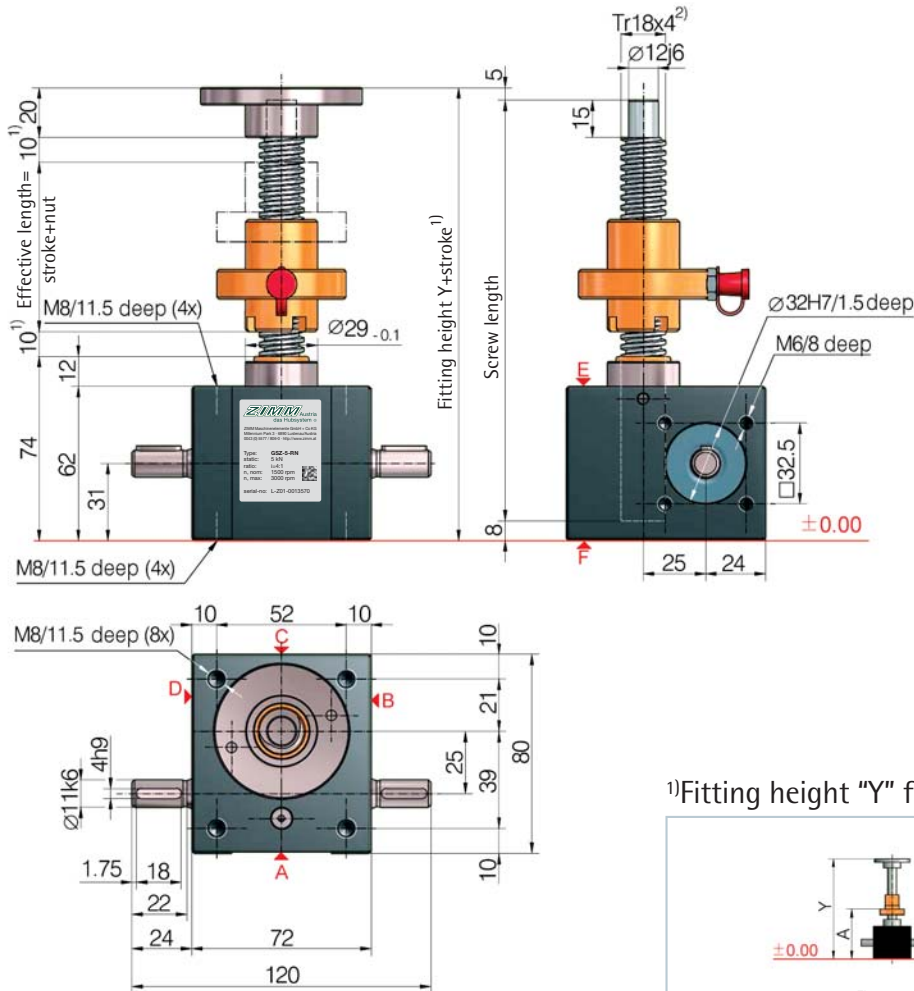
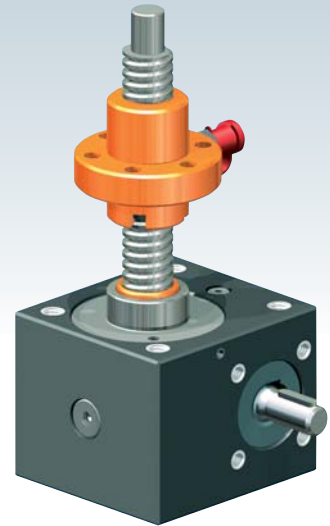

<sup>1)</sup>Fitting height "Y" for 0-stroke, with Tr 18x4 screw

All dimensions in mm	Flange nut FM	Duplex nut DM	Duplex nut DM with SIFA	Self-aligning nut PM	Greasless nut FFDM
<b>Bellows FB</b>	Y/A	Y/A	Y/A	Y/A	Y/A
without bellows FB	149/96	159/109	184/134	192/141	167/117
2x Z-5-FB-265	-	207/132	229/154	240/164	215/140
2x Z-5-FB-500	-	337/197	359/219	370/229	345/205
2x Z-5-FB-800	-	377/217	399/239	410/249	385/225

Detailed instructions for determining the length can be found in Section 8

# 5 kN

## Technical data series GSZ-5-S / GSZ-5-R

max. compressive/tensile force, static	- 5 kN (500 kg)
max. compressive/tensile force, dynamic	- see duty cycle curves
Nominal speed	- 1500 rpm
max. drive shaft speed	- 3000 rpm (depending on the load and duty cycle)
Screw size standard	- Tr 18x4 <sup>2)</sup>
Gear ratio	- 4:1 (N) / 16:1 (L)
Housing material	- aluminium, corrosion-resistant
Worm shaft	- steel, case-hardened, ground
Weight of screw jack body	- 1.2 kg
Weight of screw/m	- 1.58 kg
Gearbox lubrication	- synthetic fluid grease
Screw lubrication	- grease lubrication
Gearbox operating temperature	- max. 60°C, higher on request
Moment of inertia	- N: 0.217 kg cm <sup>2</sup> / L: 0.117 kg cm <sup>2</sup>
Input torque (at 1500 rpm)	- max. 4.7 Nm (N) / max. 1.5 Nm (L)
Drive-through torque	- max. 39 Nm

Drive torque $M_G$ (Nm)	- $F$ (kN) $\times$ 0.62 <sup>3)5)</sup> + $M_L$ (N-normal)
Breakaway torque	- $F$ (kN) $\times$ 0.21 <sup>3)5)</sup> + $M_L$ (L-low speed)
Idling torque <sup>4)</sup> $M_L$ (Nm)	- Drive torque $M_G$ $\times$ 1.5
	- 0.10 (N-normal) / 0.08 (L-low speed)

Between gearbox and nut or nut and end of thread, provide for a safety distance of (minimum) 10 mm!  
See Section 7 for the checklist.

## Important information

- 1) - extension if a bellows or spiral spring is fitted: see the table or Section 8
- 2) - Tr 18x4 is standard, also available: double-pitch, stainless steel, left-handed, increased screw Tr 20x4 (only for the R version)
- 3) - factor includes efficiency, ratio and 30% safety
- 4) - at 20°C, can be higher when new
- 5) - for a 4 mm screw pitch



UNIQUE:  
Screw lubrication  
during operation

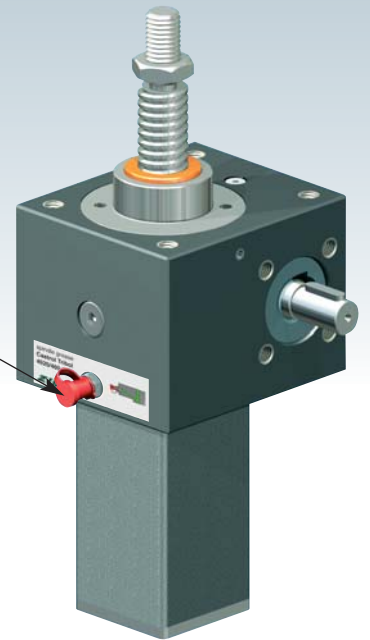

GSZ-10-S translating screw 10 kN

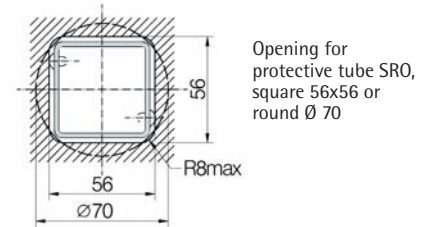
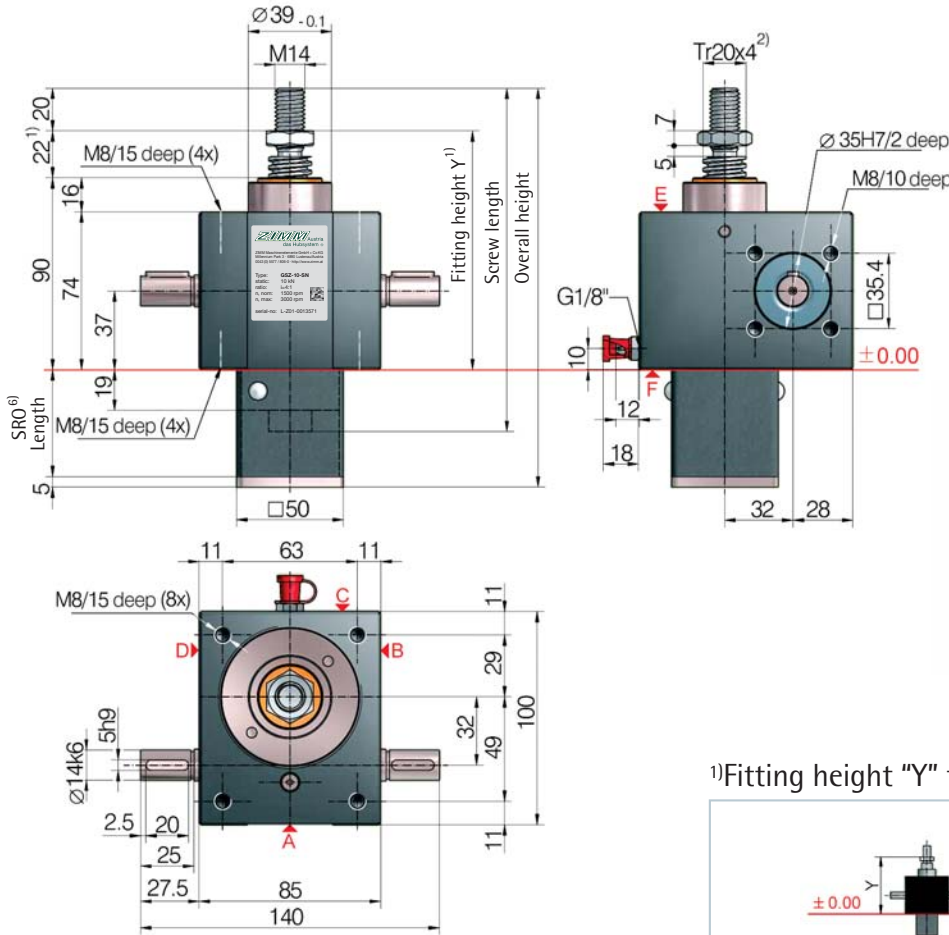

1) Fitting height "Y" for 0-stroke, with Tr 20x4 screw

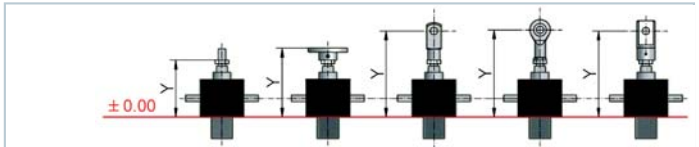

All dimensions in mm

Bellocs FB	Y	Y	Y	Y	Y
without bellocs FB	112	133	168	173	168
Z-10-FB-340	193	189	249	254	224
Z-10-FB-700	213	209	269	274	244
Z-10-FB-1000	263	259	319	324	294

6) Protective tube length SRO with Tr 20x4 screw

Without escape/ rotation protection	Escape/ rotation protection	Rotation protection, with limit switch set ES	Rotation protection with ES and KAR*
49+stroke	69+stroke	121+stroke	141+stroke

\*Hinged bearing plate KAR, fitted on face F (below).

\*with bellocs fixing ring Z-10-FBR

Standard ratios

Type	Version	Speed	Standard screw <sup>2)</sup>	i	Stroke per drive shaft rotation <sup>5)</sup>
GSZ-10-SN	Translating	Normal	Tr 20x4	4:1	1.00 mm
GSZ-10-SL	screw	Low speed		16:1	0.25 mm
GSZ-10-RN	Rotating	Normal	Tr 20x4	4:1	1.00 mm
GSZ-10-RL	screw	Low speed		16:1	0.25 mm

Screw jack mounting

- max. load: 10 kN compressive and tensile load
- Screw: M8, strength class 8.8
- Screw-in depth: 10 to 15 mm
- Tightening torque: 17 Nm
- Screw locking: with Loctite 243

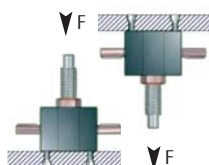

Duty cycle thermal limit, for S+R

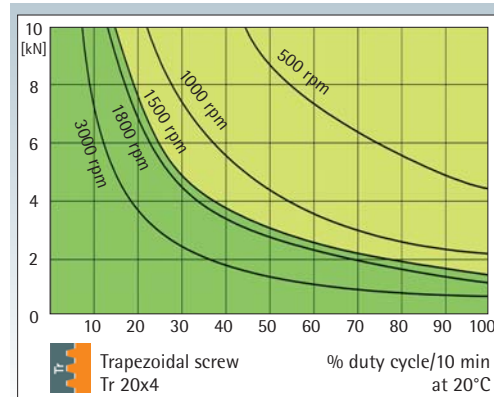

These curves are for guidance under standard industrial conditions (ambient temperature etc.) and correct maintenance (lubrication etc.). The max. input drive torques for optimum service life are at the right page - technical data (1500 rpm)

KGK: % duty cycle 2 times to 4 times higher





## GSZ-10-R rotating screw 10 kN

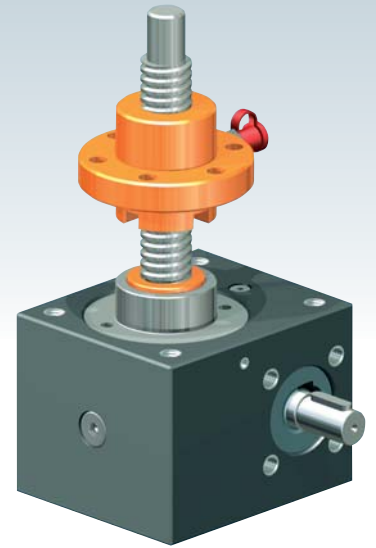
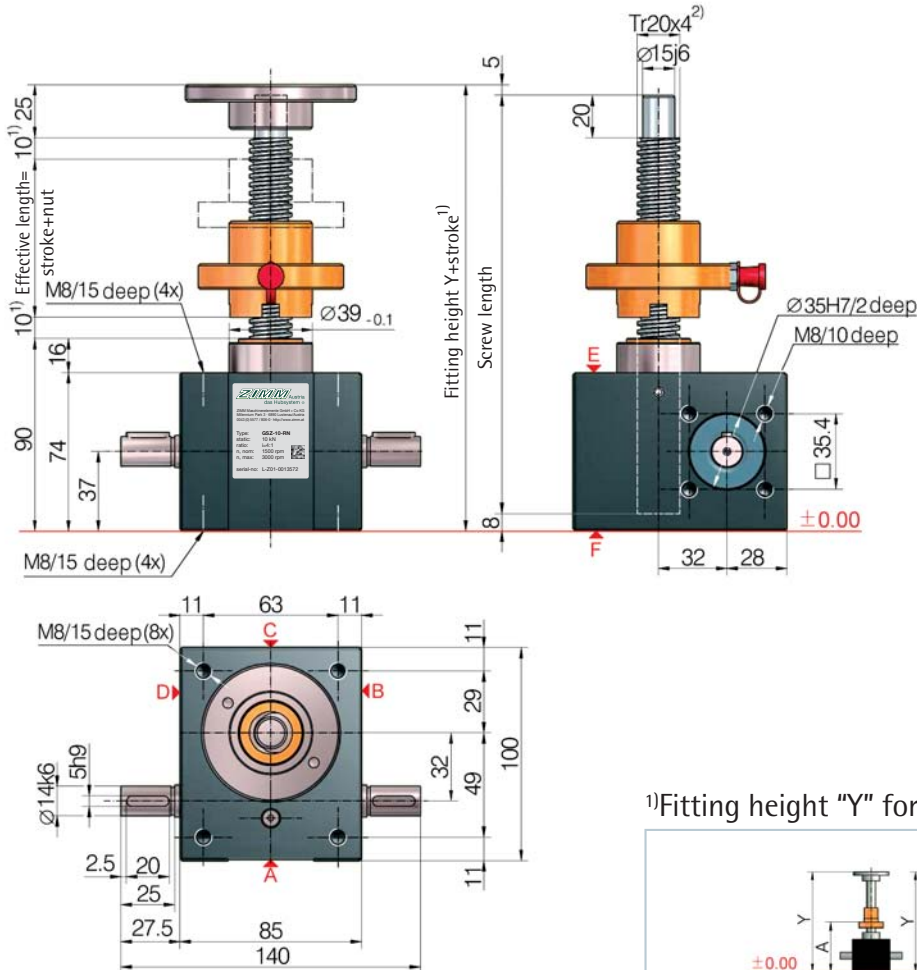

<sup>1)</sup>Fitting height "Y" for 0-stroke, with Tr 20x4 screw

All dimensions in mm	Flange nut FM	Duplex nut DM	Duplex nut DM with SIFA	Self-aligning nut PM	Greasless nut FFDM
<b>Bellows FB</b>	Y/A	Y/A	Y/A	Y/A	Y/A
without bellows FB	179/112	180/125	219/164	218/159	188/133
2x Z-10-FB-340	-	314/193	350/229	352/227	322/201
2x Z-10-FB-700	-	354/213	390/249	392/247	362/221
2x Z-10-FB-1000	-	454/263	490/299	492/297	462/271

Detailed instructions for determining the length can be found in Section 8

# 10 kN

### Technical data series GSZ-10-S / GSZ-10-R

max. compressive/tensile force, static	- 10 kN (1 t)
max. compressive/tensile force, dynamic	- see duty cycle curves
Nominal speed	- 1500 rpm
max. drive shaft speed	- 3000 rpm (depending on the load and duty cycle)
Screw size standard	- Tr 20x4 <sup>2)</sup>
Gear ratio	- 4:1 (N) / 16:1 (L)
Housing material	- aluminium, corrosion-resistant
Worm shaft	- steel, case-hardened, ground
Weight of screw jack body	- 2.1 kg
Weight of screw/m	- 2 kg
Gearbox lubrication	- synthetic fluid grease
Screw lubrication	- grease lubrication
Gearbox operating temperature	- max. 60°C, higher on request
Moment of inertia	- N: 0.641 kg cm <sup>2</sup> / L: 0.271 kg cm <sup>2</sup>
Input torque (at 1500 rpm)	- max. 13.5 Nm (N) / max. 7.5 Nm (L)
Drive-through torque	- max. 57 Nm

Drive torque $M_G$ (Nm)	- $F$ (kN) $\times$ 0.64 <sup>3)</sup> + $M_L$ (N-normal) - $F$ (kN) $\times$ 0.20 <sup>3)</sup> + $M_L$ (L-low speed)
Breakaway torque	- Drive torque $M_G \times 1.5$
Idling torque <sup>4)</sup> $M_L$ (Nm)	- 0.26 (N-normal) / 0.16 (L-low speed)

Between gearbox and nut or nut and end of thread, provide for a safety distance of (minimum) 10 mm!  
See Section 7 for the checklist.

#### Important information

- extension if a bellows or spiral spring is fitted: see the table or Section 8
- Tr 20x4 is standard, also available: double-pitch, stainless steel, left-handed, increased screw Tr 30x6 (only for the R version)
- factor includes efficiency, ratio and 30% safety
- at 20°C, can be higher when new
- for a 4 mm screw pitch



UNIQUE:  
Screw lubrication  
during operation

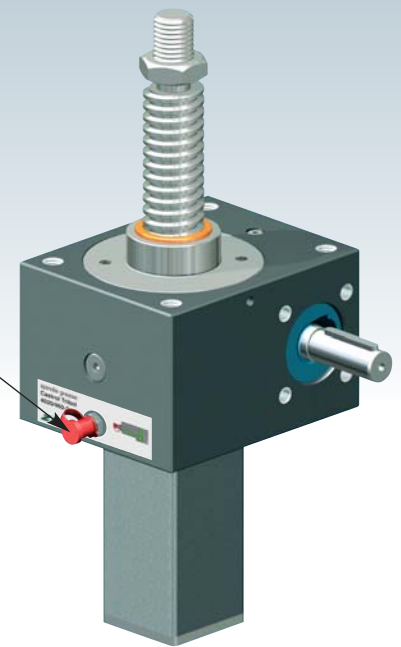

GSZ-25-S translating screw 25 kN

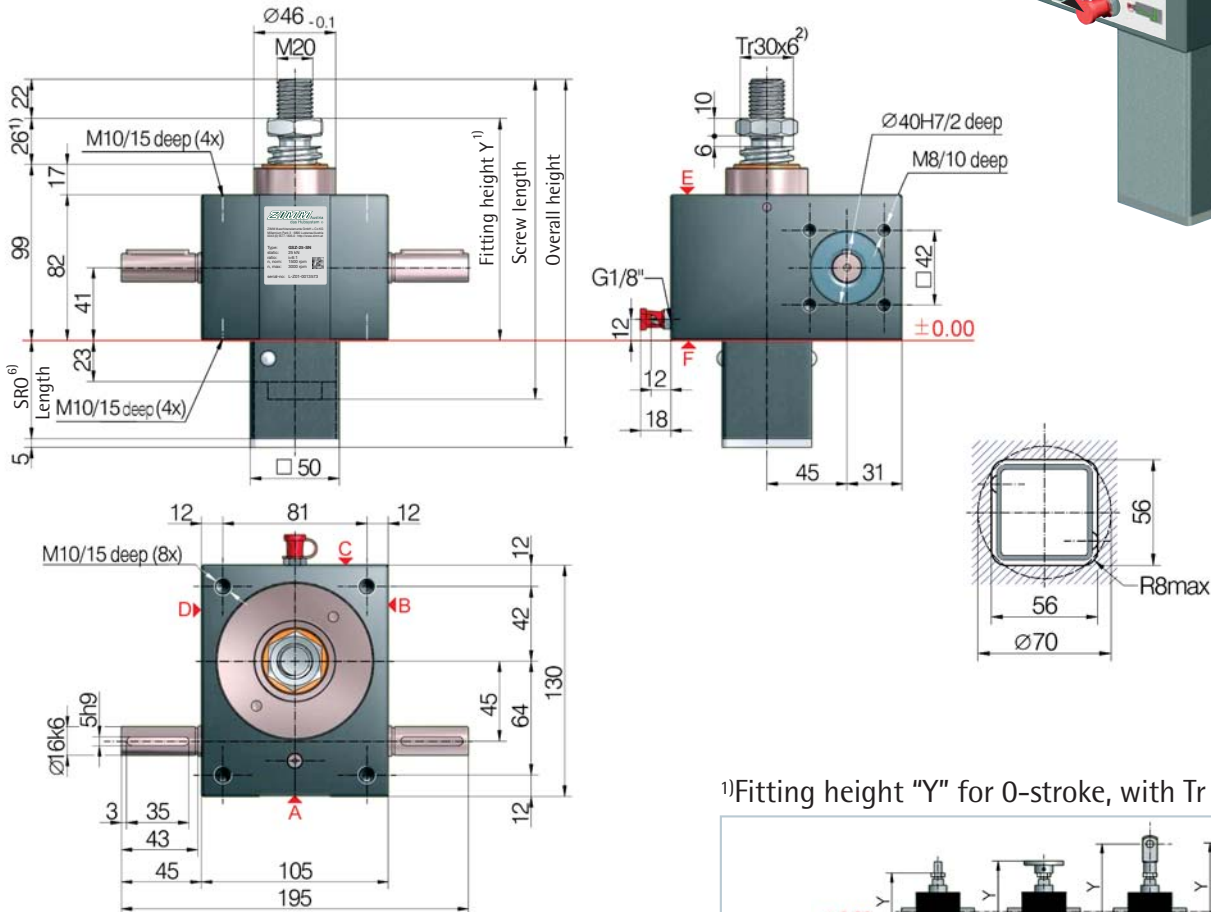

Opening for protective tube SR0, square 56x56 or round Ø 70

<sup>1)</sup>Fitting height "Y" for 0-stroke, with Tr 30x6 screw

Bellocs FB	Y	Y	Y	Y	Y
without bellocs FB	125	148	205	202	205
Z-25-FB-300	200	192	280	277	249
Z-25-FB-700	230	222	310	307	279
Z-25-FB-1000	250	242	330	327	299

<sup>6)</sup>Protective tube length SR0 with Tr 30x6 screw

Without escape/ rotation protection	Escape/ rotation protection	Rotation protection, with limit switch set ES	Rotation protection with ES and KAR*
53+stroke	73+stroke	125+stroke	149+stroke

\*Hinged bearing plate KAR, fitted on face F (below).

Standard ratios

Type	Version	Speed	Standard screw <sup>2)</sup>	i	Stroke per drive shaft rotation <sup>5)</sup>
GSZ-25-SN	Translating	Normal	Tr 30x6	6:1	1.00 mm
GSZ-25-SL	screw	Low speed		24:1	0.25 mm
GSZ-25-RN	Rotating	Normal	Tr 30x6	6:1	1.00 mm
GSZ-25-RL	screw	Low speed		24:1	0.25 mm

Screw jack mounting

max. load: 25 kN compressive and tensile load  
Screw: M10, strength class 8.8  
Screw-in depth: 12 to 15 mm  
Tightening torque: 27 Nm  
Screw locking: with Loctite 243

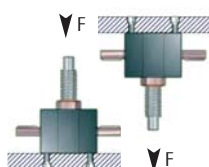

Duty cycle thermal limit, for S+R

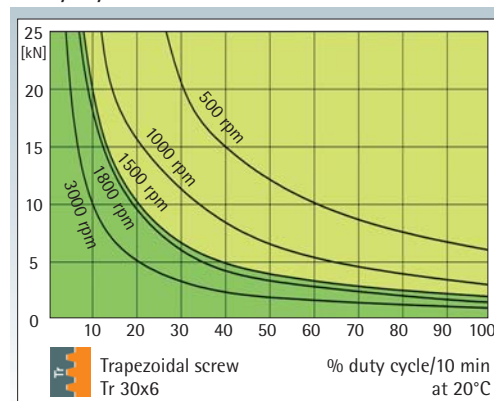

These curves are for guidance under standard industrial conditions (ambient temperature etc.) and correct maintenance (lubrication etc.). The max. input drive torques for optimum service life are at the right page - technical data (1500 rpm)

KGT:  
% duty cycle  
2 times to  
4 times higher

Trapezoidal screw

Tr



## GSZ-25-R rotating screw 25 kN

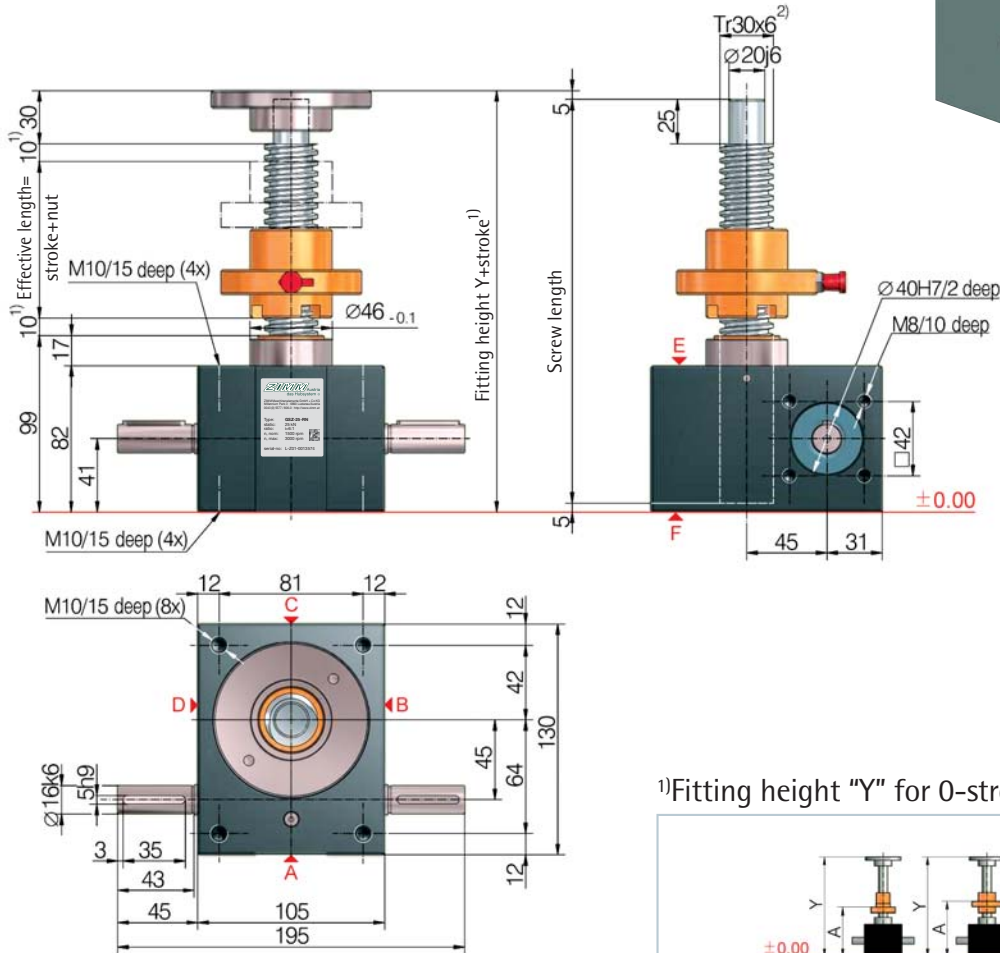
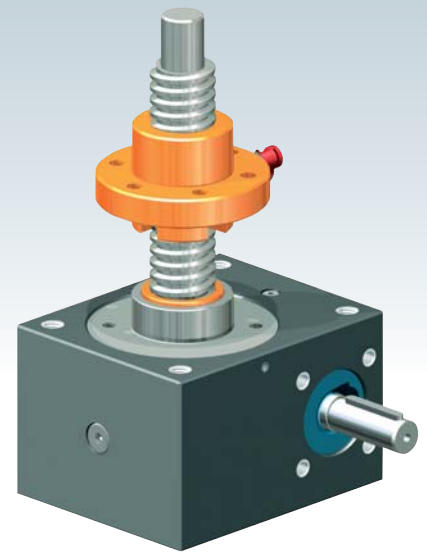

1) Fitting height "Y" for 0-stroke, with Tr 30x6 screw

All dimensions in mm	Flange nut FM	Duplex nut DM	Duplex nut DM with SIFA	Self-aligning nut PM	Greasless nut FFDM
<b>Bellows FB</b>	Y/A	Y/A	Y/A	Y/A	Y/A
without bellows FB	195/123	199/136	244/181	244/177	208/145
2x Z-25-FB-300	-	314/196	353/235	359/237	325/207
2x Z-25-FB-700	-	374/226	413/265	419/267	385/237
2x Z-25-FB-1000	-	414/246	453/285	459/287	425/257

Detailed instructions for determining the length can be found in Section 8

# 25 kN

## Technical data series GSZ-25-S / GSZ-25-R

max. compressive/tensile force, static	- 25 kN (2.5 t)
max. compressive/tensile force, dynamic	- see duty cycle curves
Nominal speed	- 1500 rpm
max. drive shaft speed	- 3000 rpm (depending on the load and duty cycle)
Screw size standard	- Tr 30x6 <sup>2)</sup>
Gear ratio	- 6:1 (N) / 24:1 (L)
Housing material	- aluminium, corrosion-resistant
Worm shaft	- steel, case-hardened, ground
Weight of screw jack body	- 3.8 kg
Weight of screw/m	- 4.5 kg
Gearbox lubrication	- synthetic fluid grease
Screw lubrication	- grease lubrication
Gearbox operating temperature	- max. 60°C, higher on request
Moment of inertia	- N: 1.449 kg cm <sup>2</sup> / L: 0.589 kg cm <sup>2</sup>
Input torque (at 1500 rpm)	- max. 18 Nm (N) / max. 10 Nm (L)
Drive-through torque	- max. 108 Nm

Drive torque $M_G$ (Nm)	- F (kN) x 0.63 <sup>3)</sup> (N-normal)
	- F (kN) x 0.20 <sup>3)</sup> (L-low speed)
Breakaway torque	- Drive torque $M_G$ x 1.5
Idling torque <sup>4)</sup> $M_L$ (Nm)	- 0.36 (N-normal) / 0.26 (L-low speed)

Between gearbox and nut or nut and end of thread, provide for a safety distance of (minimum) 10 mm!

See Section 7 for the checklist.

### Important information

- 1) - extension if a bellows or spiral spring is fitted: see the table or Section 8
- 2) - Tr 30x6 is standard, also available: double-pitch, stainless steel, left-handed, increased screw Tr 40x7 (only for the R version)
- 3) - factor includes efficiency, ratio and 30% safety
- 4) - at 20°C, can be higher when new
- 5) - for a 6 mm screw pitch

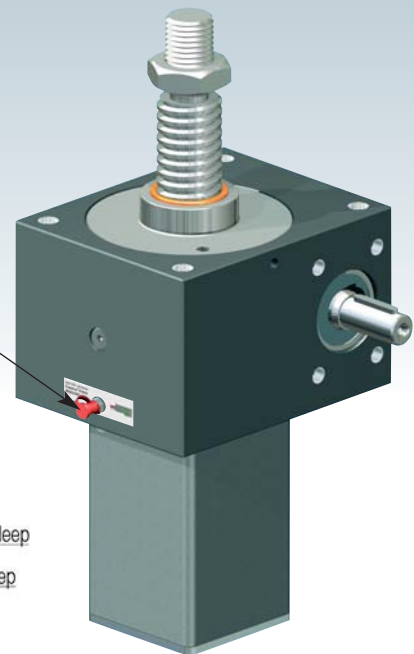

UNIQUE:  
Screw lubrication  
during operation

GSZ-50-S translating screw 50 kN

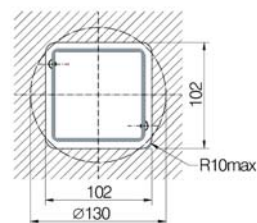
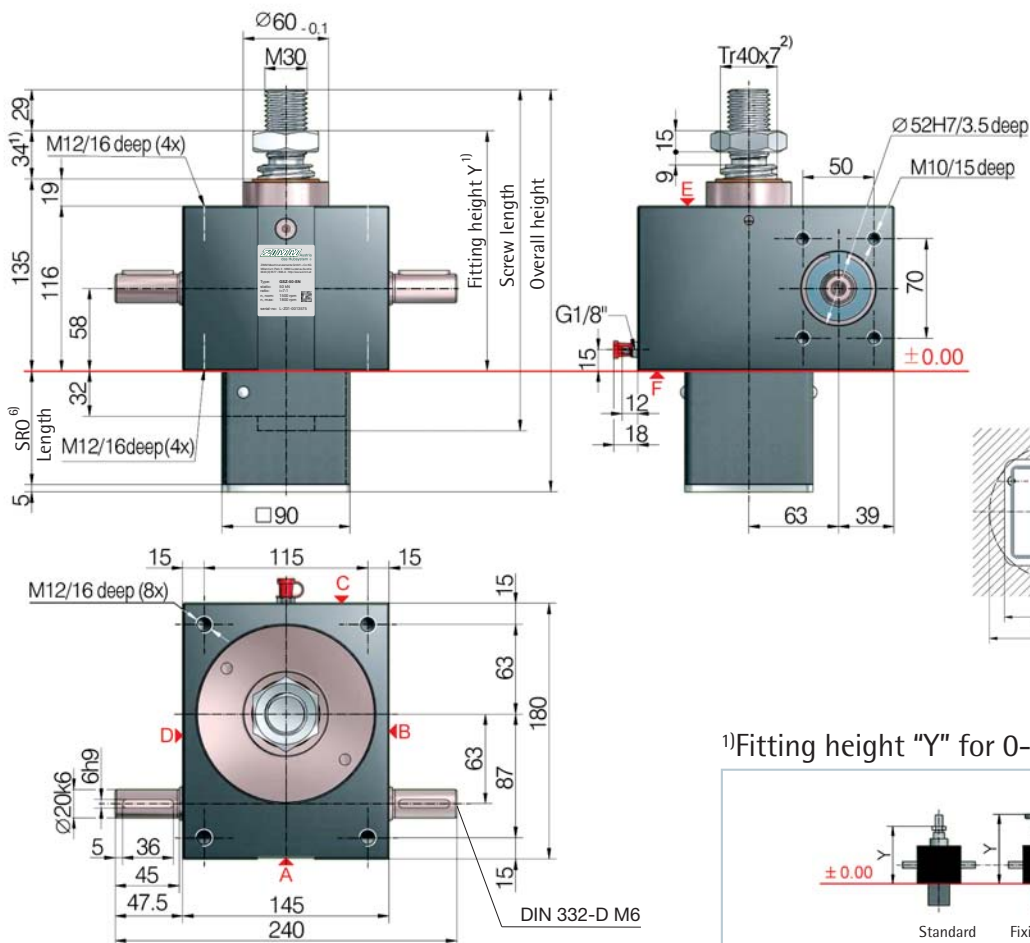

6) Protective tube length SRO with Tr 40x7 screw

Without escape/ rotation protection	Escape/ rotation protection	Rotation protection, with limit switch set ES	Rotation protection with ES and KAR*
62+stroke	92+stroke	144+stroke	169+stroke

\*Hinged bearing plate KAR, fitted on face F (below).

1) Fitting height "Y" for 0-stroke, with Tr 40x7 screw

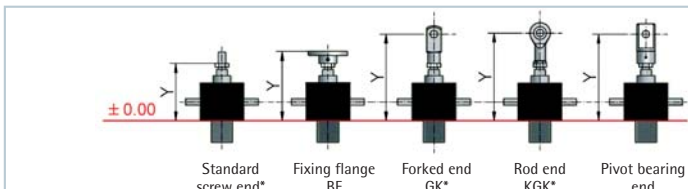

All dimensions in mm

Bellocs FB	Y	Y	Y	Y	Y
without bellocs FB	169	199	289	279	261
Z-50-FB-390	264	248	384	374	310
Z-50-FB-600	251	235	371	361	297
Z-50-FB-1000	309	293	429	419	355
Z-50-FB-1200	304	288	424	414	350
Z-50-FB-1500	359	343	479	469	405

\*with bellocs fixing ring Z-50-FBR

Standard ratios

Type	Version	Speed	Standard screw <sup>2)</sup>	i	Stroke per drive shaft rotation <sup>5)</sup>
GSZ-50-SN	Translating	Normal	Tr 40x7	7:1	1.00 mm
GSZ-50-SL	screw	Low speed		28:1	0.25 mm
GSZ-50-RN	Rotating	Normal	Tr 40x7	7:1	1.00 mm
GSZ-50-RL	screw	Low speed		28:1	0.25 mm

Screw jack mounting

max. load: 50 kN compressive and tensile load  
Screw: M12, strength class 8.8  
Screw-in depth: 12 to 17 mm  
Tightening torque: 38 Nm  
Screw locking: with Loctite 243

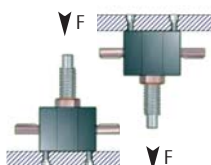

Duty cycle thermal limit, for S+R

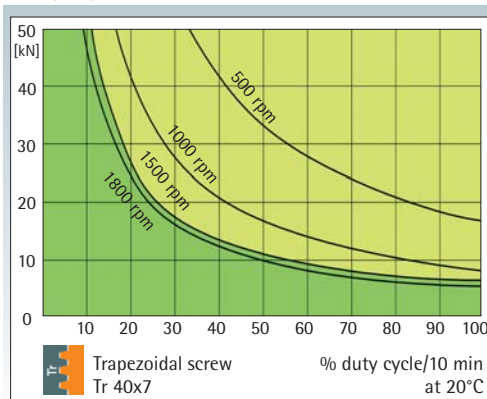

These curves are for guidance under standard industrial conditions (ambient temperature etc.) and correct maintenance (lubrication etc.). The max. input drive torques for optimum service life are at the right page - technical data (1500 rpm)

KGT:  
% duty cycle  
2 times to  
4 times higher

Trapezoidal screw

Tr



## GSZ-50-R rotating screw 50 kN

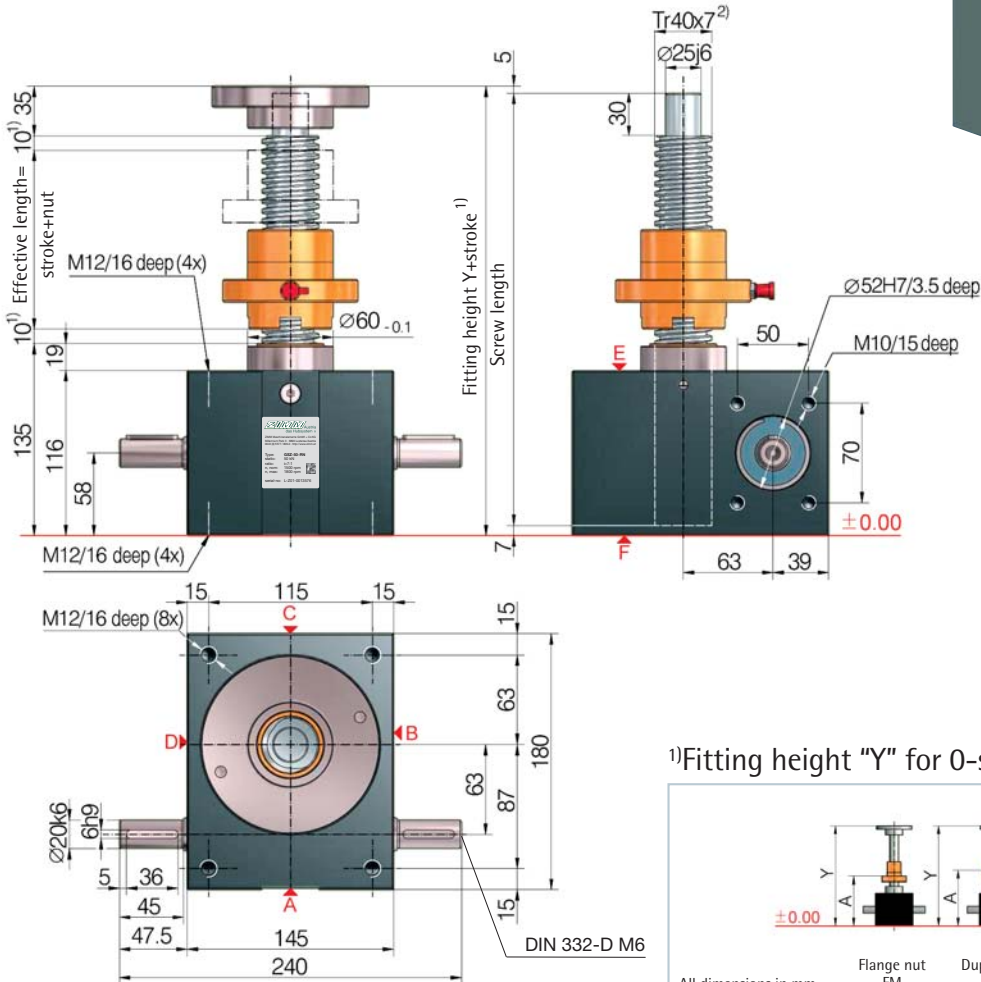
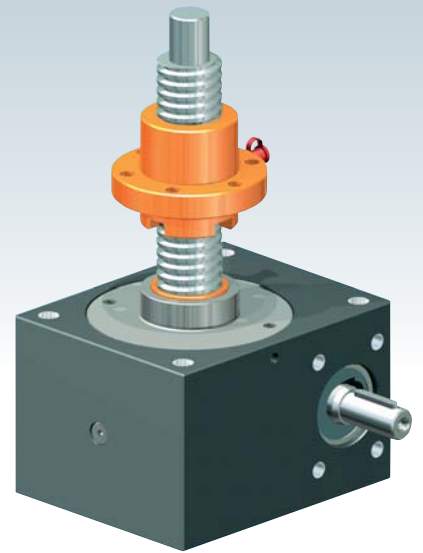

<sup>1)</sup>Fitting height "Y" for 0-stroke, with Tr 40x7 screw

All dimensions in mm	Flange nut FM	Duplex nut DM	Duplex nut DM with SIFA	Self-aligning nut PM	Greasless nut FFDM
	Y/A	Y/A	Y/A	Y/A	Y/A
Bellows FB	256/161	260/179	323/242	319/244	275/195
without bellows FB	-	403/252	462/311	462/317	420/270
2x Z-50-FB-390	-	377/239	436/298	436/304	394/257
2x Z-50-FB-1000	-	493/297	552/356	552/362	510/315
2x Z-50-FB-1200	-	483/292	542/351	542/357	500/310
2x Z-50-FB-1500	-	593/347	652/406	652/412	610/365

Detailed instructions for determining the length can be found in Section 8

# 50 kN

## Technical data series GSZ-50-S / GSZ-50-R

max. compressive/tensile force, static	- 50 kN (5 t)
max. compressive/tensile force, dynamic	- see duty cycle curves
Nominal speed	- 1500 rpm
max. drive shaft speed	- 1800 rpm (depending on the load and duty cycle)
Screw size standard	- Tr 40x7 <sup>2)</sup>
Gear ratio	- 7:1 (N) / 28:1 (L)
Housing material	- GGG-50, corrosion-resistant
Worm shaft	- steel, case-hardened, ground
Weight of screw jack body	- 15 kg
Weight of screw/m	- 8 kg
Gearbox lubrication	- synthetic fluid grease
Screw lubrication	- grease lubrication
Gearbox operating temperature	- max. 60°C, higher on request
Moment of inertia	- N: 6.40 kg cm <sup>2</sup> / L: 2.53 kg cm <sup>2</sup>
Input torque (at 1500 rpm)	- max. 31.5 Nm (N) / max. 10.4 Nm (L)
Drive-through torque	- max. 260 Nm

Drive torque M <sub>G</sub> (Nm)	- F (kN) x 0.68 <sup>3)5)</sup> + M <sub>L</sub> (N-normal) - F (kN) x 0.23 <sup>3)5)</sup> + M <sub>L</sub> (L-low speed)
Breakaway torque	- Drive torque M <sub>G</sub> x 1.5
Idling torque <sup>4)</sup> M <sub>L</sub> (Nm)	- 0.76 (N-normal) / 0.54 (L-low speed)

Between gearbox and nut or nut and end of thread, provide for a safety distance of (minimum) 10 mm!  
See Section 7 for the checklist.

### Important information

- 1) - extension if a bellows or spiral spring is fitted: see the table or Section 8
- 2) - Tr 40x7 is standard, also available: double-pitch, stainless steel, left-handed, increased screw Tr 55x9 (only for the R version)
- 3) - factor includes efficiency, ratio and 30% safety
- 4) - at 20°C, can be higher when new
- 5) - for a 7 mm screw pitch



UNIQUE:  
Screw lubrication  
during operation

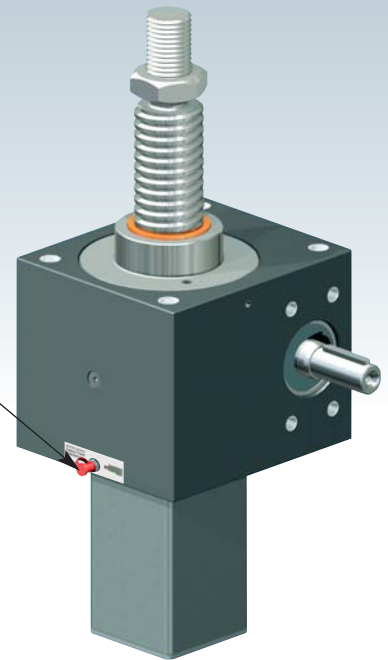

GSZ-100-S translating screw 100 kN

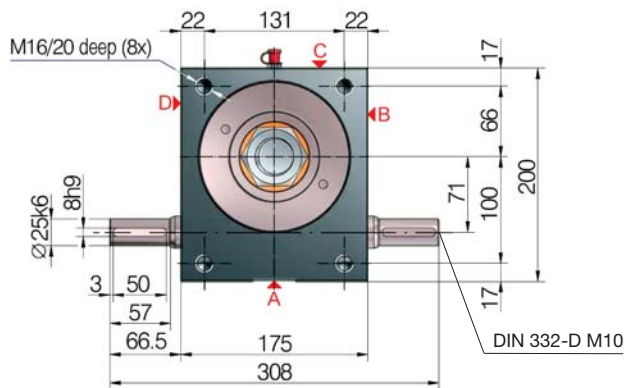
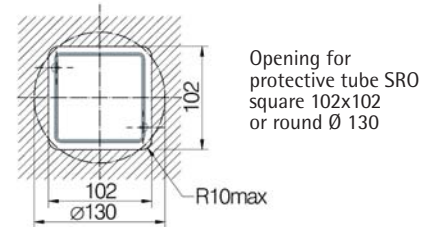
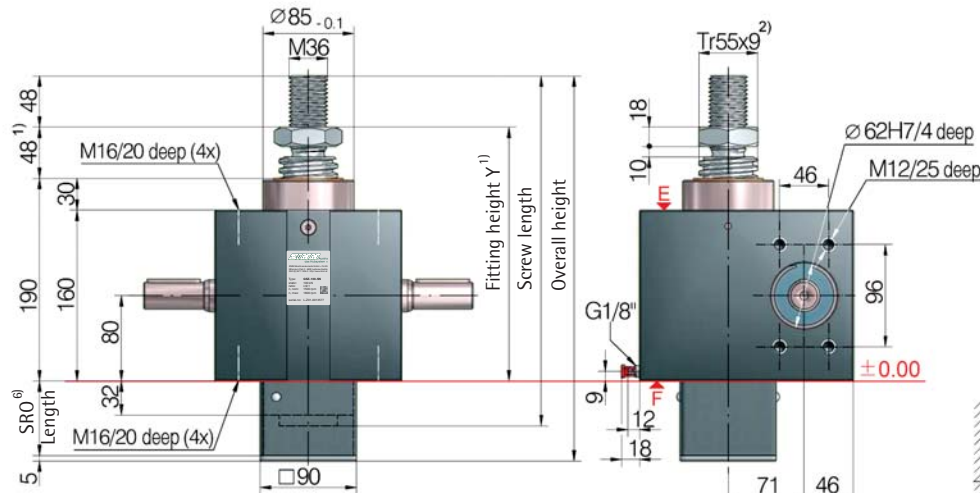

<sup>1)</sup>Fitting height "Y" for 0-stroke, with Tr 55x9 screw

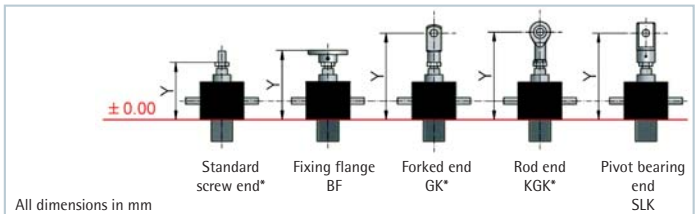

All dimensions in mm

Bellogs FB	Y	Y	Y	Y	Y
without bellogs FB	238	288	382	380	346
Z-100-FB-285	311	313	455	453	371
Z-100-FB-600	308	310	452	450	368
Z-100-FB-1000	366	368	510	508	426
Z-100-FB-1500	416	418	560	558	476

\*with bellows fixing ring Z-100-FBR

<sup>6)</sup>Protective tube length SRO with Tr 55x9 screw

Without escape/ rotation protection	Escape/ rotation protection	Rotation protection, with limit switch set ES	Rotation protection with ES and KAR*
82+stroke	112+stroke	144+stroke	189+stroke

\*Hinged bearing plate KAR, fitted on face F (below)

Standard ratios

Type	Version	Speed	Standard screw <sup>2)</sup>	i	Stroke per drive shaft rotation <sup>5)</sup>
GSZ-100-SN	Translating	Normal	Tr 55x9	9:1	1.00 mm
GSZ-100-SL	screw	Low speed		36:1	0.25 mm
GSZ-100-RN	Rotating	Normal	Tr 55x9	9:1	1.00 mm
GSZ-100-RL	screw	Low speed		36:1	0.25 mm

Screw jack mounting

max. load: 100 kN compressive and tensile load  
Screw: M16, strength class 8.8  
Screw-in depth: 16 to 20 mm  
Tightening torque: 82 Nm  
Screw locking: with Loctite 243

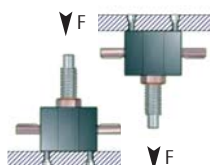

Duty cycle thermal limit, for S+R

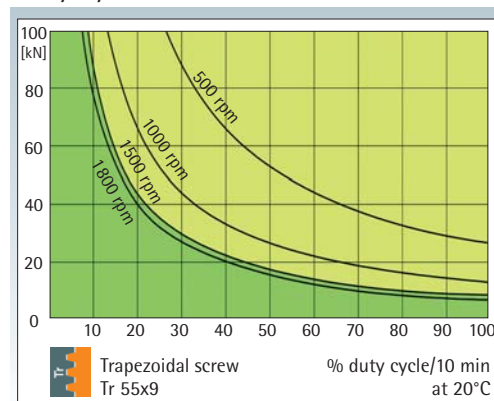

These curves are for guidance under standard industrial conditions (ambient temperature etc.) and correct maintenance (lubrication etc.). The max. input drive torques for optimum service life are at the right page - technical data (1500 rpm)

KGK: % duty cycle 2 times to 4 times higher

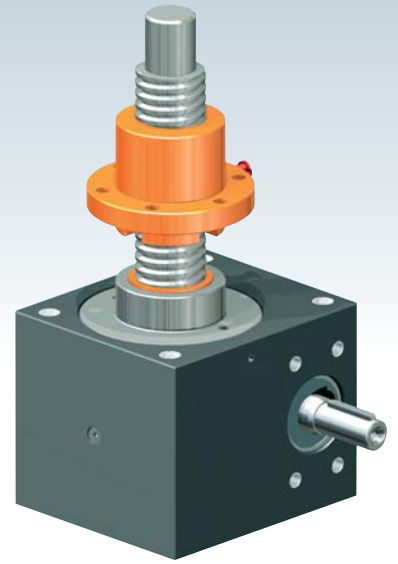

GSZ-100-R rotating screw 100 kN

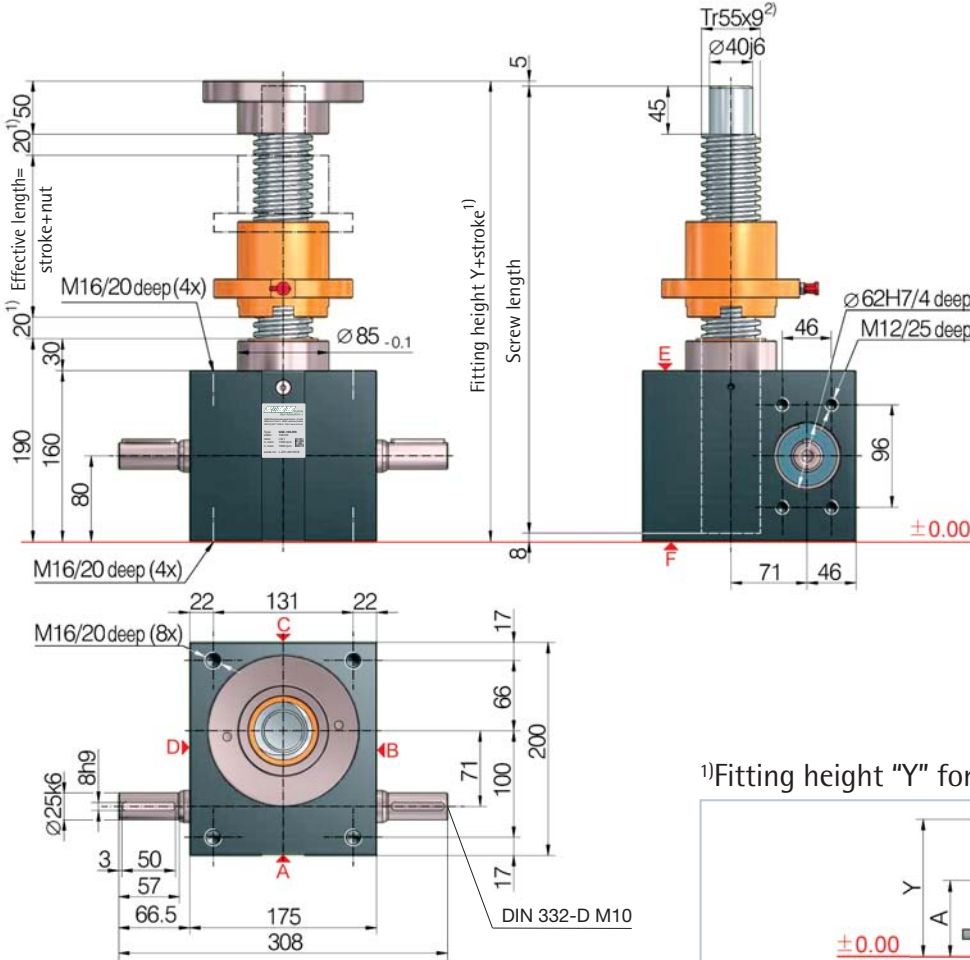

1) Fitting height "Y" for 0-stroke, with Tr 55x9 screw

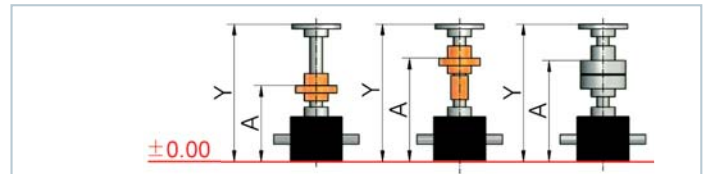

All dimensions in mm	Duplex nut DM	Duplex nut DM with SIFA	Self-aligning nut PM
<b>Bellocs FB</b>	<b>Y/A</b>	<b>Y/A</b>	<b>Y/A</b>
without bellocs FB	370/246	453/329	470/355
2x Z-100-FB-285	478/299	556/377	578/408
2x Z-100-FB-600	472/296	550/374	572/405
2x Z-100-FB-1000	588/354	666/432	688/463
2x Z-100-FB-1500	688/404	766/482	788/513

Detailed instructions for determining the length can be found in Section 8

**100** kN

Technical data series GSZ-100-S / GSZ-100-R

max. compressive/tensile force, static	- 100 kN (10 t)
max. compressive/tensile force, dynamic	- see duty cycle curves
Nominal speed	- 1500 rpm
max. drive shaft speed	- 1800 rpm (depending on the load and duty cycle)
Screw size standard	- Tr 55x9 <sup>3)</sup>
Gear ratio	- 9:1 (N) / 36:1 (L)
Housing material	- GGG-50, corrosion-resistant
Worm shaft	- steel, case-hardened, ground
Weight of screw jack body	- 30 kg
Weight of screw/m	- 15.7 kg
Gearbox lubrication	- synthetic fluid grease
Screw lubrication	- grease lubrication
Gearbox operating temperature	- max. 60°C, higher on request
Moment of inertia	- N: 12.53 kg cm <sup>2</sup> / L: 4.75 kg cm <sup>2</sup>
Input torque (at 1500 rpm)	- max. 53.4 Nm (N) / max. 13.5 Nm (L)
Drive-through torque	- max. 540 Nm

Drive torque $M_G$ (Nm)	- $F$ (kN) $\times$ 0.72 <sup>3)5)</sup> + $M_L$ (N-normal)
Breakaway torque	- $F$ (kN) $\times$ 0.23 <sup>3)5)</sup> + $M_L$ (L-low speed)
Idling torque <sup>4)</sup> $M_L$ (Nm)	- Drive torque $M_G \times 1.5$
	- 1.68 (N-normal) / 1.02 (L-low speed)

Between gearbox and nut or nut and end of thread, provide for a safety distance of (minimum) 20 mm!  
See Section 7 for the checklist.

Important information

- 1) - extension if a bellows or spiral spring is fitted: see the table or Section 8
- 2) - Tr 55x9 is standard, also available: double-pitch, stainless steel, left-handed, increased screw Tr 60x9 (only for the R version)
- 3) - factor includes efficiency, ratio and 30% safety
- 4) - at 20°C, can be higher when new
- 5) - for a 9 mm screw pitch

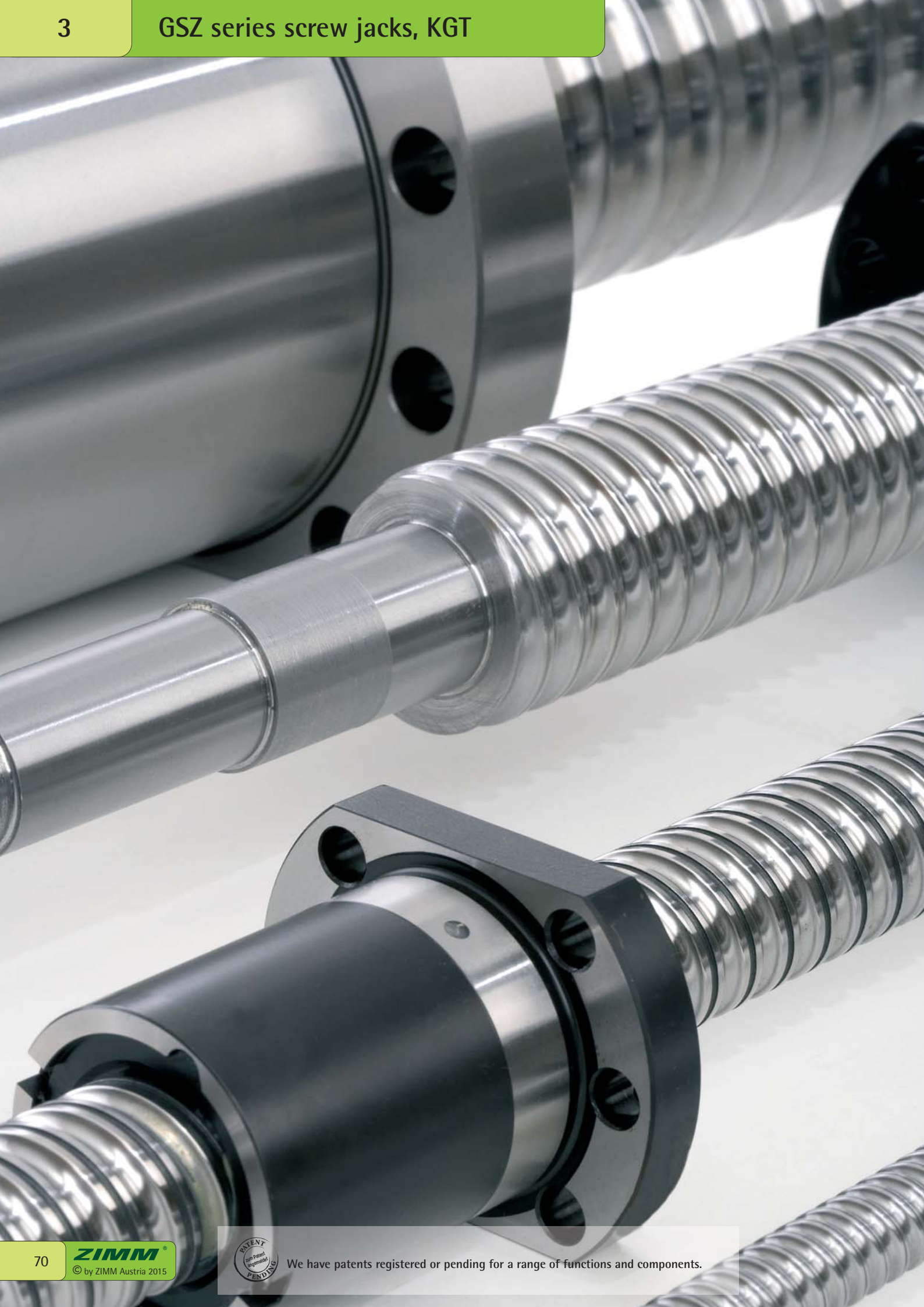



## Ball screw KGT



Most screw jacks use trapezoidal screws Tr, because they are simple, robust and inexpensive. The proportion of screw jacks that use ball screws is however constantly increasing. The reasons for this are primarily their pitch accuracy, their high efficiency (less power consumption and less heat generation) and the higher pitches available, which permit higher stroke speeds.

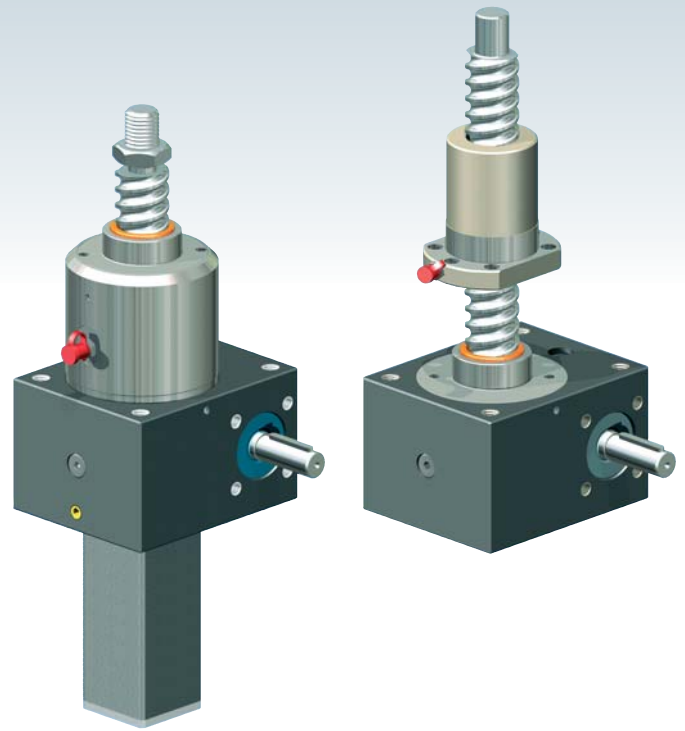

## Technical data KGT

### Pitch accuracy

0.05 mm / 300 mm

Material: 1.1213 (Cf 53), induction hardened and polished.

### No self-locking!

Because of the lack of friction, a holding brake is necessary: a motor brake or a spring pressure brake is required.

### Temperatures, duty cycle

Operating temperature range -20°C to +80°C (when <10° or >40°C please contact us).

The duty cycle can be up to 4 times higher than for trapezoidal screws (see diagrams), and at long strokes up to 2 times higher than for trapezoidal screws.

### Service life

Heavy loads reduce the service life of the KGT. Tell us the load and stroke speed and we will calculate the service life.

### Contamination

All nuts are fitted with scrapers. For heavy contamination and fine dust/chips, we recommend fitting bellows or a spiral spring cover.

### Escape/rotation protection

Under no circumstances may the nut be screwed off the screw. We therefore always provide escape/rotation protection on the S version.

### Start ramp / braking ramp

We recommend using a frequency converter or a servomotor, especially for high lead screw jacks. This allows regulation of the start ramp / braking ramp. This ensures protection for the entire system.

Safety clearance L3 can also be reduced at your own discretion, in particular for high pitches.

### Grease nipples

The standard position of the grease nipple on the S version is on the gearbox face "C". Optionally, face A is available. Faces B and D are available on request.



We have patents registered or pending for a range of functions and components.



UNIQUE:  
Ball screw lubrication  
for the S version

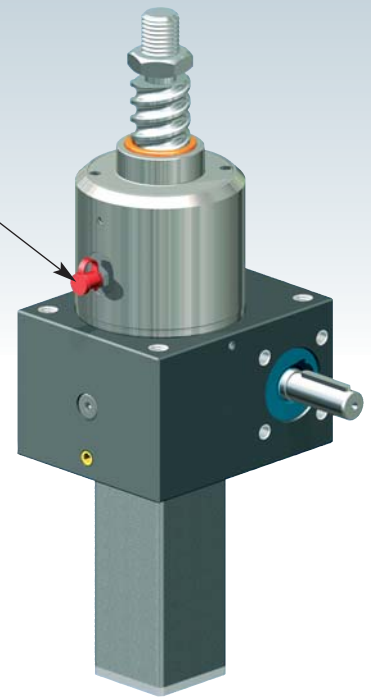

## GSZ-5 to GSZ-100, KGT-S translating screw

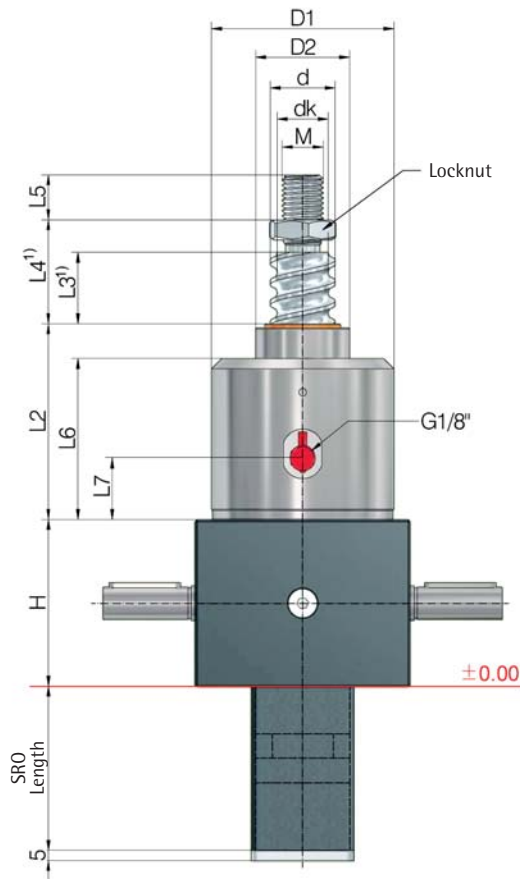

- further technical information: Page 71
- see the respective screw jack page for all other dimensions
- see Section 4 for accessories
- dimensions on the illustrative diagrams are in mm. We reserve the right to make changes.

### Ordering example:

GSZ-100-SN-KGT 50x20, C = 112.4 kN

dynamic load rating C

Screw jacks	Ball screw KGT	Stroke per drive revolution [mm]		KGT load rating [kN]		Dimensions [mm]											Axial play max <sup>5)</sup> [mm]	
		SN	SL	dyn. C <sup>2)</sup>	stat. C <sub>0</sub> =C <sub>0a</sub>	H	d	dk	D <sub>1</sub>	D <sub>2</sub>	L <sub>2</sub>	L <sub>3</sub> <sup>1)</sup>	L <sub>4</sub> <sup>1)</sup>	L <sub>5</sub>	L <sub>6</sub>	L <sub>7</sub>		M
GSZ-5	16x5	1.25	0.31	9.3	13.1	62	15.5	12.9	59	29	66	15	25	19	54	23	M12	0.08
	16x10	2.50	0.63	15.4	26.5	62	15.4	13.0	59	29	66	25	35	19	54	23	M12	0.08
GSZ-10	25x5	1.25	0.31	12.3	22.5	74	24.5	21.9	69	39	85	15	27	20	69	21	M14	0.08
	25x10	2.50	0.63	13.2	25.3	74	24.5	21.9	69	39	85	25	37	20	69	21	M14	0.08
	25x25	6.25	1.56	16.7	32.2	74	24.5	22.0	69	39	85	60	72	20	69	21	M14	0.08
	25x50	12.50	3.13	15.4	31.7	74	24.1	21.5	69	39	85	125	137	20	69	21	M14	0.15
GSZ-25	32x5	0.83	0.21	21.5	49.3	82	31.5	28.9	89	46	99	15	31	22	82	33	M20	0.08
	32x10	1.67	0.42	33.4	54.5	82	32.7	27.3	89	46	99	20	36	22	82	33	M20	0.08
	32x20	3.33	0.83	29.7	59.8	82	31.7	27.9	89	46	99	35	51	22	82	33	M20	0.08
	32x40	6.67	1.67	14.9	32.4	82	30.9	28.3	89	46	99	70	86	22	82	33	M20	0.08
GSZ-50	40x5	0.71	0.18	23.8	63.1	116	39.5	36.9	125	60	93	15	39	29	74	17	M30	0.08
	40x10	1.43	0.36	38	69.1	116	39.5	34.1	125	60	93	15	39	29	74	17	M30	0.08
	40x20	2.86	0.72	33.3	76.1	116	39.7	35.9	125	60	93	30	54	29	74	17	M30	0.08
	40x40	5.71	1.43	35	101.9	116	38.9	36.3	125	60	93	60	84	29	74	17	M30	0.08
GSZ-100	50x10	1.11	0.28	68.7	155.8	160	49.5	44.1	148	85	112	20	48	48	82	19	M36	0.08
	50x20	2.22	0.56	60	136.3	160	49.5	44.1	148	85	112	40	68	48	82	19	M36	0.08
	50x10	1.11	0.28	112.1	338.5	160	50	43.6	148	85	148	20	48	48	118	19	M36	0.03
	50x20	2.22	0.56	112.4	214.7	160	50	41.1	148	85	148	40	68	48	118	19	M36	0.03
	50x40	4.44	1.11	84.7	143.1	160	50	41.1	148	85	148	80	108	48	118	19	M36	0.03

<sup>1)</sup> Depending on the control system and drive, the dimensions L<sub>3</sub> and L<sub>4</sub> can be reduced at your own discretion.  
An extension may be required if a bellows or spiral spring is fitted

<sup>2)</sup> Dynamic load rating to DIN 69051 part 4 draft 1989.

<sup>5)</sup> Reduced play 0.02 mm available on request.

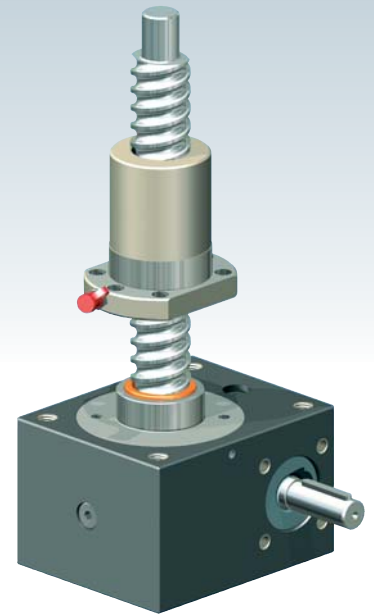

GSZ-2 to GSZ-100, KGT-R rotating screw

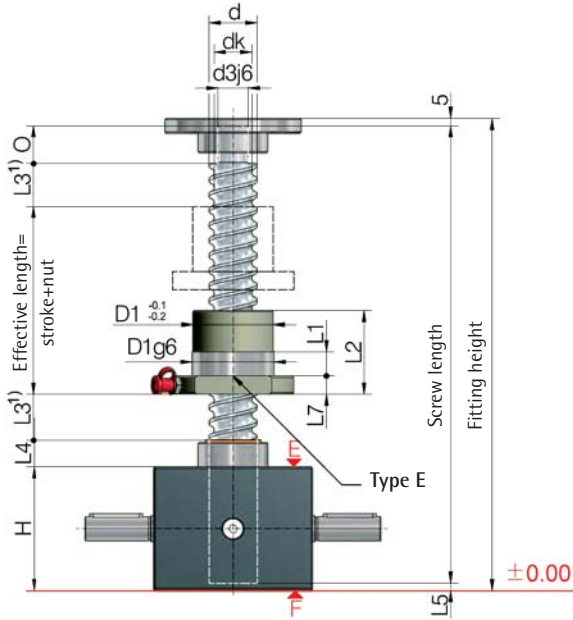

Position of the flange nut:  
G = flange gearbox side  
(as shown)  
S = flange screw side

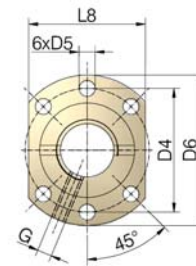
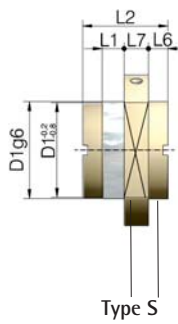

Hole pattern 1 to DIN 69051

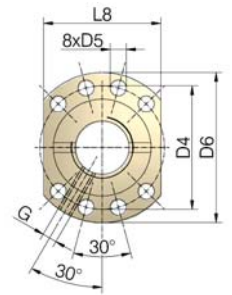

Hole pattern 2 to DIN 69051

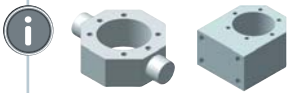

Adapter for KGT  
Dimension sheet on request

An increased screw (such as Z-10-RN with screw 32x10) can also be used for the rotating version.



Ordering example:

GSZ-100-RN-KGT 50x20, C = 112.4 kN - G

dynamic load rating C

Nut flange

G: flange gearbox side

S: flange screw side

Screw jacks	Ball screw KGT	Stroke per drive revolution [mm]		KGT load rating [kN]		Nut Type	Nut Hole pattern	Dimensions [mm]																	Lubrication hole	Axial play max <sup>5)</sup> [mm]
		RN	RL	dyn. C <sup>2)</sup>	stat. C <sub>0</sub> =C <sub>0a</sub>			d	dk	ds	O	H	D <sub>1</sub>	D <sub>4</sub>	D <sub>5</sub>	D <sub>6</sub>	L <sub>1</sub>	L <sub>2</sub>	L <sub>3</sub> <sup>1)</sup>	L <sub>4</sub>	L <sub>5</sub>	L <sub>6</sub>	L <sub>7</sub>	L <sub>8</sub>		
GSZ-2	16x5	1.25	0.31	9.3	13.1	E 1	1	15.5	12.9	10	12	50	28	38	5.5	48	10	42	15	11	3	-	10	40	M6	0.08
	16x10	2.50	0.63	15.4	26.5	E 1	1	15.4	13.0	10	12	50	28	38	5.5	48	10	55	25	11	3	-	10	40	M6	0.08
GSZ-5	16x5	1.25	0.31	9.3	13.1	E 1	1	15.5	12.9	12	15	62	28	38	5.5	48	10	42	15	12	8	-	10	40	M6	0.08
	16x10	2.50	0.63	15.4	26.5	E 1	1	15.4	13.0	12	15	62	28	38	5.5	48	10	55	25	12	8	-	10	40	M6	0.08
GSZ-10	25x5	1.25	0.31	12.3	22.5	E 1	1	24.5	21.9	15	20	74	40	51	6.6	62	10	42	15	16	8	-	10	48	M6	0.08
	25x10	2.50	0.63	13.2	25.3	E 1	1	24.5	21.9	15	20	74	40	51	6.6	62	16	55	25	16	8	-	10	48	M6	0.08
	25x25 <sup>3)</sup>	6.25	1.56	16.7	32.2	S 1	1	24.5	22.0	15	20	74	40	51	6.6	62	9	35	60	16	8	8	10	- <sup>3)</sup>	M6	0.08
	25x50	12.50	3.14	15.4	31.7	S 1	1	24.1	21.5	15	20	74	40	51	6.6	62	10	58	125	16	8	10	10	48	M6	0.15
GSZ-25	32x5	0.83	0.21	21.5	49.3	E 1	1	31.5	28.9	20	25	82	50	65	9.0	80	10	55	15	17	5	-	12	62	M6	0.08
	32x10	1.67	0.42	33.4	54.5	E 1	1	32.7	27.3	20	25	82	53 <sup>4)</sup>	65	9.0	80	16	69	20	17	5	-	12	62	M8x1	0.08
	32x20	3.33	0.83	29.7	59.8	E 1	1	31.7	27.9	20	25	82	53 <sup>4)</sup>	65	9.0	80	16	80	35	17	5	-	12	62	M6	0.08
	32x40 <sup>3)</sup>	6.67	1.67	14.9	32.4	S N <sup>4)</sup>	1	30.9	28.3	20	25	82	53 <sup>4)</sup>	68 <sup>4)</sup>	7.0 <sup>4)</sup>	80	14	45	70	17	5	7.5	16	- <sup>3)</sup>	M6	0.08
GSZ-50	40x5	0.71	0.18	23.8	63.1	E 2	2	39.5	36.9	25	30	116	63	78	9	93	10	57	15	19	7	-	14	70	M6	0.08
	40x10	1.43	0.36	38	69.1	E 2	2	39.5	34.1	25	30	116	63	78	9	93	16	71	15	19	7	-	14	70	M8x1	0.08
	40x20	2.86	0.72	33.3	76.1	E 2	2	39.7	35.9	25	30	116	63	78	9	93	16	80	30	19	7	-	14	70	M8x1	0.08
	40x40	5.71	1.43	35	101.9	S 2	2	38.9	36.3	25	30	116	63	78	9	93	16	85	60	19	7	7.5	14	- <sup>3)</sup>	M8x1	0.08
GSZ-100	50x10	1.11	0.28	68.7	155.8	E 2	2	49.5	44.1	40	45	160	75	93	11	110	16	95	20	30	8	-	16	85	M8x1	0.08
	50x20	2.22	0.56	60	136.3	E 2	2	49.5	44.1	40	45	160	85 <sup>4)</sup>	103 <sup>4)</sup>	11	125 <sup>4)</sup>	22	95	40	30	8	-	18	95	M8x1	0.08
	50x10	1.11	0.28	112.1	338.5	E 2	2	50	43.6	40	45	160	75	93	11	110	16	107	20	30	8	-	16	85	M8x1	0.03
	50x20	2.22	0.56	112.4	214.7	E 2	2	50	41.1	40	45	160	85 <sup>4)</sup>	103 <sup>4)</sup>	11	120 <sup>4)</sup>	16	125	40	30	8	-	16	95	M8x1	0.03
	50x40	4.44	1.11	84.7	143.1	E 2	2	50	41.1	40	45	160	85 <sup>4)</sup>	103 <sup>4)</sup>	11	120 <sup>4)</sup>	16	125	80	30	8	-	16	95	M8x1	0.03
50x50 <sup>4)</sup>	5.56	1.39	84.7	143.1	E 2	2	50	41.1	40	45	160	85 <sup>4)</sup>	103 <sup>4)</sup>	11	120 <sup>4)</sup>	16	145	100	30	8	-	16	95	M8x1	0.03	

<sup>1)</sup> An extension may be required if a bellows or spiral spring is fitted.

<sup>2)</sup> Dynamic load rating to DIN 69051 part 4 draft 1989.

<sup>3)</sup> Round flange.

<sup>4)</sup> Non-preferred design.

<sup>5)</sup> Reduced play 0.02 mm available on request.

<sup>6)</sup> Not to DIN 69051.

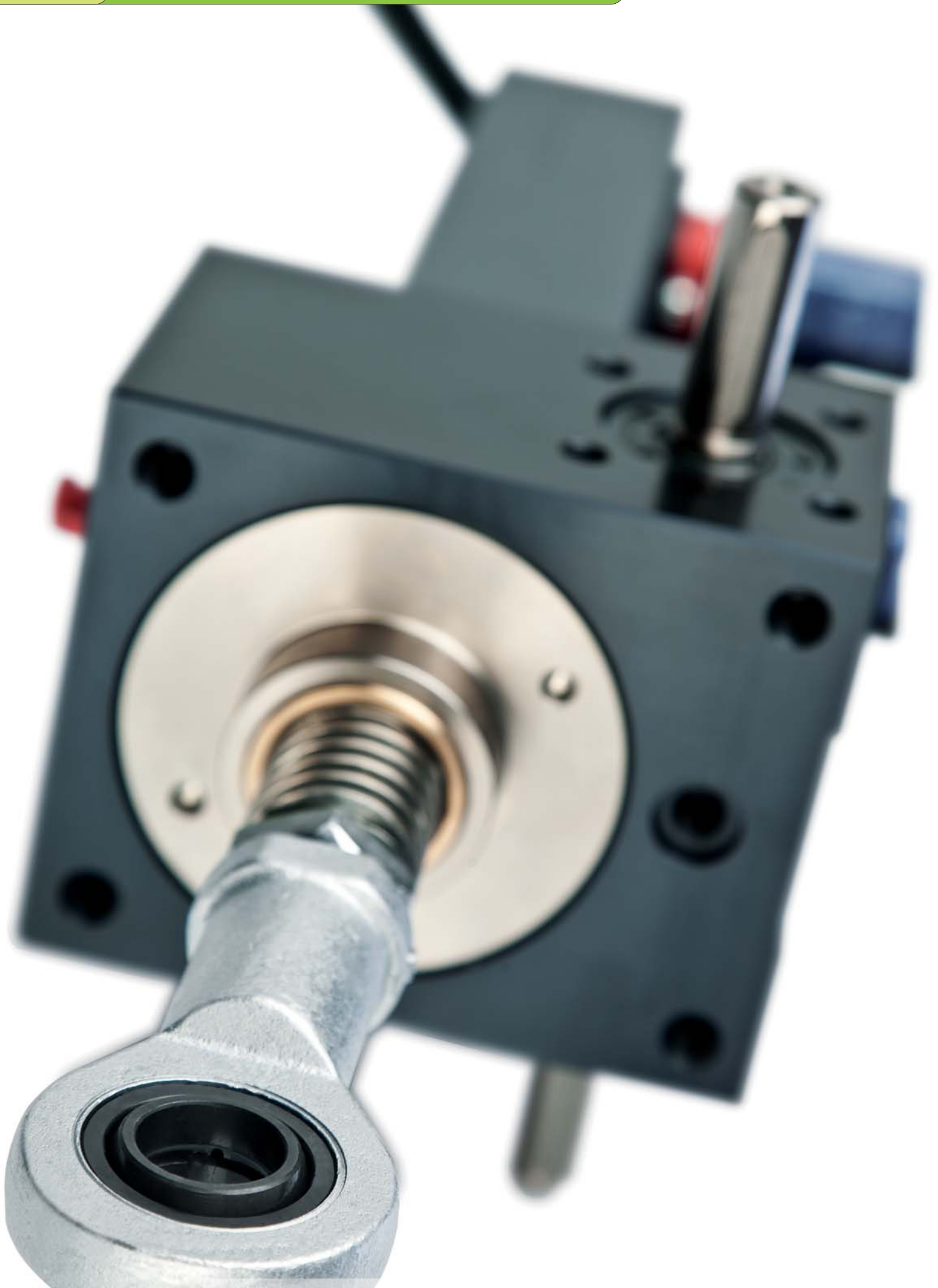

## Safety nut SIFA



### Function

A safety nut is designed for use where stripping and break up of the thread could cause a hazard to persons.

A safety nut can also provide protection for other equipment against the consequences of machine failures and downtimes.

### Wear

Once the wear exceeds max. 25% of the screw pitch, the load nut (R) or the gearbox (S) must be replaced.

### Monitoring

Wear and thread play should be checked and documented at regular intervals (depending on the duty cycle).

This allows the fitting of replacement parts to be planned ahead, reducing unscheduled system downtime.

### Electrical monitoring

Electrical monitoring gives a signal when wear reaches approx. 25%. This signal can be displayed immediately at a central control point. Replacement of the worn parts can then be scheduled.

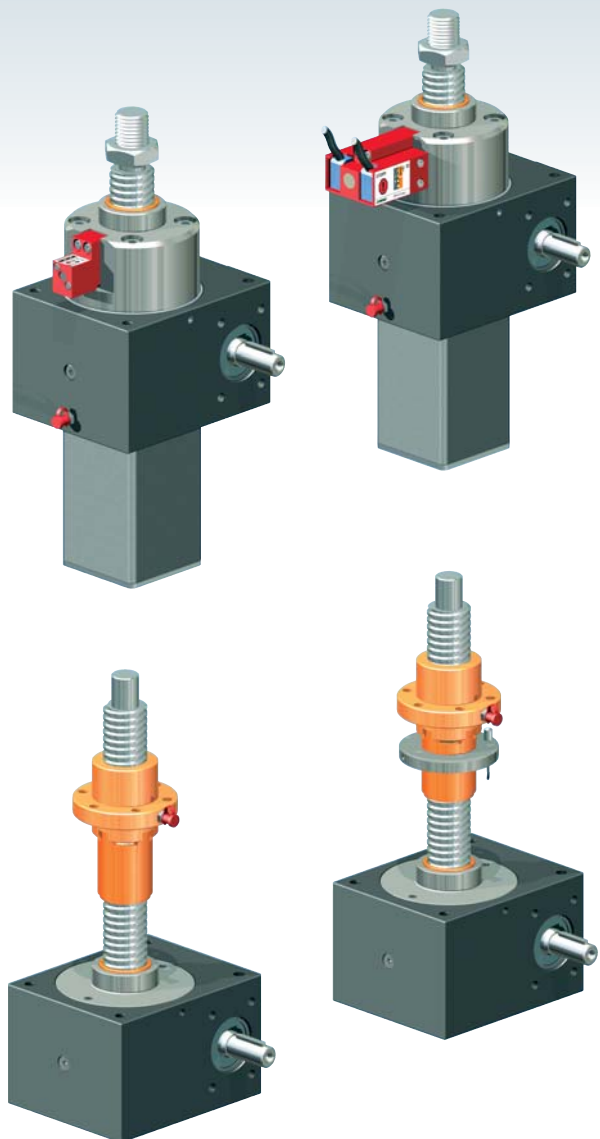

Screw jacks	Pitch P	max. permissible wear/ thread play* (25% of P)
[TrØxP]	[mm]	[mm]
Tr16x4, Tr18x4, Tr20x4	4	1.0
Tr30x6	6	1.5
Tr40x7	7	1.75
Tr 55x9	9	2.25

\* Identical for double pitch screws (same thread flank thickness)

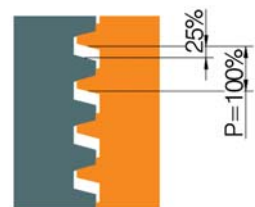

max. 25% wear



We have patents registered or pending for a range of functions and components.



SIFA-S translating screw

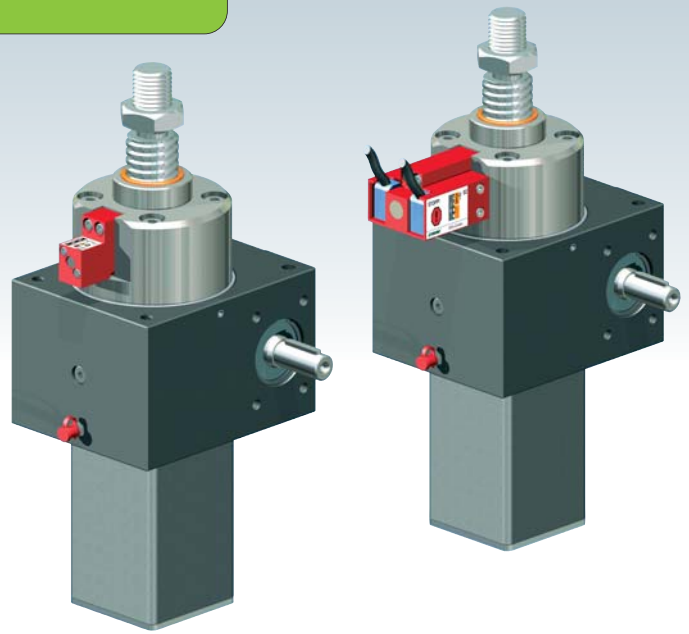

Function S version



The load is borne by the worm wheel via the screw. If the worm wheel screw thread wears through, the SIFA restrains the screw. The load remains supported.

Direction of loading, compressive and tensile  
The new SIFA-S operates equally in both compressive and tensile directions of loading!

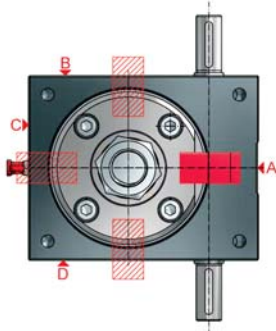
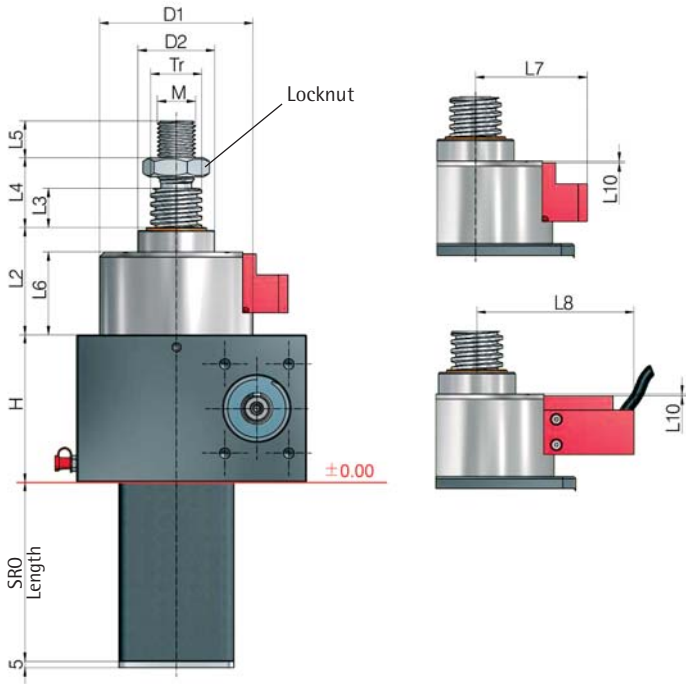

Ordering code:

GSZ-50-SN-SIFA-OP-A

Version  
SN or SL  
Monitoring  
OP: visual  
EL: electrical (wear, thread stripping)  
ELV: only wear  
ELD: only thread stripping  
NO: without any monitoring  
Position  
A (standard), B, C or D  
(can also subsequently be rotated steplessly through 360°)

**i** further technical information: Page 75

Screw jack	Stroke travel/rev.		Tr thread	H	D1	D2	L2	L3 <sup>1)</sup>	L4 <sup>1)</sup>	L5	L6	L7	L8	L9	L10	M
	SN	SL														
GSZ-10	1	0.25	20x4	74	81	39	74	10	22	20	58	72	108	21	1	M14
GSZ-25	1	0.25	30x6	82	92	46	76	10	26	22	59	79	114	25	1	M20
GSZ-50	1	0.25	40x7	116	120	60	84	10	34	29	65	88	123	58	1	M30
GSZ-100	1	0.25	55x9	160	135	85	103	20	48	48	73	95	130	80	9	M36

<sup>1)</sup> See Section 8 for extension if bellows or spiral spring is fitted

## SIFA-S, monitoring

### Visual

#### Monitoring

Wear should be checked and documented at regular intervals. This allows the fitting operation for replacement to be planned in good time so as to avoid system downtime.

#### OK

Wear still <25% of P

#### CAUTION!

max. permissible wear reached –  
Replace the gearbox

#### STOP!

Wear >25% or thread already worn through –  
Stop operation immediately!

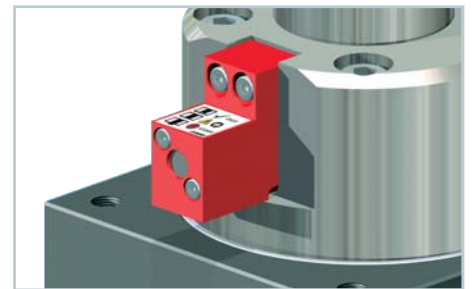
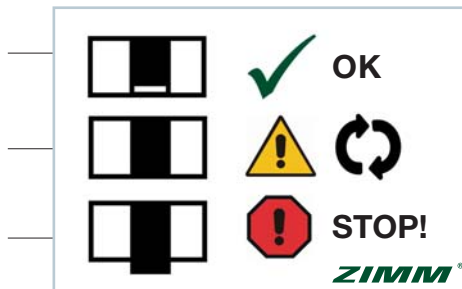

### Electrical

#### WARNING! Switch S1

At 25% wear the limit switch S1 trips. The customer must detect this signal. This enables substitution to be planned well in advance and therefore prevents any unnecessary downtime.



#### STOP! Switch S2

If after the first signal operation of the jack continues, the nut will continue to wear until the thread is worn through. When the thread is worn through, the safety nut takes the load. The limit switch S2 trips. The customer must detect this signal and stop the system.

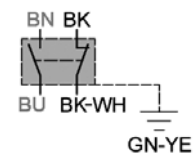

Use only NC relays for safety applications!

### Without any monitoring

If the version used has no monitoring, the dimension A must be measured and documented when new, then regularly checked and documented.

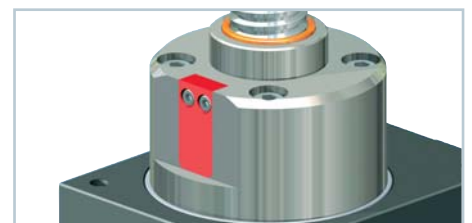
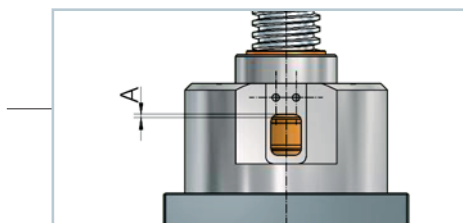



SIFA-R rotating screw

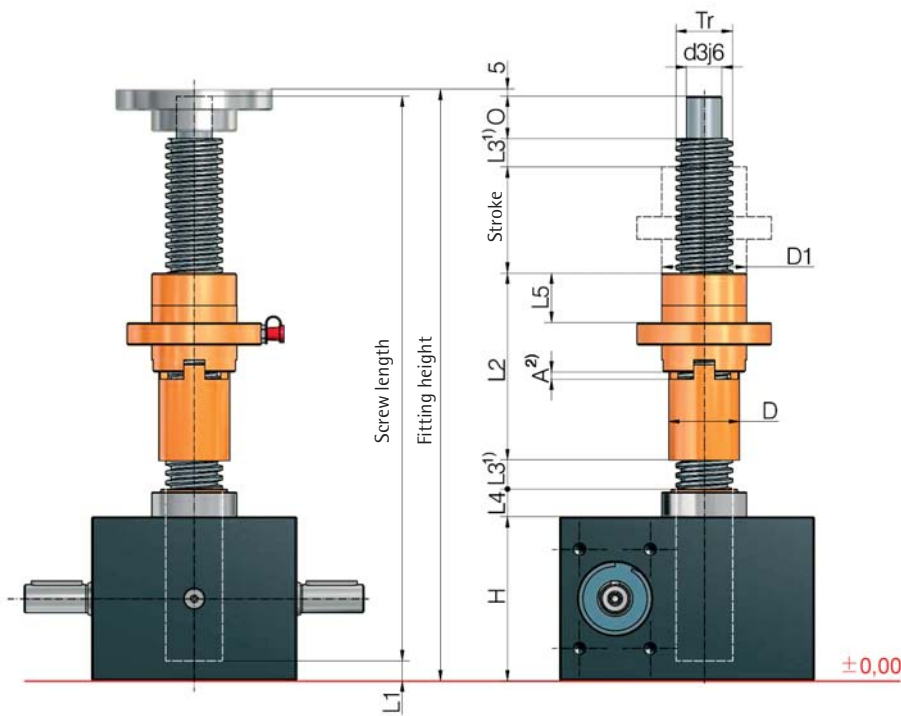
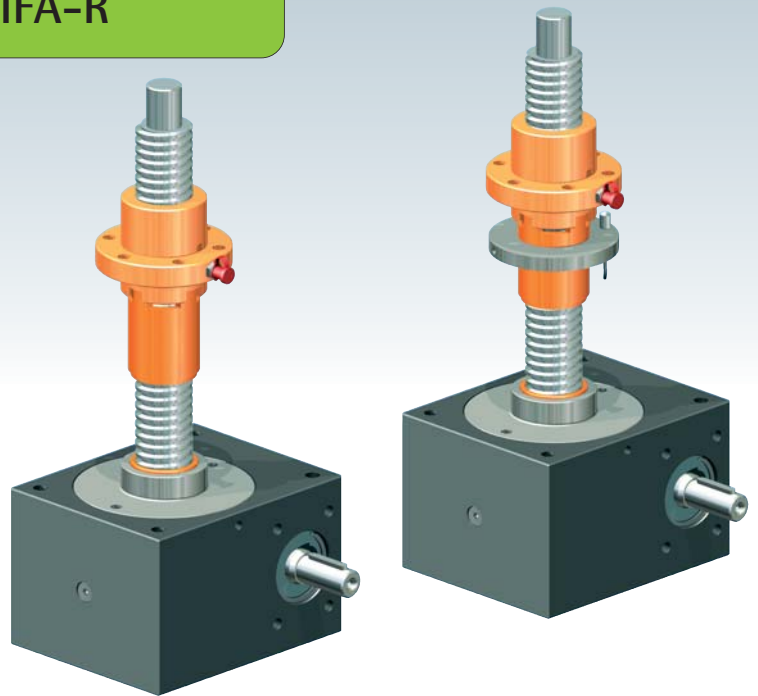

Function R version



The load is borne by the duplex nut. The safety nut runs alongside the duplex nut, bearing no load. If the nut thread is worn through due to wear, the SIFA takes the load on the duplex nut.

**Direction of loading, compressive or tensile**  
A drawing showing the direction of loading is necessary in order to ensure the safety function. The SIFA-R operates in only one direction of loading.

- further technical information: Page 75
- see the respective screw jack page for all other dimensions
- see Section 4 for accessories
- SIFA in combination with self-aligning nut PM available on request

Screw jacks	Tr thread	H	D1	D	d3j6	O	L1	L2	L3 <sup>1)</sup>	L4	L5	A <sup>2)</sup>
GSZ-2	16x4	50	26	22	10	12	3	70	10	11	20	3
GSZ-5	18x4	62	29	24	12	15	8	70	10	12	20	3
GSZ-10	20x4	74	39	28	15	20	8	84	10	16	20	3
GSZ-25	30x6	82	46	38	20	25	5	95	10	17	23	4
GSZ-50	40x7	116	60	50	25	30	13	133	10	19	36	4
GSZ-100	55x9	160	85	65	40	45	10	173	20	30	54	6

Make sure you fit it the right way up:

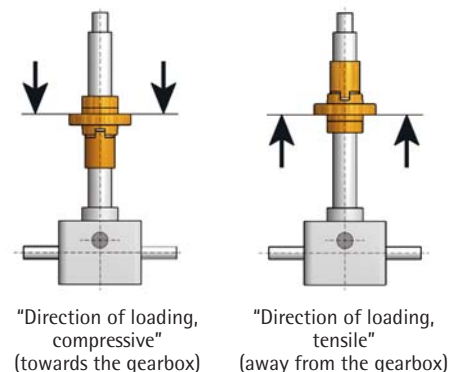

<sup>1)</sup> See Section 8 for extension if bellows or spiral spring is fitted  
<sup>2)</sup> approx. original setting, must be measured and documented by the customer, and referred to when checking



## SIFA-R, monitoring

### Visual

Dimension A is approx. the original setting. Dimension A must be measured and documented by the customer, and referred to when checking. This enables substitution to be planned well in advance and therefore prevents any unnecessary downtime. When the thread is worn through, take the equipment out of service immediately.

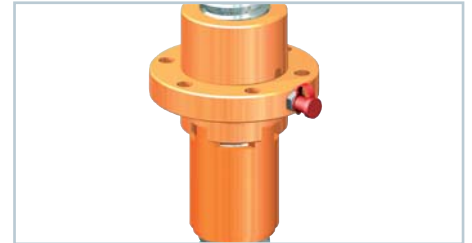
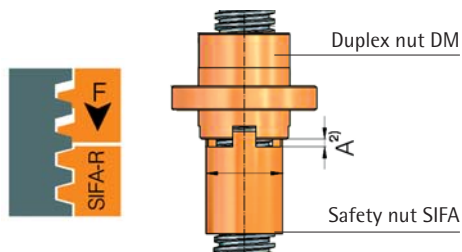

### Electrical

The initiator must be set that it switches off when the load nut reaches 25% of the wear. This enables a replacement to be planned well in advance and therefore prevents any unnecessary downtime. When the thread is worn through, take the system out of service immediately.

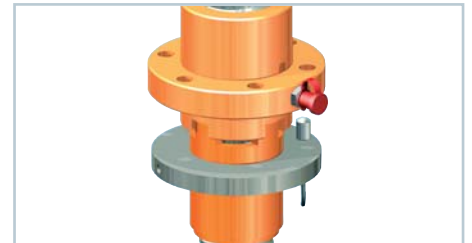
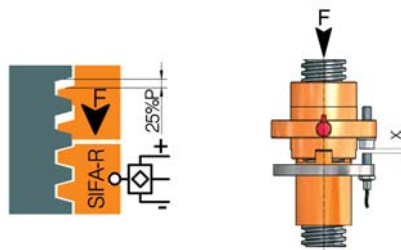

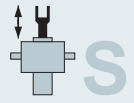

## For the translating version S



Trapezoidal screws  
S-Tr  
Page 82

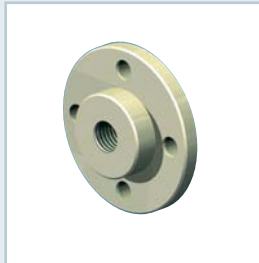

Fixing flange  
BF  
Page 82

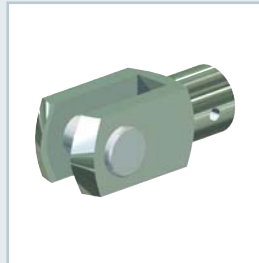

Forked end  
GK  
Page 82



Rod end  
KGK  
Page 82

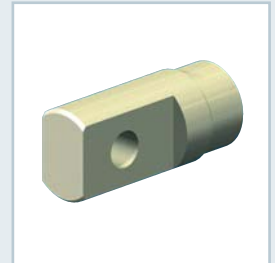

Pivot bearing end  
SLK  
Page 83

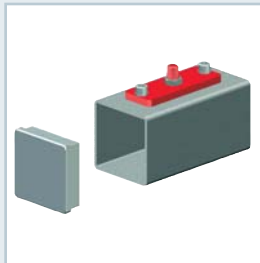

Protective tube  
SRO  
Page 83

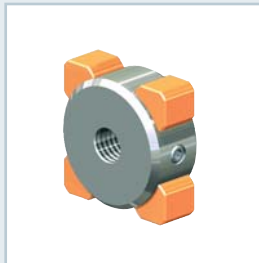

Rotation protection  
VS  
Page 83



Escape protection  
AS  
Page 83

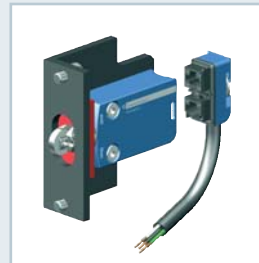

Limit switch set  
ES  
Page 84

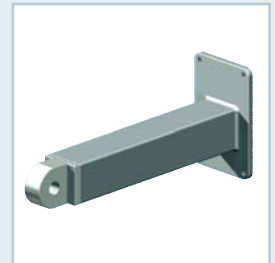

Pivoting support tube  
STRO  
Page 86

## For the rotating version R

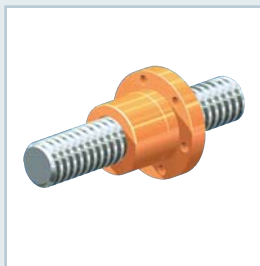
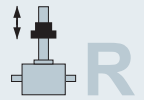

Flange nut  
FM  
Page 88

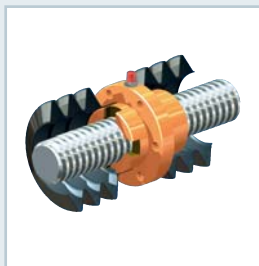

Duplex nut  
DM  
Page 89

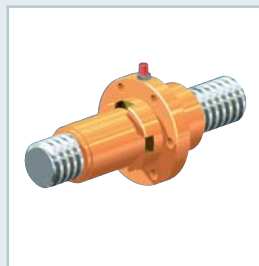

Safety nut  
SIFA  
Page 89



Cardan adapter  
DMA for DM  
Page 89

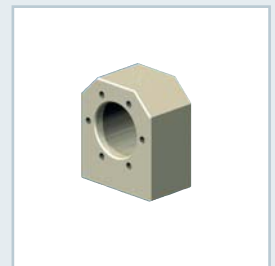

Driving flange  
TRMFL for FM  
Page 89

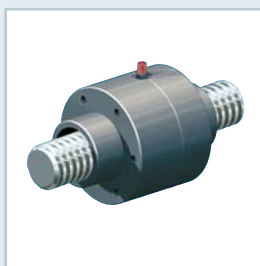

Self-aligning nut  
PM  
Page 90

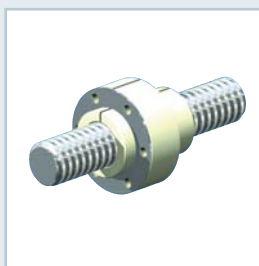

Greaseless nut  
FFDM  
Page 90



Trapezoidal screw  
R-Tr  
Page 91



Opposed bearing plate  
GLP  
Page 91

**NOTE:**  
the accessories are suitable for Z and GSZ screw jacks. See also the overview on pages 6 and 7.

## For S and R versions

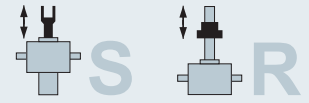

**Bellows**  
FB  
Page 92

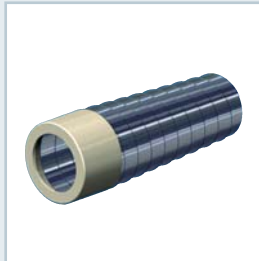

**Spiral spring**  
SF  
Page 94



**Pivot mounts**  
LB  
Page 96

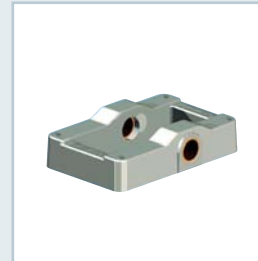

**Pivot bearing plate**  
KAR  
Page 96



**Handwheel**  
HR  
Page 98



**Protective cap**  
SK  
Page 98



for GSZ series

**Fixing strips**  
BFL  
Page 99



for GSZ series

**Pivot bearing plate**  
KAR  
Page 99



**Connecting shaft**  
VWZ  
Page 100

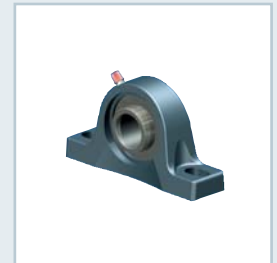

**Pedestal bearing**  
STL  
Page 103

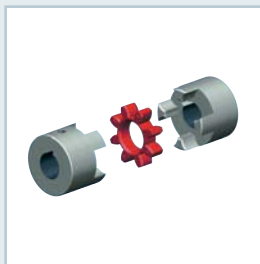

**Standard coupling**  
KUZ  
Page 104

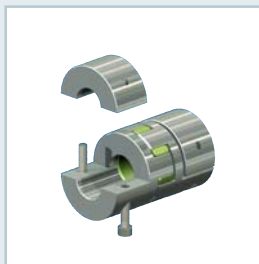

**Clamp coupling**  
KUZ-KK  
Page 105

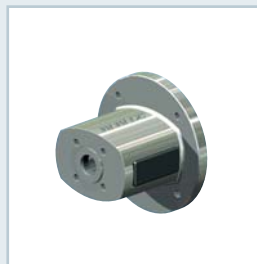

**Motor flange**  
MF  
Page 106

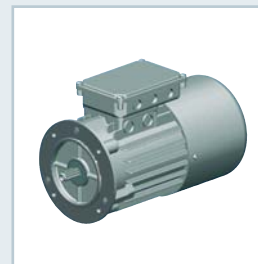

**Three-phase AC motor**  
AC  
Page 110



**DC motor**  
DC  
Page 111



**Rotary pulse encoder**  
DIG  
Page 116



**Spring pressure brake**  
FDB  
Page 118



**Lubricants**  
Page 120



**Lubricator**  
Z-LUB  
Page 120



We have patents registered or pending for a range of functions and components.

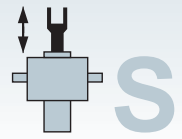

## For the translating version S

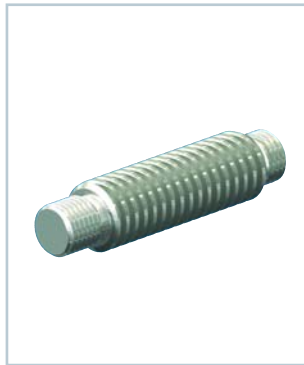

### Trapezoidal screw Z-...-S-Tr

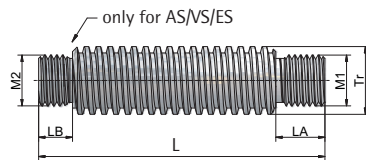

Material: St 60, C35, C45 (stainless steel), double-pitch, left-handed, on request, quality 7e DIN 103, pitch accuracy 0.2 mm/300 mm  
Rolled as standard, from Tr 80 whirled

Part no.	Tr	M1	LA	M2	LB	kg/m
GSZ-2-S-Tr	Tr 16x4	M10	24	M10	15	1.2
Z-5-S-Tr	Tr 18x4	M12	29	M12	15	1.6
Z-10-S-Tr	Tr 20x4	M14	32	M14	20	2.0
Z-25-S-Tr	Tr 30x6	M20	38	M20	20	4.5
Z-35-S-Tr	Tr 40x7	M30	53	M24	30	8.0
Z-50-S-Tr	Tr 40x7	M30	53	M30	30	8.0
Z-50/Tr50-S-Tr	Tr 50x8	M36	76	M36	30	13
Z-100-S-Tr	Tr 55x9	M36	76	M36	30	16
Z-150-S-Tr	Tr 60x9	M42x2	48	M48x2	30	19
Z-250-S-Tr	Tr 80x16	M56x2	58	M64x3	30	32
Z-350-S-Tr	Tr 100x16	M72x3	78	M72x3	35	52
Z-500-S-Tr	Tr 120x16	M100x3	118	M85x3	40	77
Z-750-S-Tr	Tr 140x20	M110x3	130	M100x3	40	105
Z-1000-S-Tr	Tr 160x20	M110x3	130	M100x3	40	139

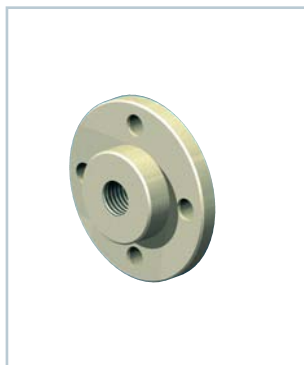

### Fixing flange BF

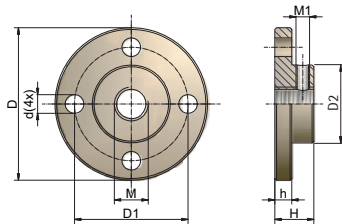

Part no.	D	D1	D2	M	d	h	H	M1	kg
GSZ-2-BF	50	40	26	M10	5.5	6	16	5	0.04
Z-5-BF	65	48	29	M12	9	7	20	5	0.21
Z-10-BF	80	60	38	M14	11	8	21	6	0.38
Z-25-BF	90	67	46	M20	11	10	23	8	0.57
Z-35/50-BF	110	85	60	M30	13	15	30	8	1.20
Z-100-BF	150	117	85	M36	17	20	50	10	3.50
Z-150-BF	170	130	90	M42x2	21	25	50	10	4.70
Z-250-BF	210	165	120	M56x2	26	30	60	12	9.50
Z-350-BF	260	205	145	M72x3	32	40	80	16	18.4
Z-500-BF	310	240	170	M100x3	38	40	120	16	30.0
Z-750-BF	340	265	200	M110x3	38	50	132	20	36.0

Material: steel, corrosion-resistant; aluminium, hard anodised (GSZ-2-BF) identical to the previous MSZ type

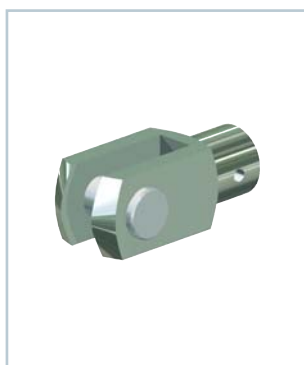

### Forked end GK

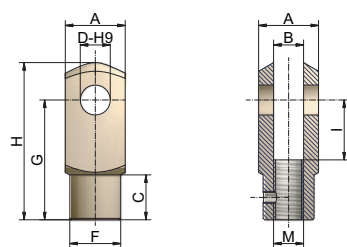

Part no.	A	B	C	D	M	F	G	H	I	kg
GSZ-2-GK	20	10	15	10	M10	18	40	52	20	0.10
Z-5-GK	24	12	18	12	M12	20	48	62	24	0.16
Z-10-GK	27	14	22	14	M14	24	56	72	28	0.24
Z-25-GK	40	20	30	20	M20	34	80	105	40	0.71
Z-35/50-GK	60	30	42	30	M30	52	120	160	60	2.48
Z-100-GK	70	36	54	35	M36	60	144	188	72	3.70
Z-150-GK	85	42	63	42	M42x2	70	168	232	84	5.30

Material: steel, galvanised (stainless steel on request) incl. bolt and cotter pin  
identical to the previous MSZ type



### Rod end KGK

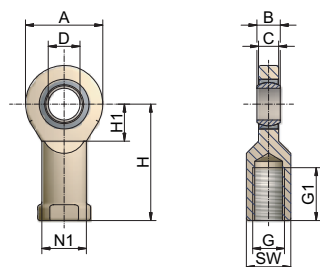

Part no.	A	B	C	D	G	G1	H	H1	SW	N1	kg
GSZ-2-KGK	31	14	12	10	M10	19	43	15	16	15	0.11
Z-5-KGK*	34	10	8	12	M12	23	50	17.5	18	17	0.10
Z-10-KGK*	40	12	10	15	M14	30	61	20	21	20	0.16
Z-25-KGK*	53	16	13	20	M20	40	77	27.5	30	27.5	0.32
Z-35/50-KGK*	73	22	19	30	M30	56	110	37	41	40	1.00
Z-100-KGK	92	28	24	40	M36	65	142	46	60	52	1.90
Z-150-KGK*	112	35	31	50	M42x2	68	160	56	70	62	3.60
Z-250-KGK	160	49	43	70	M56x2	80	200	80	85	80	8.30

CAUTION: Use only with rotation protection  
Material: steel/steel, galvanised; steel/PTFE for GSZ-2-KGK (stainless steel on request)  
\*identical to the previous MSZ type

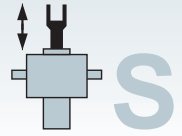

## For the translating version S

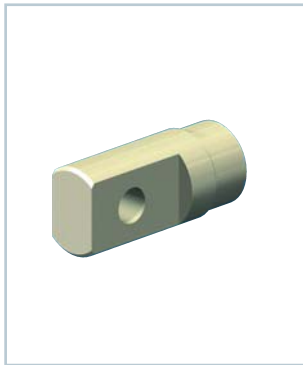

### Pivot bearing end SLK

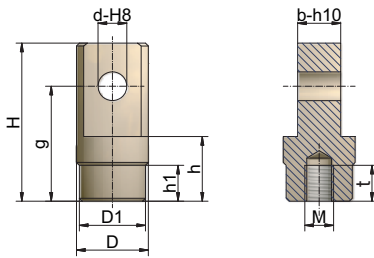

Part no.	H	D	D1	d	M	g	b	h	h1	t	kg
Z-5-SLK	65	30	29	12	M12	48	18	25	20	22	0.25
Z-10-SLK	80	40	39	14	M14	56	24	25	20	25	0.56
Z-25-SLK	110	50	46	20	M20	80	30	45	25	25	1.20
Z-35/50-SLK	130	65	60	30	M30	92	35	50	-	33	2.10
Z-100-SLK	144	90	85	35	M36	108	40	65	-	55	4.40
Z-150-SLK	210	100	90	50	M42x2	155	57	90	50	70	8.00
Z-250-SLK	260	125	120	80	M56x2	180	80	85	40	63	16.00
Z-350-SLK	280	145	145	95	M72x3	195	100	105	-	83	24.00
Z-500-SLK	335	170	170	110	M100x3	245	120	155	80	120	38.00
Z-750-SLK	380	225	200	120	M110x3	270	130	155	80	133	68.50

Material: steel, corrosion-resistant identical to the previous MSZ type

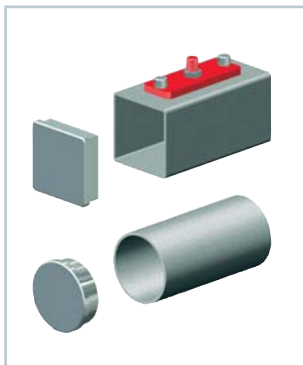

### Protective tube SRO with cover

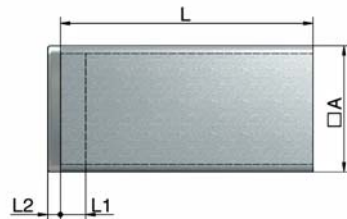

Material: Steel, powder-coated;  
Aluminium, black anodised  
(GSZ-2-SRO)

Cover: Aluminium, corrosion-resistant;  
PE, black (GSZ-2)

Part no.	A	L1	L2	kg/m
GSZ-2-SRO	35x25	14	5	0.6
Z-5-SRO	35	10	5	2.1
Z-10-SRO	50	10	5	3.1
Z-25-SRO	50	10	5	3.1
Z-35-SRO	60	10	5	3.8
Z-50-SRO	90	10	5	8.2
Z-100-SRO	90	10	5	8.2
Z-150-SRO	120	10	5	11.5
Z-250-SRO	Ø125 / 120	10	5	7.6 / 11.5
Z-350-SRO	Ø150 / 160	15	5	19.0 / 19.3
Z-500-SRO	Ø180 / 180	15	5	22.0 / 27.0
Z-750-SRO	Ø210 / 200	15	5	26.0 / 30.0
Z-1000-SRO	Ø260 / 220	15	5	32.0 / 39.0

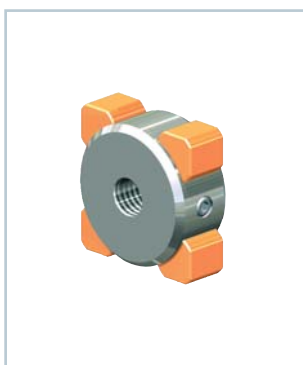

### Rotation protection VS

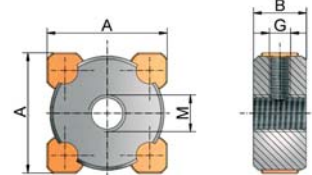

Material: \*Steel, bronze  
Rotation protection is required if the screw is not fixed to the load so that it cannot rotate, or is installed in combination with limit switches or the rod end KGK.

Part no.	A	B	G	M	kg
GSZ-2-VS*	31x21	15	Ø3	M10	0.01
Z-5-VS*	31	15	M6	M12	0.10
Z-10-VS	46	20	M8	M14	0.23
Z-25-VS	46	20	M8	M20	0.23
Z-35-VS	56	30	M8	M24	0.65
Z-50-VS	84	30	M10	M30	1.27
Z-100-VS	84	30	M10	M36	1.20
Z-150-VS	114	30	M12	M48x2	2.15
Z-250-VS	114	30	M12	M64x3	2.15
Z-350-VS	152	35	M16	M72x3	4.6
Z-500-VS	170	40	M16	M85x3	6.6
Z-750-VS	190	40	M16	M100x3	8.0
Z-1000-VS	208	40	M16	M100x3	10.2

\*for Z-5 the rotation protection is of solid bronze; GSZ-2 POM



### Escape protection AS

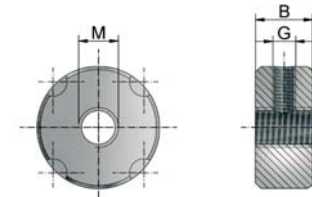

Material: Steel  
Escape protection prevents the screw being wound out of the gearbox. It is particularly recommended for ball screws. Do not rely on it as an operating travel stop.

Part no.	B	G	M	kg
GSZ-2-AS	15	M5	M10	0.01
Z-5-AS	15	M6	M12	0.05
Z-10-AS	20	M8	M14	0.16
Z-25-AS	20	M8	M20	0.14
Z-35-AS	30	M8	M24	0.40
Z-50-AS	30	M10	M30	0.80
Z-100-AS	30	M10	M36	0.74
Z-150-AS	30	M12	M48x2	1.48
Z-250-AS	30	M12	M64x3	1.17
Z-350-AS	35	M16	M72x3	2.87
Z-500-AS	40	M16	M85x3	3.86
Z-750-AS	40	M16	M100x3	6.00
Z-1000-AS	40	M16	M100x3	9.60

## Limit switch set

### Product features

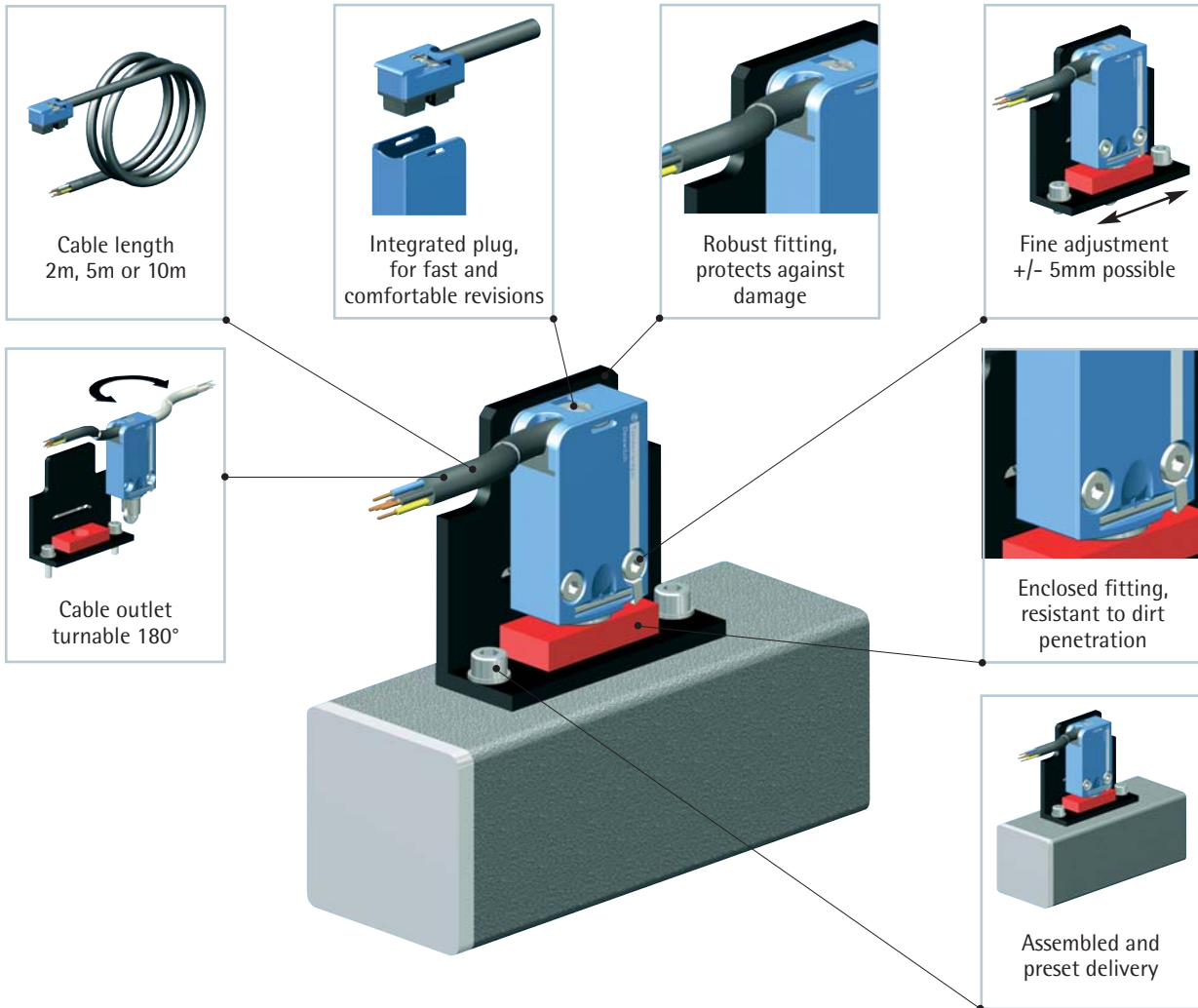

### Technical data

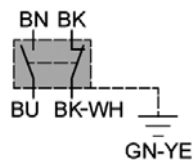
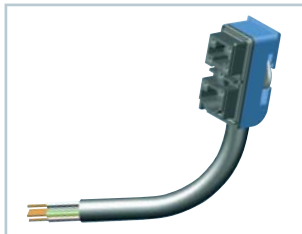

Type:	mechanical limit switch with positively-actuated NC relay
Material:	metal housing and roller plunger
Mode of operation:	1NC + 1NO, snap action contacts
Protection class:	IP67
Temperature range:	-40°C to +70°C
Cable standard – material:	PvR black Ø 7.3mm, 5 x 0.75mm²
Cable standard – temperature:	-25°C to +70°C
Cable special – temperature:	-40°C to +105°C (only request available)
Electrical duty:	max. 240V AC / 1.5A max. 250V DC / 0.1A
Electrical service life:	5 million DC switching operations at 24V DC/3W 1 million AC switching operations at 230V AC/0.5A
Weight:	Limit switch set: 0.15 kg; Cable (5m): 0.45 kg

⚡ NC	— BK	black
	— BK-WH	black-white
⚡ NO	— BU	blue
	— BN	brown
⚡ Protective earth conductor	— GN-YE	green-yellow



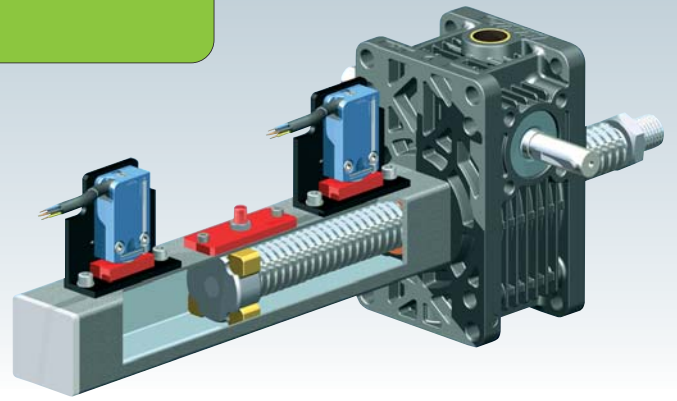

## Limit switch set

### Dimensions

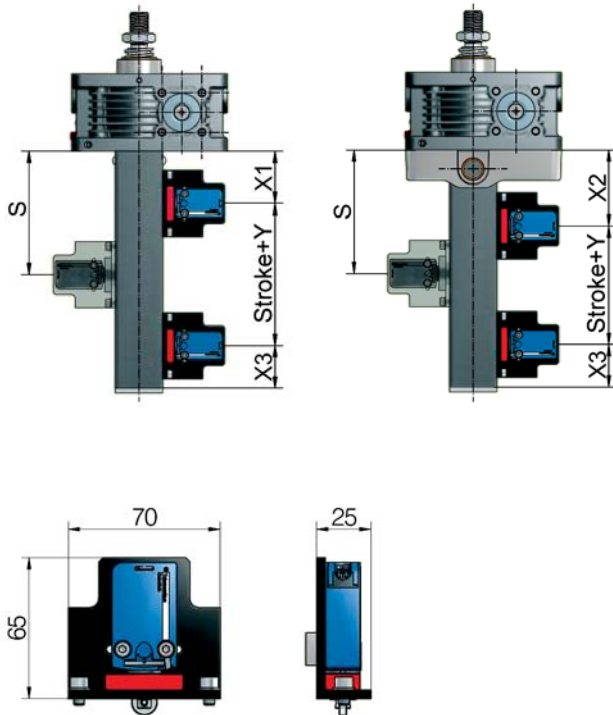

Size	Screw	X1	X2	X3	Y
GSZ-2	Tr 16x4	48	70	48	21
Z-5	Tr 18x4	49	70	45	25
	KGT 16x05, x10	49	70	45	25
Z-10	Tr 20x4	52	72	45	24
	KGT 25x05, x10	52	72	45	24
	KGT 25x25	77	77	68	24
Z-25	KGT 25x50	142	142	133	24
	Tr 30x6	56	80	45	24
Z-35	KGT 32x05, x10, x20	56	80	45	24
	KGT 32x40	91	91	78	24
	Tr 40x7	64	90	45	34
Z-50	Tr 40x7	65	90	45	34
	KGT 40x5, x10, x20	65	90	45	34
	KGT 40x40	90	90	68	34
Z-50/Tr50	Tr 50x8	65	90	45	34
	Tr 55x9	65	110	45	34
Z-100	KGT 50x10	65	110	45	34
	KGT 50x20	70	110	48	34
	KGT 50x40	110	110	88	34
Z-150	Tr 60x9	70	120	45	34
	KGT 63x10	70	120	45	34
	KGT 63x20	75	120	48	34
	KGT 63x40	115	120	88	34
	KGT 63x60	155	155	128	34
Z-250	Tr 80x16	75	-	45	30
	KGT 80x10	75	-	45	30
	KGT 80x20	82	-	50	30
	KGT 80x40	122	-	90	30
	KGT 80x60	162	-	130	30
Z-350	Tr 100x16	85	-	50	31
Z-500	Tr 120x16	102	-	55	40
Z-750	Tr 140x20	110	-	55	40
Z-1000	Tr 160x20	110	-	55	40

### Limit switch position

### Ordering code

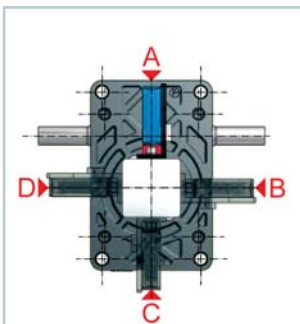

(only A and C permissible for GSZ-2)

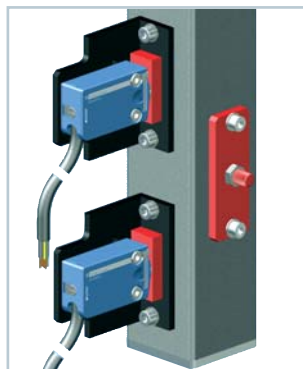

Ordering example:  
1 off Z-25-ES-5-G-A  
1 off Z-25-ES-5-E-A



#### Ordering code for limit switch set:

Ordering code: **Z-25-ES-5-G-A**

Gearbox size  
Cable length  
2m, 5m (standard) or 10m  
Installation  
G = gearbox face (standard)  
E = end of the protective tube (standard)  
S = special position, S = ?? mm  
V = set pre-assembled  
Limit switch position  
A (standard), B, C or D



Datasheet with all technical details on request.

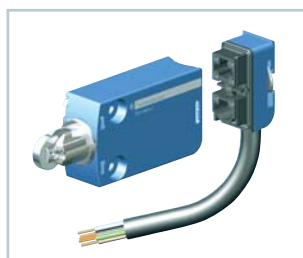

#### Ordering code for an single switch:

Ordering code: **Z-25-ES-5**

Cable length  
2m, 5m or 10m, 0 = without cable

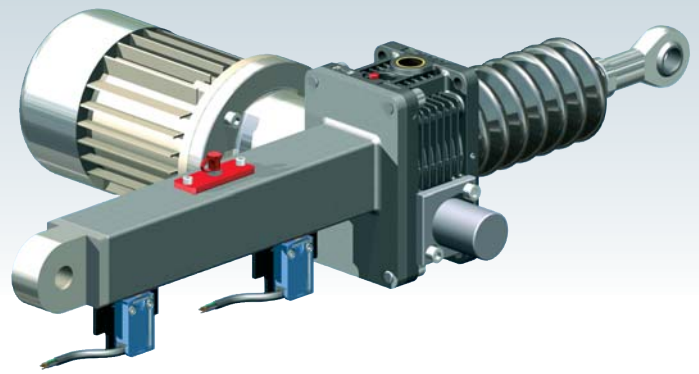

### Pivoting support tube STRO

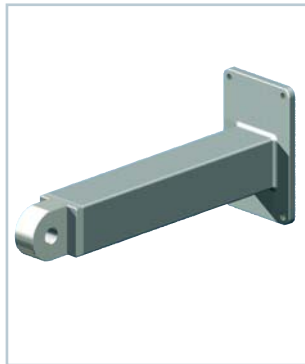

#### Axis of pivoting

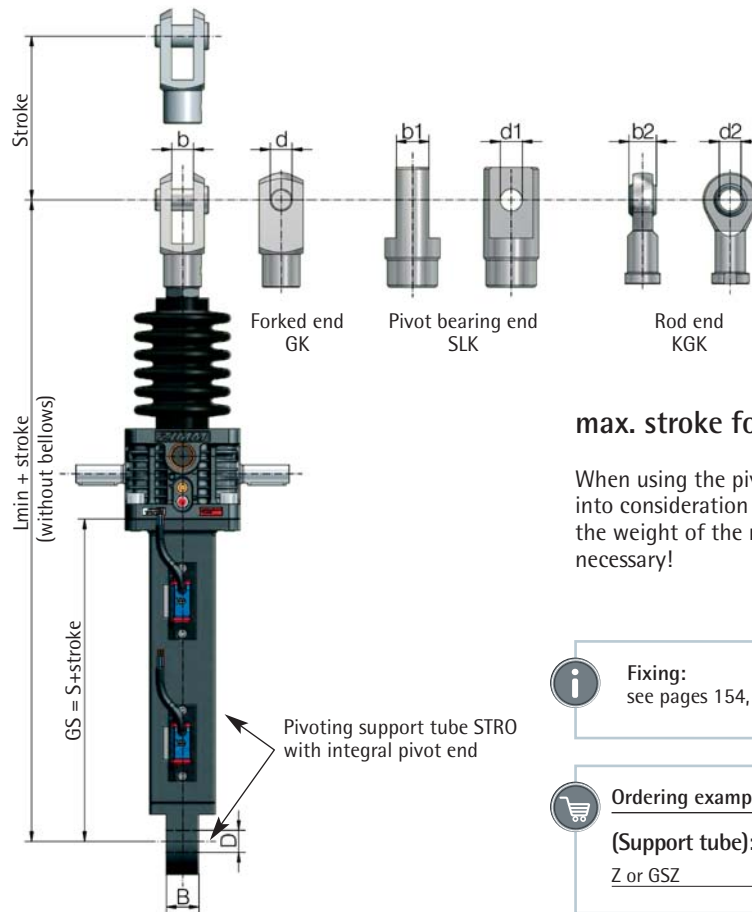
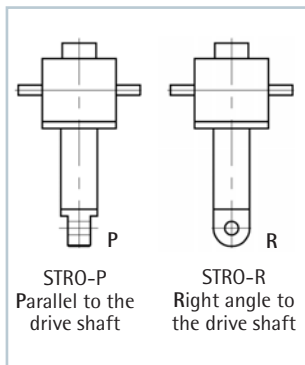

max. stroke for this type: 500 mm!

When using the pivoting support tube, take into consideration the torques arising due to the weight of the motor etc. - support is necessary!

**Fixing:**  
see pages 154, 159

**Ordering example:**  
(Support tube): Z-25-STRO-P, GS=150mm  
Z or GSZ

Size	Options	S	L min. GK	L min. SLK	L min. KGK	d	b	d1	b1	d2	b2	D	B
Z-5	Standard	82	224	224	226	12	12	12	18	12	10	12	20
	with AS/VS	97	239	239	241	12	12	12	18	12	10	12	20
	with ES	155	297	297	299	12	12	12	18	12	10	12	20
Z-10	Standard	94	262	262	267	14	14	14	24	15	12	20	30
	with AS/VS	114	282	282	287	14	14	14	24	15	12	20	30
	with ES	166	334	334	339	14	14	14	24	15	12	20	30
Z-25	Standard	98	303	303	300	20	20	20	30	20	16	20	30
	with AS/VS	118	323	323	320	20	20	20	30	20	16	20	30
	with ES	170	375	375	372	20	20	20	30	20	16	20	30
Z-35	Standard	117	390	362	380	30	30	30	35	30	22	30	35
	with AS/VS	147	420	392	410	30	30	30	35	30	22	30	35
	with ES	203	476	448	466	30	30	30	35	30	22	30	35
Z-50	Standard	137	426	398	416	30	30	30	35	30	22	40	50
	with AS/VS	167	456	428	446	30	30	30	35	30	22	40	50
	with ES	219	508	480	498	30	30	30	35	30	22	40	50
Z-50/Tr50	Standard	137	454	418	452	35	36	35	40	40	28	40	50
	with AS/VS	167	484	448	482	35	36	35	40	40	28	40	50
	with ES	219	536	500	534	35	36	35	40	40	28	40	50
Z-100	Standard	157	539	503	537	35	36	35	40	40	28	40	50
	with AS/VS	187	569	533	567	35	36	35	40	40	28	40	50
	with ES	219	601	565	599	35	36	35	40	40	28	40	50

For a bellows extension, see Section 8 - Length Calculation



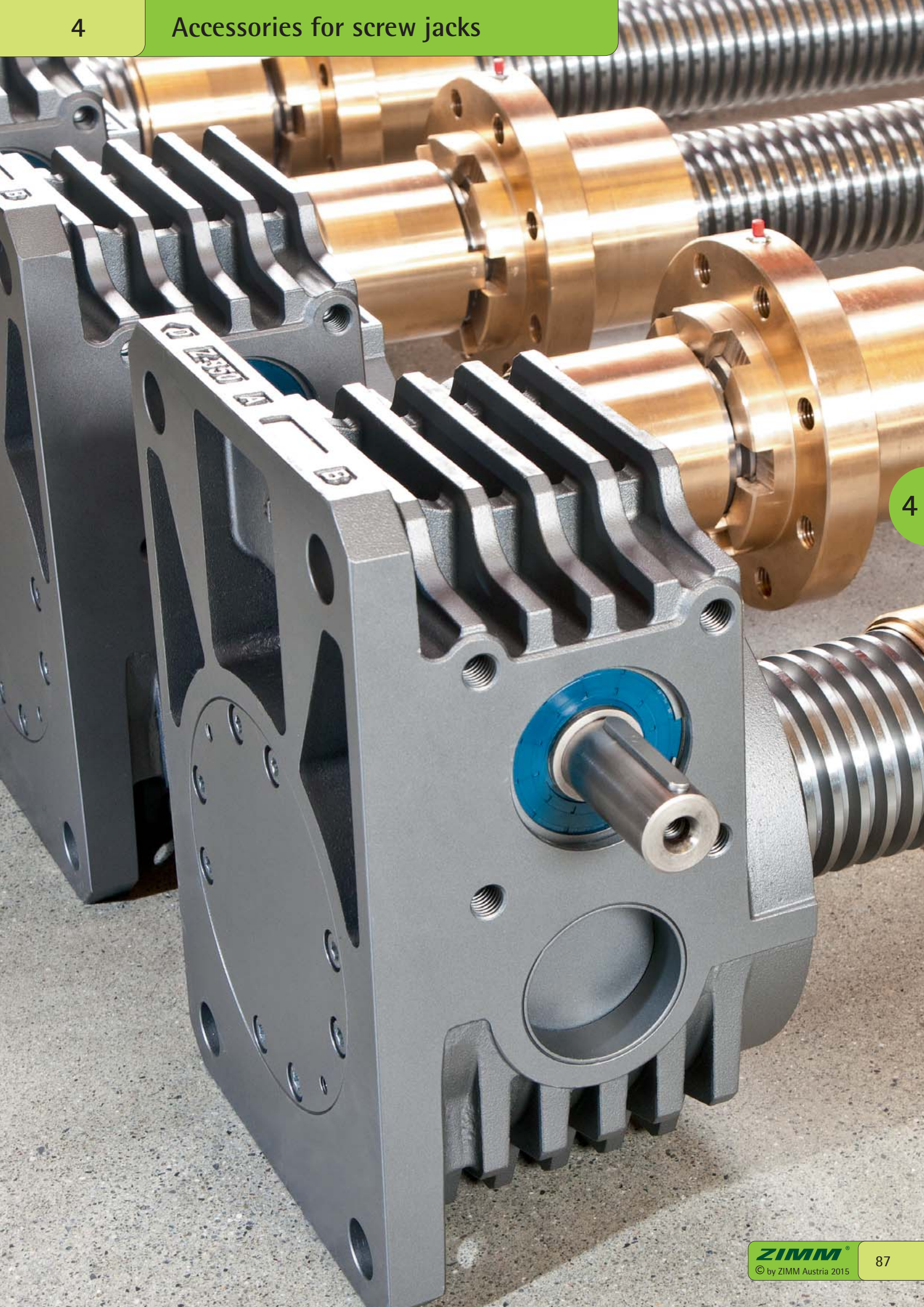

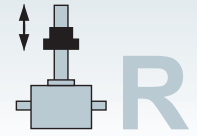

## Nuts for rotating version R

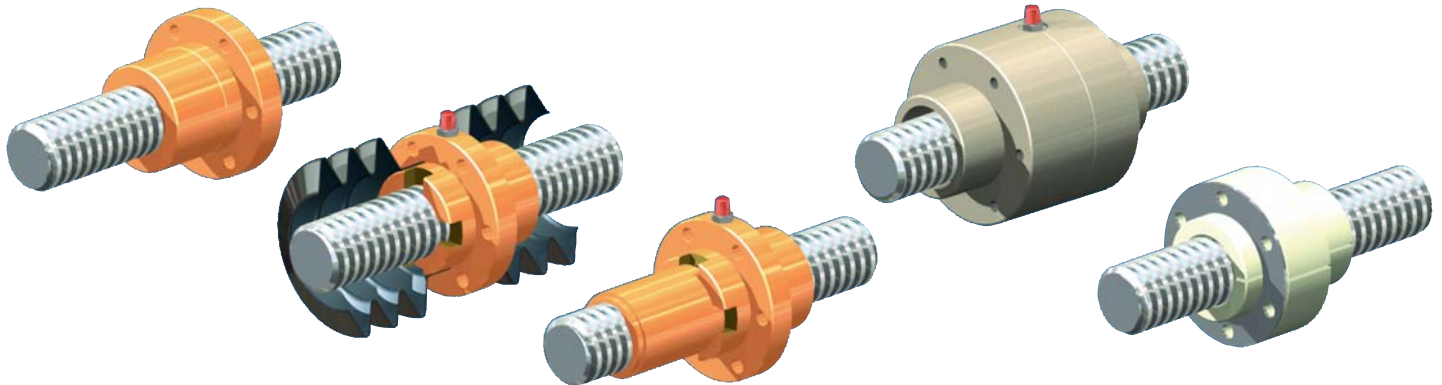

**Flange nut FM**  
Standard nut for simple applications

**Duplex nut DM**  
- Bellows can be attached both sides  
- Uniform  $\varnothing$  on gearbox neck, nut and opposed bearing plate  
- Grease nipple or connection to central lubrication or lubricator

**Safety nut SIFA**  
In combination with duplex nut or self-aligning nut.  
For function and application see Sections 2+3

**Self-aligning nut PM**  
- Angular compensation up to max.  $3^\circ$   
- Bellows can be attached both sides  
- Uniform  $\varnothing$  on gearbox neck, nut and opposed bearing plate  
- Grease nipple or connection to central lubrication or lubricator

**Greaseless nut FFDM**  
- Specially suitable for dry running (such as textiles, foodstuffs, chemicals,...)  
- Bellows can be attached both sides  
- Reinforced with a stainless steel washer



Flange nut Z-..-FM

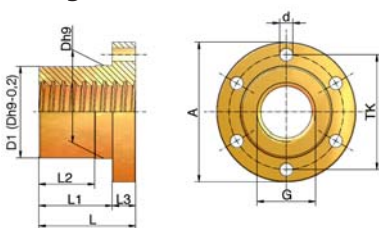

Part no.	G	D1* Dh9	TK	A	d (6x)	L	L1	L2	L3	kg
GSZ-2-FM	Tr 16x4	28	38	48	6	35	23	15	12	0.25
Z-5-FM	Tr 18x4	28	38	48	6	35	23	15	12	0.23
Z-10-FM	Tr 20x4	32	45	55	7	44	32	24	12	0.35
Z-25-FM	Tr 30x6	38	50	62	7	46	32	24	14	0.41
Z-35/50-FM	Tr 40x7	63	78	95	9	66	50	38	16	1.71

Identical to the previous MSZ type  
Material: 2.1090.01 (RG7 bronze)  
Quality: 7H DIN 103  
Right-handed (left-handed, double-pitch on request)

\*D1=Dh9-0.2 mm

Option: Plastic nut  
GSZ-2-FM-K  
Material: High-performance polymer

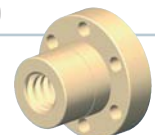

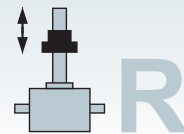

## Nuts for rotating version R

## Duplex nut Z...-DM

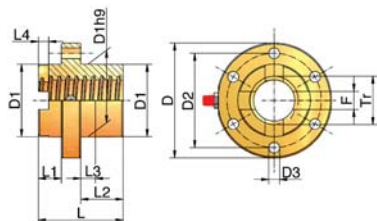

Part no.	Tr	D	D1	D2	D3	L	L1	L2	L3	L4	F	kg
GSZ-2-DM	Tr 16x4	49	26	40 <sup>2)</sup>	5.5 <sup>2)</sup>	45	13	20	8	6	6	0.3
Z-5-DM <sup>1)</sup>	Tr 18x4	52	29	40	6	45	13	20	8	6	6	0.3
Z-10-DM <sup>1)</sup>	Tr 20x4	68	39	54	7	45	13	20	8	6	8	0.57
Z-25-DM <sup>1)</sup>	Tr 30x6	79	46	61	7	50	13	23	8	7	12	0.8
Z-35/50-DM <sup>1)</sup>	Tr 40x7	95	60	78	9	70	18	36	12	8.5	15	1.54
Z-100-DM	Tr 55x9	130	85	108	11	90	18	54	18	10	20	4.1
Z-150-DM	Tr 60x9	140	90	116	13	115	20	75	20	10	20	5.3
Z-250-DM <sup>1)</sup>	Tr 80x16	185	120	153	17	140	25	85	30	14	25	12.2
Z-350-DM <sup>1)</sup>	Tr 100x16	230	145	189	23	160	25	100	35	14	24	21.6
Z-500-DM <sup>1)</sup>	Tr 120x16	255	170	214	23	180	30	110	40	14	30	30.5
Z-750-DM	Tr 140x20	289	200	252	23	220	30	140	50	18	30	58.3
Z-1000-DM <sup>1)</sup>	Tr 160x20	350	250	300	26	320	50	210	70	18	35	155

<sup>1)</sup>Compatible with the previous MSZ type; <sup>2)</sup>only 4 holes  $\varnothing$  5.5 mm

Material: 2.1090.01 (RG7 bronze); quality: 7H DIN 103

Right-handed (left-handed, double-pitch on request)

Threaded grease nipple, up to Z-50 G1/8", from Z-100 G1/4"

## Safety nut Z...-SIFA-R

see also Sections 2+3

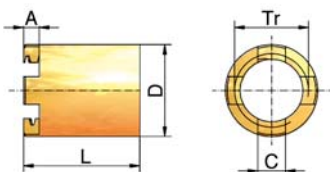
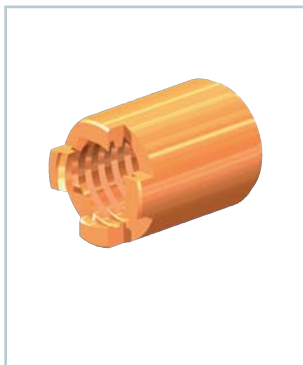

Part no.	Tr	A	C	D	L	kg
GSZ-2-SIFA-R	Tr 16x4	6	6	22	28	0.05
Z-5-SIFA-R <sup>1)</sup>	Tr 18x4	6	6	24	28	0.05
Z-10-SIFA-R <sup>1)</sup>	Tr 20x4	6	8	28	42	0.11
Z-25-SIFA-R <sup>1)</sup>	Tr 30x6	7	12	38	47.5	0.20
Z-35/50-SIFA-R <sup>1)</sup>	Tr 40x7	8.5	15	50	67	0.46
Z-100-SIFA-R	Tr 55x9	10	20	65	87	1.10
Z-150-SIFA-R	Tr 60x9	10	20	70	100	1.20
Z-250-SIFA-R <sup>1)</sup>	Tr 80x16	14	25	100	115	3.30
Z-350-SIFA-R <sup>1)</sup>	Tr 100x16	14	24	120	115	4.07
Z-500-SIFA-R <sup>1)</sup>	Tr 120x16	14	30	135	128	6.02
Z-750-SIFA-R <sup>1)</sup>	Tr 140x20	18	30	170	151	13.8
Z-1000-SIFA-R <sup>1)</sup>	Tr 160x20	18	35	190	186	19.8

<sup>1)</sup>Compatible with the previous MSZ type

Material: RG7

## Cardan adapters DMA

for duplex nuts DM

see pages 154, 159

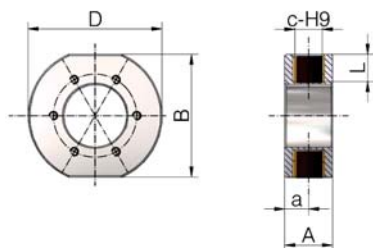

Part no.	B	D	c-H9	L	A	a	kg
Z-5-DMA	72	78	16	15	30	15	1.0
Z-10-DMA	72	78	16	15	30	15	0.9
Z-25-DMA	90	98	20	20	36	18	1.4
Z-35-DMA	100	116	28	15	46	23	2.3
Z-50-DMA	100	116	30	15	46	23	2.3
Z-100-DMA	140	156	40	25	60	30	4.8
Z-150-DMA	145	160	50	25	76	38	6.8
Z-250-DMA	185	206	60	30	90	45	12.7

Material: Steel, corrosion-resistant; pivot bearing: Bronze, PTFE coated

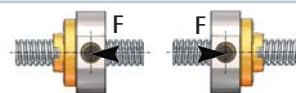

## Main direction of loading

Select the main direction of loading so that tensile loads on the nut are avoided

## Driving flange TRMFL

for flange nut Z...-FM

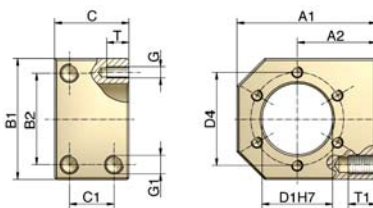
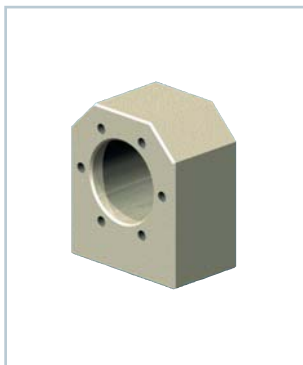

Part no.	for FM	A1	A2max*	A2min*	B1	B2
TRMFL-18x4**	Tr 18x4**	60	35.0	25.0	50	34
TRMFL-20x4	Tr 20x4	68	37.5	29.0	58	39
TRMFL-30x6	Tr 30x6	75	42.5	32.5	65	49
TRMFL-40x7	Tr 40x7	120	70.0	50.0	100	76

Part no.	C	C1	G1	D1	D4	GxT	kg
TRMFL-18x4	40	24	M8x15	28	38	M5x10	0.7
TRMFL-20x4	40	24	M8x15	32	45	M6x12	0.9
TRMFL-30x6	40	24	M10x15	38	50	M6x12	1.1
TRMFL-40x7	65	41	M14x25	63	78	M8x14	4.5

\* Supplied ex-works with size A2max.

Can be machined by the customer to A2min.

\*\* Suitable also for GSZ-2-FM (Tr 16x4)

Material: steel, corrosion-resistant

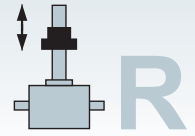

## Nuts for rotating version R



### Self-aligning nut Z-...-PM

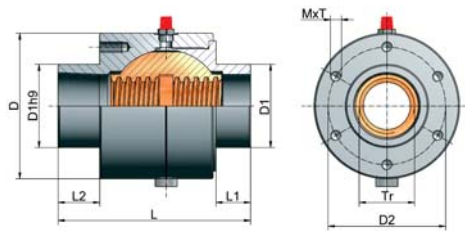

#### Advantage

- Angular compensation up to  $\pm 3^\circ$
- Grease nipple or connection thread to central lubrication
- Bellows can be connected

#### Application:

(Welded) fabrications often exhibit angular errors, which lead to rapid wear of the trapezoidal screw nuts. The self-aligning nut PM can compensate small angular errors on the attachment face up to maximum  $\pm 3^\circ$ . A large grease reservoir increases the maintenance intervals and extends the service life.

#### CAUTION:

Self-aligning nuts cannot compensate parallelism errors between screws or between screws and guides. Take care to ensure precise alignment. The attachment faces for the gearboxes must therefore be exactly at right angles to the guides.

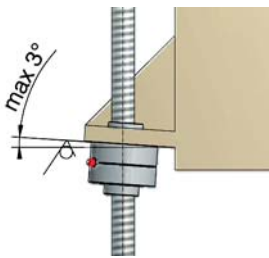

Part no.	Thread Tr d x P	D	D1	D2
Z-5-PM <sup>1)</sup>	Tr 18x4	52	29	40
Z-10-PM <sup>1)</sup>	Tr 20x4	74	39	60
Z-25-PM <sup>1)</sup>	Tr 30x6	88	46	70
Z-35/50-PM <sup>1)</sup>	Tr 40x7	105	60	85
Z-100-PM	Tr 55x9	148	85	120
Z-150-PM	Tr 60x9	165	90	125
Z-250-PM	Tr 80x16	225	120	170
Z-350-PM	Tr 100x16	280	145	215

Part no.	M x T	L	L1	L2	LS <sup>2)</sup>	kg
Z-5-PM <sup>1)</sup>	M5x12	78	13	21	123	0.66
Z-10-PM <sup>1)</sup>	M6x12	83	13	24	128	1.49
Z-25-PM <sup>1)</sup>	M6x12	95	13	27	158	2.36
Z-35/50-PM <sup>1)</sup>	M8x16	129	15	30	212	5.04
Z-100-PM	M10x20	190	15	45	298	15.1
Z-150-PM	M12x24	210	15	45	330	21.9
Z-250-PM	M16x32	224	20	40	369	47.0
Z-350-PM	M20x40	275	20	40	455	94

<sup>1)</sup>Identical to the previous MSZ type

<sup>2)</sup>Overall length PM incl. SIFA safety nut

#### Trapezoidal screw

DIN 103, quality 7H, right-handed

#### Screwed grease nipple

Thread 1/8" / 1/4" from Tr 40x7

#### Material

Housing: GG 25 (grey cast iron)

Spherical nut: Rg7 (bronze)

#### Safety nut SIFA

is available for the self-aligning nut on request.

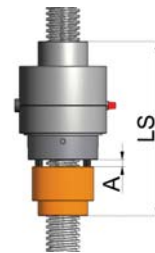

### Greaseless nut Z-...-FFDM

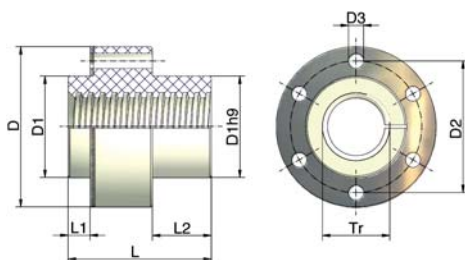
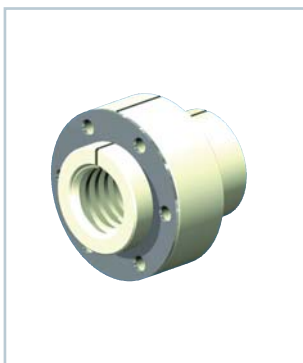

Part no.	Tr	D	D1 <sup>3)</sup>	D2	D3	L	L1	L2	kN max. Load <sup>2)</sup>	kg
Z-5-FFDM <sup>1)</sup>	Tr 18x4	52	29	40	6	53	11	20	1	0.07
Z-10-FFDM <sup>1)</sup>	Tr 20x4	68	39	54	7	53	11	20	2	0.12
Z-25-FFDM <sup>1)</sup>	Tr 30x6	79	46	61	7	59	11	23	5	0.18
Z-35/50-FFDM <sup>1)</sup>	Tr 40x7	95	60	78	9	85	13	35	7	0.38

Nut material: Plastic, high-performance polymer  
Steel ring material: stainless steel

Quality: 7H DIN 103, right-handed

<sup>1)</sup>Identical to the previous MSZ - FFDM type

<sup>2)</sup>As approximate value, depending on the stroke speed and ambient temperature

<sup>3)</sup>Connection bore for D1 +0.2 mm for thermal expansion

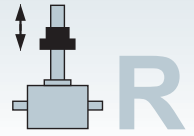

## For rotating screw R



## Trapezoidal screw Z-.-R-Tr

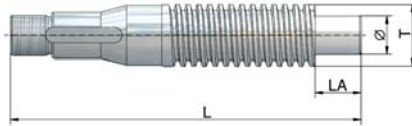

Material: C35 or Ck45 (stainless steel on request)  
 Quality: DIN 103, 7e rolled, from Tr 80 whirled  
 Pitch accuracy 0.2 mm / 300 mm  
 Right-handed (double-pitch, left-handed on request)

Part no.	Tr	Ø	LA	kg/m
GSZ-2-R-Tr	Tr 16x4	10j6	12	1.2
Z-5-R-Tr	Tr 18x4	12j6	15	1.6
Z-10-R-Tr	Tr 20x4	15j6	20	2.0
Z-25-R-Tr	Tr 30x6	20j6	25	4.5
Z-35-R-Tr	Tr 40x7	25j6	30	8.0
Z-50-R-Tr	Tr 40x7	25j6	30	8.0
Z-100-R-Tr	Tr 55x9	40j6	45	16
Z-150-R-Tr	Tr 60x9	45j6	55	19
Z-250-R-Tr	Tr 80x16	60j6	75	32
Z-350-R-Tr	Tr 100x16	80j6	100	52
Z-500-R-Tr	Tr 120x16	95j6	120	77
Z-750-R-Tr	Tr 140x20	100j6	120	105
Z-1000-R-Tr	Tr 160x20	130j6	175	139



## Opposed bearing plate GLP

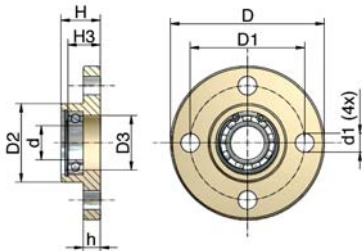

Material: Steel, corrosion-resistant  
 Hard anodised aluminium (GSZ-2-GLP)  
 Up to Z-150 stainless steel bearings  
 The ball bearing is already fitted at delivery  
 Identical to the previous MSZ type

Part no.	ØD	ØD1	ØD2	ØD3	Ød	Ød1
GSZ-2-GLP	50	40	26	19	10	5.5
Z-5-GLP	65	48	29	20	12	9
Z-10-GLP	80	60	39	28	15	11
Z-25-GLP	90	67	46	32	20	11
Z-35/50-GLP	110	85	60	42	25	13
Z-100-GLP	150	117	85	60	40	17
Z-150-GLP	170	130	90	68	45	21
Z-250-GLP	210	165	120	85	60	26
Z-350-GLP	265	205	145	95	80	26
Z-500-GLP	310	240	170	130	95	38
Z-750-GLP	350	280	200	168	100	6x32

Part no.	h	H	H3	Lager	Si ring	kg
GSZ-2-GLP	6	16	12	61900.2RS	J 22	0.05
Z-5-GLP	7	20	13	61901.2RS	J 24	0.17
Z-10-GLP	8	21	17	6002.2RS	J 32	0.30
Z-25-GLP	10	23	19	61904.2RS	J 37	0.48
Z-35/50-GLP	15	30	22	6005.2RS	J 47	1.05
Z-100-GLP	20	50	35	6008.2RS	J 68	3.10
Z-150-GLP	25	50	31	6009.2RS	J 75	3.70
Z-250-GLP	30	60	50	2x6012.2RS	J 95	6.90
Z-350-GLP	32	65	54	2x6016.2RS	J125	11.50
Z-500-GLP	40	100	60	2x6019.2RS	J145	24.00
Z-750-GLP	40	100	83	2x6020.2RS	J180	32.00

The opposed bearing plate increases the smoothness of operation and the resistance of the screw to buckling.  
 Allow 5 mm at the end of the screw for length compensation.

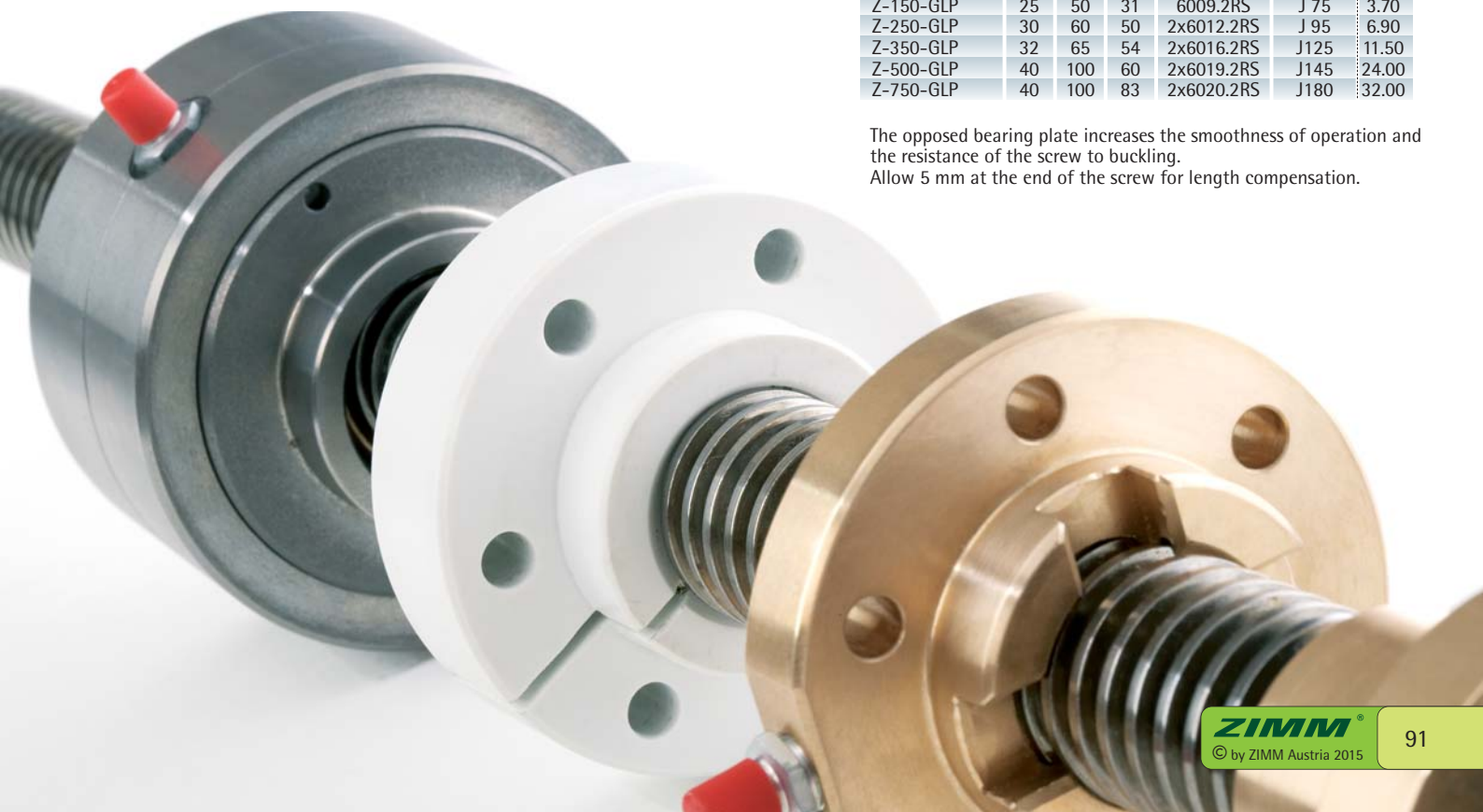

## Fitting the bellows

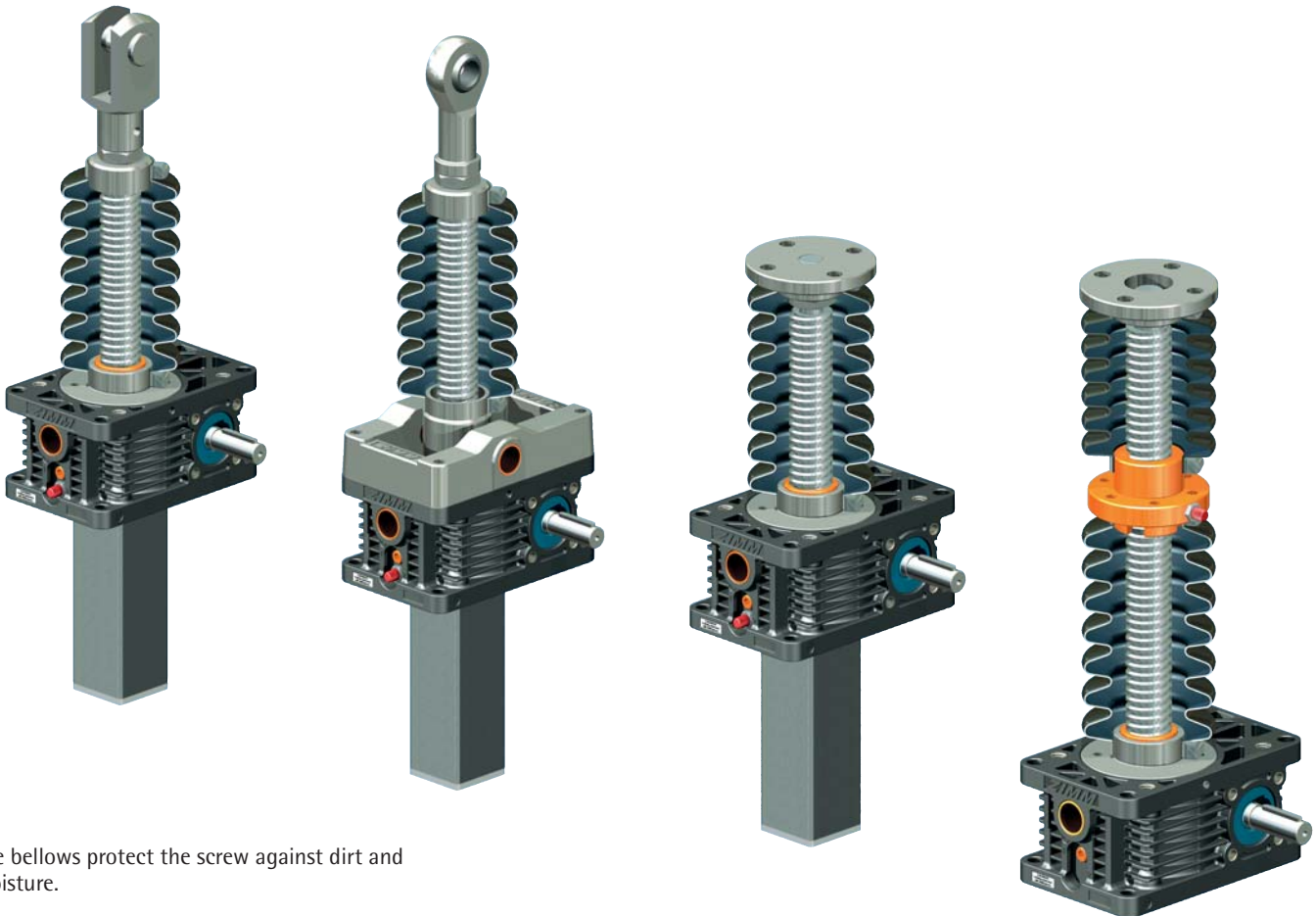

The bellows protect the screw against dirt and moisture.

### PLEASE NOTE:

The bellows must not be compressed to less than the ZD dimension nor extended beyond the AZ dimension.

If the stroke is longer than 1000 mm, fit a bellows with an extension block. Take into consideration that when the bellows is fitted

horizontally it must not touch the screw: Risk of serious damage! Use support rings to avoid such damage.

Protect the screws, especially during on-site assembly, against: building site dust, grinding dust from angle grinders,

weld spatter, etc. Protect the bellows against direct sunshine.

Take into consideration also that the thermal insulation effect of the bellows reduces the maximum duty cycle of the screw jack.



### Bellows Z-...-FB, round

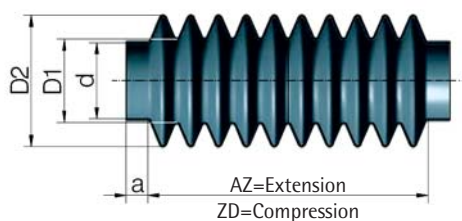

Part no.		a	d	ZD	AZ	Stroke	D1	D2	kg
GSZ-2-FB 182		11	26	38	220	182	26	55	0.08
GSZ-2-FB 364		11	26	98	462	364	26	55	0.16
Z-5-FB-265		10	29	35	300	265	40	76	0.15
Z-10-FB-340		10	39	80	420	340	40	80	0.21
Z-25-FB-300		15	46	70	370	300	50	83	0.25
Z-35/50-FB-390		18	60	85	475	390	66	102	0.43
Z-100-FB-285		15	85	75	360	285	85	118	0.29
Z-150-FB-350		15	90	50	400	350	92	141	0.44
Z-250-FB-390		15	120	90	480	390	125	166	1.10
Z-350-FB-600		15	145	100	700	600	172	236	2.40

Material: PVC, NBR (GSZ-2), operating temperature  $-20^{\circ}\text{C}$  to  $+70^{\circ}\text{C}$  (max.  $+85^{\circ}\text{C}$ ), cold fracture temperature  $-32^{\circ}\text{C}$ , incl. 2 galvanised hose clips.

**CAUTION:** For screw extensions, see Sections 2+3 identical to the previous MSZ type

## Bellows FB

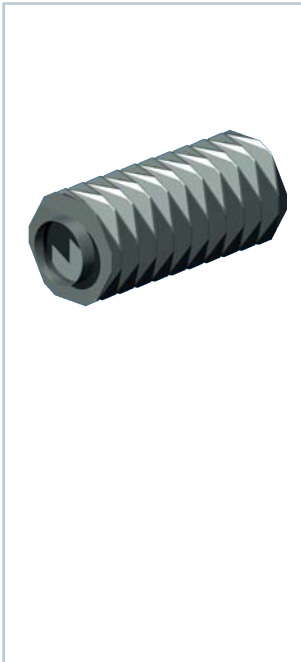

## Bellows Z-..-FB, polygonal

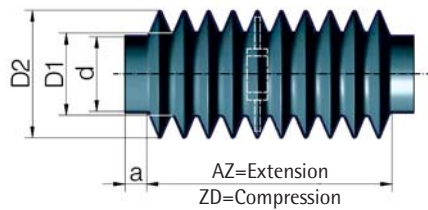

Material: Polyurethane-coated polyester fabric type OZ-23, temperature stability -15°C to +70°C, incl. 2 galvanised hose clips.

For screw extensions, see Sections 2+3

**CAUTION:**  
For special bellows, dimensions ZD, AZ and DZ may be different!

Part no.	a	d	ZD	AZ	Stroke	D1	D2	kg
Z-5-FB-500	10	29	100	600	500	38	68	0.19
Z-5-FB-800	10	29	120	920	800	38	68	0.30
Z-10-FB-700	10	39	100	800	700	38	75	0.23
Z-10-FB-1000	10	39	150	1150	1000	38	75	0.32
Z-25-FB-700	15	46	100	800	700	63	105	0.32
Z-25-FB-1000	15	46	120	1120	1000	63	105	0.43
Z-35/50-FB-600	15	60	72	672	600	63	105	0.23
Z-35/50-FB-1000	15	60	130	1130	1000	63	105	0.42
Z-35/50-FB-1200	15	60	125	1325	1200	63	105	0.42
Z-35/50-FB-1500	15	60	180	1680	1500	63	105	0.51
Z-100-FB-600	15	85	72	672	600	63	105	0.29
Z-100-FB-1000	15	85	130	1130	1000	63	105	0.40
Z-100-FB-1500	15	85	180	1680	1500	63	105	0.44
Z-150-FB-600	15	90	72	672	600	110	150	0.40
Z-150-FB-1000	15	90	130	1130	1000	110	150	0.60
Z-150-FB-1500	15	90	180	1680	1500	110	150	0.82
Z-250-FB-600	15	120	72	672	600	110	150	0.40
Z-250-FB-1000	15	120	130	1130	1000	110	150	0.60
Z-250-FB-1500	15	120	180	1680	1500	110	150	0.82
Z-350-FB-900	15	145	108	1008	900	150	200	0.70
Z-350-FB-1500	15	145	180	1680	1500	150	200	1.10

**IMPORTANT!** When ordering, please specify:  
When mounted horizontally, the bellows must be fitted with suitable support rings, so as to avoid wear due to rubbing against the trapezoidal thread of the screw.  
For lengths longer than 1000 mm, an extension block is necessary.  
Compatible with the previous MSZ types

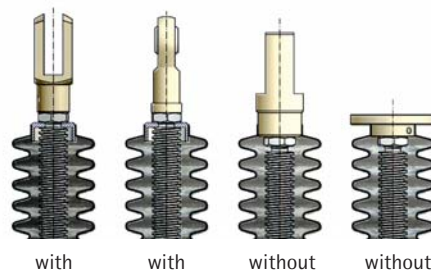
Bellows fixing ring  
Z-..-FBR

The fixing ring FBR is used to secure the bellows FB to the forked end GK or rod end KGK. Identical to the previous MSZ types

If a forked end GK or rod end KGK is included in the scope of the order, the fixing ring is supplied automatically.  
Otherwise, please order it separately.

**Ordering example:**  
Z-25-FBR

Material: POM (plastic)

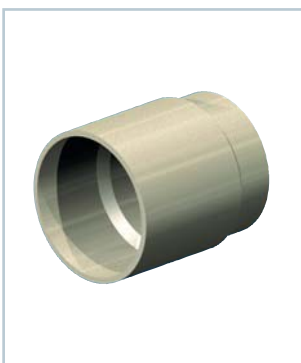

## Bellows adapter Z-..-FBA

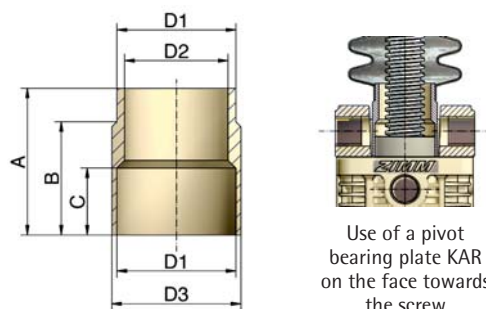

Part no.	D1	D2	D3	A	B	C
Z-5-FBA	29	25	32	44	32	20
Z-10-FBA	39	30	42	42	32	22
Z-25-FBA	46	40	50	57	42	26
Z-35/50-FBA	60	52	65	70	52	40
Z-100-FBA	85	80	90	90	72	50
Z-150-FBA	90	85	95	100	82	50
Z-250-FBA	120	115	125	118	100	60
Z-350-FBA	145	140	150	130	112	60
Z-500-FBA	170	150	180	172	152	70

Material: Aluminium, corrosion-resistant

## Spiral spring attachment



Spiral spring cover attachment for types SN/SL

Spiral spring cover attachment for types RN/RL

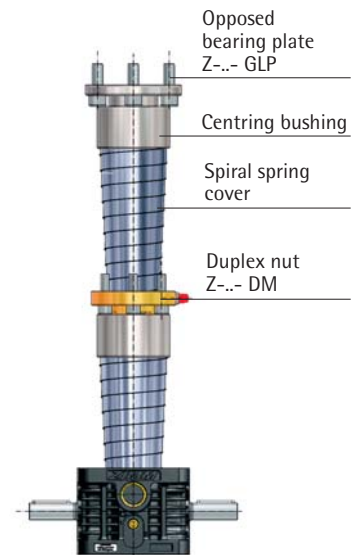
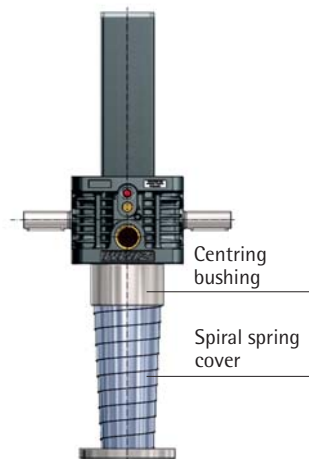
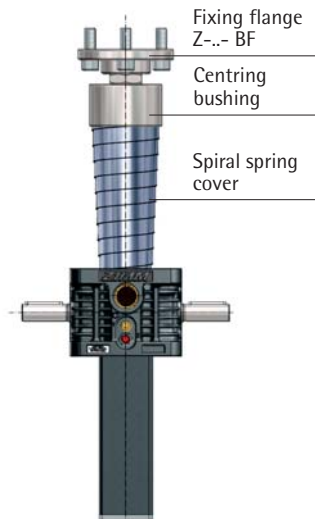
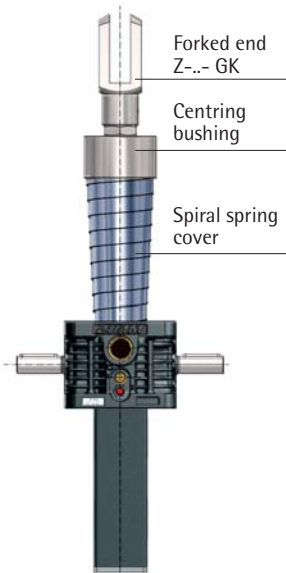

### Fitting instructions:

Spiral springs can be used on chip-generating and non-chip generating machines.

The illustrations show how to fit different types of spiral spring covers to various screw jacks.

Centring bushings are required when assembling combinations of different parts; we can include these in our quotation on request.

### IMPORTANT:

Spiral springs must under no circumstances be allowed to uncoil. For technical reasons, please specify in your enquiry whether the spiral spring is to be installed horizontally or vertically.

If installation is to be vertical, we recommend that the larger diameter is at the top,

as shown; if it is to be horizontal, the taper should be away from the direction of flow of the chips or other particulate.

A slight film of oil on the spiral spring improves its operation and extends its service life.



## Spiral spring cover SF

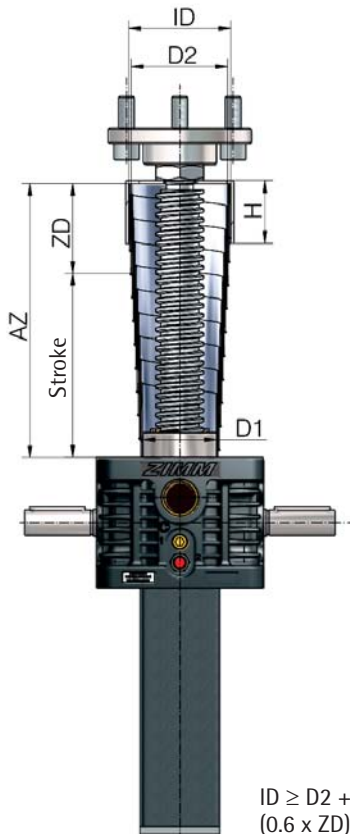

$ID \geq D2 + 4 \text{ mm}$   
 $(0.6 \times ZD) \leq H \leq (ZD - 2 \text{ mm})$

**Material:**

SF: Spring band steel, blued (on request we can also supply versions in stainless steel)

Centring bushing: Plastic (other materials on request)

**CAUTION:**

The spring travel quoted is the maximum possible. For practical operation, please allow a margin of safety to prevent damage! We recommend preparation of a drawing to determine the fitting position and dimensions of spiral springs.

**Ordering example:**

SF-030-0450-030-H      SFZ-ID57-H20

Spiral spring  
 Least diameter D1  
 Greatest length AZ\*  
 Least length ZD  
 H=horizontal installation  
 V=vertical installation

Centring bushing  
 Inner diameter  
 Height

Screw jack Z-5						Bushing			
Type SF	D1	D2	ZD	Stroke	kg	ID	AD	H	
030-0450-030-V	30	53	30	420	0.30	57	61	20	
030-0450-030-H	30	53	30	360	0.30	57	61	20	

Screw jack Z-10						Bushing			
Type SF	D1	D2	ZD	Stroke	kg	ID	OD	H	
040-0450-040-V	40	64	40	410	0.53	69	73	30	
040-0450-040-H	40	64	40	350	0.53	69	73	30	
040-0900-060-V	40	70	60	840	1.09	74	78	36	
040-0900-060-H	40	70	60	720	1.09	74	78	36	
040-1300-075-V	40	84	75	1225	2.20	88	92	50	
040-1300-075-H	40	84	75	1075	2.20	88	92	50	

Screw jack Z-25						Bushing			
Type SF	D1	D2	ZD	Stroke	kg	ID	OD	H	
050-0450-050-V	50	70	50	400	0.64	74	78	36	
050-0450-050-H	50	70	50	300	0.64	74	78	36	
050-0750-060-V	50	80	60	690	1.07	84	88	40	
050-0750-060-H	50	80	60	570	1.07	84	88	40	
050-1200-075-V	50	94	75	1125	2.45	98	104	50	
050-1200-075-H	50	94	75	975	2.45	98	104	50	
050-1500-100-V	50	88	100	1400	2.70	92	96	60	
050-1500-100-H	50	88	100	1200	2.70	92	96	60	

Screw jacks Z-35, Z-50						Bushing			
Type SF	D1	D2	ZD	Stroke	kg	ID	OD	H	
065-0450-050-V	65	88	50	400	0.64	92	96	35	
065-0450-050-H	65	88	50	300	0.64	92	96	35	
065-1100-075-V	65	107	75	1025	2.50	112	118	60	
065-1100-075-H	65	107	75	825	2.50	112	118	60	
065-1500-100-V	65	108	100	1400	3.80	112	118	60	
065-1500-100-H	65	108	100	1200	3.80	112	118	60	
065-2100-120-V	65	113	120	1980	5.65	118	124	80	
065-2100-120-H	65	113	120	1740	5.65	118	124	80	

Screw jack Z-50/Tr50, Z-100						Bushing			
Type SF	D1	D2	ZD	Stroke	kg	ID	AD	H	
090-0650-075-V	90	124	75	575	2.80	128	134	50	
090-0650-075-H	90	124	75	425	2.80	128	134	50	
090-1300-100-V	90	132	100	1200	4.90	136	142	60	
090-1300-100-H	90	132	100	1000	4.90	136	142	60	

Screw jack Z-150						Bushing			
Type SF	D1	D2	ZD	Stroke	kg	ID	AD	H	
100-0800-075-V	100	138	75	725	3.70	143	149	51	
100-0800-075-H	100	138	75	575	3.70	143	149	51	
100-1500-100-V	100	146	100	1400	6.00	150	156	75	
100-1500-100-H	100	146	100	1200	6.00	150	156	75	



Other sizes of spiral springs are available on request.

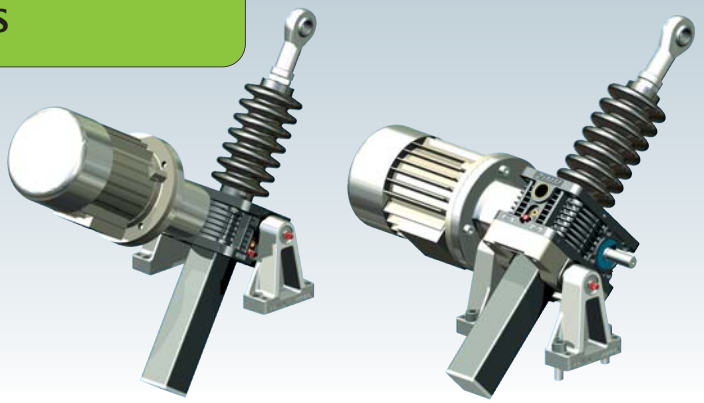

Pivoting – Z-5 to Z-25

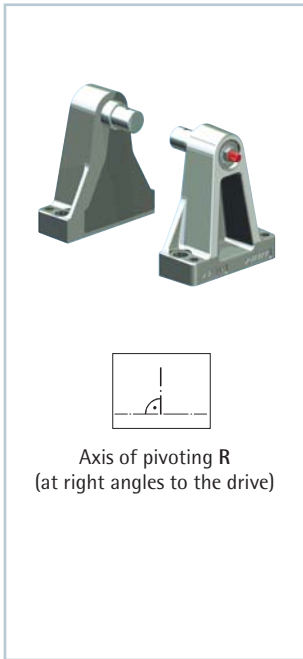

Pivot mounts LB

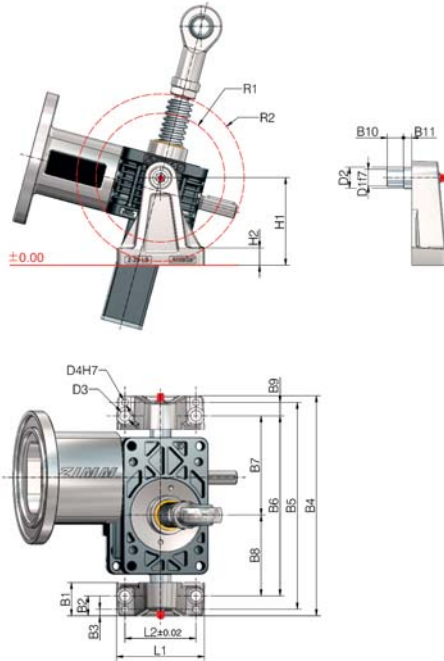

Dimensions	B1	B2	B3	B4	B5	B6	B7	B8	B9	B10	B11
Z-5 (Z-5/10-LB)	40	25	10	200	180	150	84	66	15	15	6
Z-10 (Z-5/10-LB)	40	25	10	220	200	170	95	75	15	15	6
Z-25 (Z-25-LB)	40	24	08	264	248	216	119	97	16	20	10

Dimensions	D1	D2	D3	D4	H1	H2	L1	L2	R1	R2	kg (set)
Z-5 (Z-5/10-LB)	16	22	11	8	80	18	90	70	57	63	0.72
Z-10 (Z-5/10-LB)	16	22	11	8	80	18	90	70	68	74	0.72
Z-25 (Z-25-LB)	20	25	13	8	105	21	105	85	78	100	1.30

Integrated pivot bearing

Simple and economical design:  
Pivot bushes are incorporated in the gearbox housing.

Lubrication

The bronze bushes are PTFE-coated and therefore require no lubrication in normal service. We recommend regular lubrication for high loadings.

Design tip

For large motors, long strokes and high load cycles, the variant with the pivot bearing plate KAR is preferable, because the weight of the motor is then taken by the pivoting points and does not affect the screw.

**i** **F** Refer to the permissible loads listed in Section 8

Material: Aluminium, corrosion-resistant  
Bolt: Stainless steel

**Part no.:**  
Z-5/10-LB set (2 items)  
Z-25-LB set (2 items)

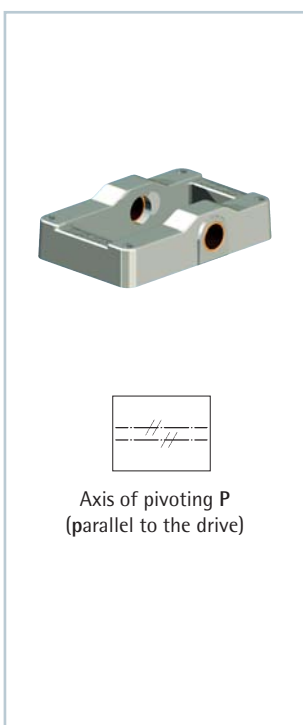

Pivot bearing plate KAR

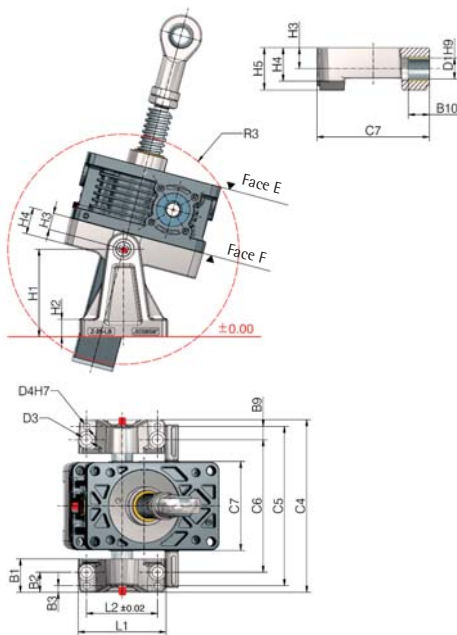

Dimensions	B1	B2	B3	B9	B10	C4	C5	C6	C7	D1	D3
Z-5-KAR	40	25	10	15	15	166	146	116	74	16	11
Z-10-KAR	40	25	10	15	15	179	159	129	87	16	11
Z-25-KAR	40	24	08	16	20	207	191	159	107	20	13

Dimensions	D4	H1	H2	H3	H4	H5	L1	L2	R3	kg
Z-5-KAR	8	80	18	15	21	30	90	70	100	0.24
Z-10-KAR	8	80	18	15	24	30	90	70	116	0.33
Z-25-KAR	8	105	21	20	32	40	105	85	138	0.80

Multi-jack systems

The KAR pivot bearing plate allows several jacks to be arranged in a row.

Lubrication

The bronze bushes are PTFE-coated and therefore require no lubrication in normal service. We recommend regular lubrication for high loadings.

**Part no.:**  
Z-5-KAR  
Z-10-KAR  
Z-25-KAR

Please specify: mounted on face E or face F

Example: 2-jack system

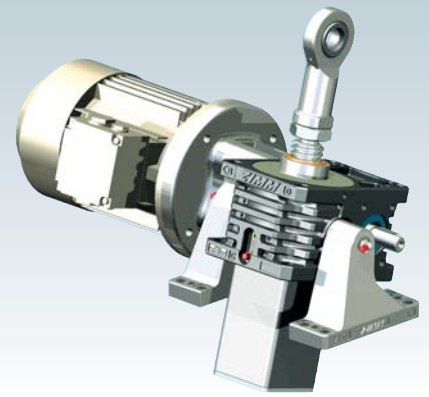

## Pivoting – Z-35 to Z-1000

### Pivot mounts LB

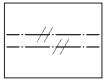
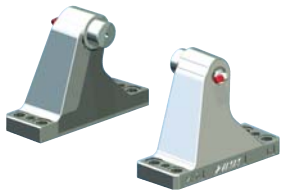

Axis of pivoting P  
(parallel to the drive)

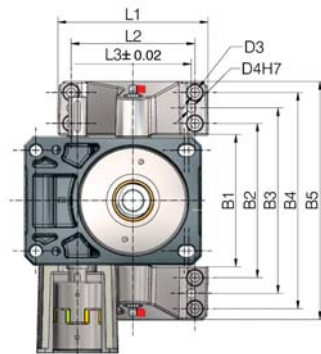
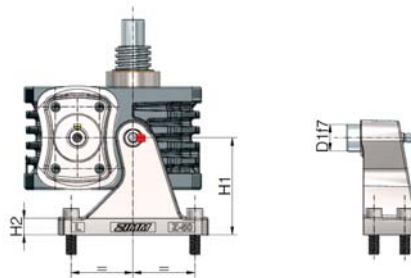

Material: Cast steel, quenched and tempered, corrosion-resistant

From Z-500 the gearbox is mounted the opposite way round, since the footplate is broader than the rest of the housing:



Dimensions	D1	D3	D4	H1	H2	L1	L2
Z-35-LB	28	11	8	85	18	130	106
Z-50-LB	30	13	10	110	18	170	140
Z-100-LB	40	22	20	120	22	260	180
Z-150-LB	50	22	20	135	24	280	200
Z-250-LB	60	26	20	170	32	285	230
Z-350-LB	80	33	25	210	36	380	310

Dimensions	L3	B1	B2	B3	B4	B5	kg (set)
Z-35-LB	106	124	146	174	202	224	3.2
Z-50-LB	140	150	175	210	245	270	5.0
Z-100-LB	225	210	250	290	330	370	11.8
Z-150-LB	235	222	262	312	362	402	18.0
Z-250-LB	220	265	325	400	475	535	31
Z-350-LB	300	302	372	462	552	622	66

### Integrated pivot bearing

Simple and economical design:

Pivot bushes are incorporated in the gearbox housing.

### Lubrication

The bronze bushes are PTFE-coated and therefore require no lubrication in normal service. We recommend regular lubrication for high loadings.

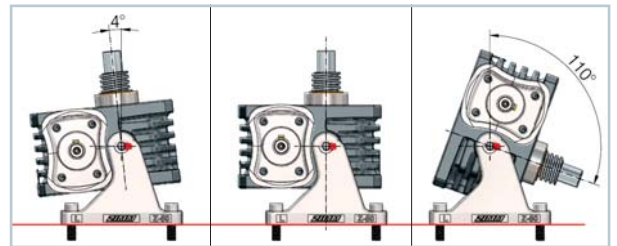

Refer to the permissible loads listed in Section 8



Part no.:

Z-50-LB set  
(1x right-handed, 1x left-handed)

### Pivot bearing plate Z-35-KAR

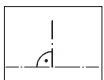
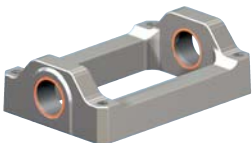

Axis of pivoting R  
(at right angles to the drive)

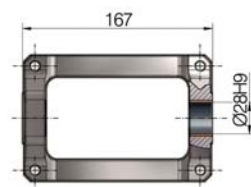

Material: GGG-50

### Pivot bearing plate from Z-35

The use of the pivot mounts LB directly within the gearbox housing is the best and most economical solution. Design considerations may in some cases necessitate the use of a pivot bearing plate.

Other sizes of pivot arrangements "R" and "P" are available on request.



Part no.:

Z-35-KAR

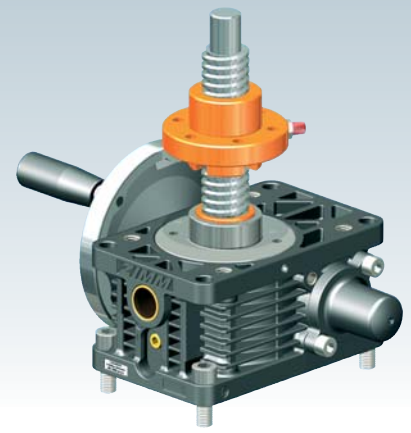

For the S and R version

Handwheel HR

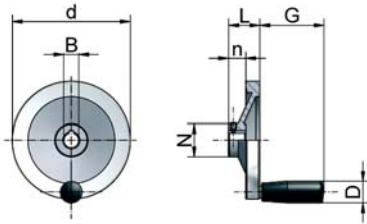

Part no.	d	N	b	n	L	G	D	B H7	B H7	kg
HR-80	80	26	13.0	16	26	42.5	18	8	9/11	0.16
HR-125	125	31	15.0	18	33	67.5	23	6	11/14	0.30
HR-160	160	36	18.0	20	39	82.5	26	14	14/16/19	0.50
HR-200	200	42	20.5	24	45	82.5	26	16	16/19/20	1.00
HR-250	250	48	23.0	28	51	92.5	28	20	20/25	1.30

Material: Aluminium, plastic (handle)  
Design: No more than max. 50 - 60 N force should be required at the handle



Ordering example:

Diameter  
Bore  
N = with keyway and set screw  
V = only pilot hole

HR-125-11-N

Protective cap GSZ-2-SK



GSZ-2

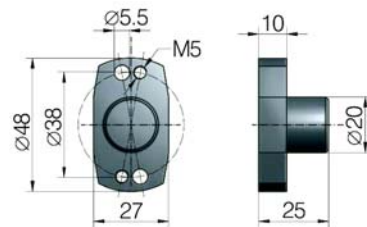

incl. screws  
Material: Hard anodised aluminium

Part no.	D	d	E	F	Screws DIN 912	kg
GSZ-2-SK	20	5.5/M5	25	10	M5x55	0.05

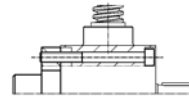

M5x55  
Screws are included with the protective cap

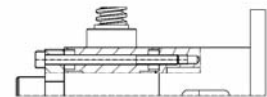

M5x70  
Screws are included with the motor flange / bevel gearbox

Protective cap Z-- SK



Z-5 to Z-150

Z-250 to Z-1000

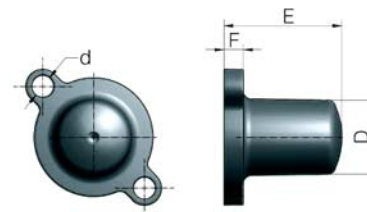

incl. screws  
Material: Z-5 to Z-150: PA6 GF15, up to 120°C, briefly 180°C  
Material: Z-250 to Z-1000: POM, up to 100°C, briefly 140°C

Suitable for screw jacks Z, GSZ, MSZ (MSZ up to size 50) and bevel gearboxes KSZ, KGZ

Part no.	D	d	E	F	Screws DIN 912	kg
Z-5-SK	25	7	32	8	M6x16	0.02
Z-10-SK	30	9	32	8	M8x16	0.04
Z-25-SK	31	9	49	8	M8x16	0.05
Z-35-SK	35	11	54	8	M10x20	0.07
Z-50-SK	35	11	55	8	M10x20	0.08
Z-100/150-SK	46	13.5	74	8	M12x25	0.12
Z-250-SK	60	17.5	82	25	M16x30	0.70
Z-350-SK	75	20	85	30	M18x30	0.90
Z-500-SK	90	22	125	35	M20x40	1.20
Z-750-SK	110	22	122	28	M20x40	1.50
Z-1000-SK	100	26	142	30	M24x40	2.20

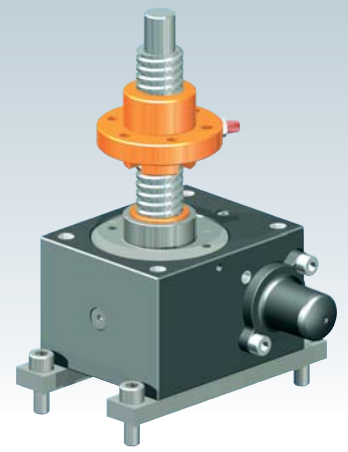

## For the S and R version



## Fixing strips BFL

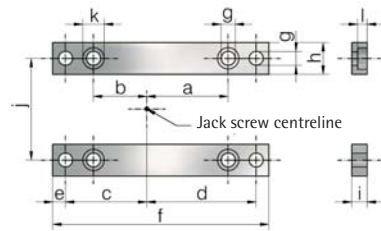

Part no.	a	b	c	d	e	f	g	h	i	j	k	l	kg
GSZ-2-BFL	32	16	29.5	45.5	7.5	90	6.6	14	10	38	11	6.4	0.16
GSZ-5-BFL	39	21	41	59	10	120	9	20	10	52	14	6	0.32
GSZ-10-BFL	49	29	50	70	10	140	9	20	14	63	14	6	0.50
GSZ-25-BFL	64	42	64	86	10	170	11	25	12	81	17	7.5	0.75
GSZ-50-BFL	87	63	90	114	13	230	13	30	20	115	19	7	2.00
GSZ-100-BFL	100	66	101	135	17	270	18	40	25	131	26	11	3.70

Identical to the previous MSZ types

Material: Steel, corrosion-resistant / GSZ-2-BFL: Stainless steel  
Incl. screws



## Pivot bearing plate KAR

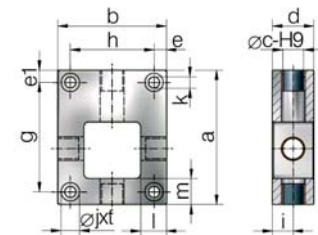

Part no.	a	b	c	d	e	e1	g	h	i	j	k	l	m	t	kg
GSZ-2-KAR <sup>1)</sup>	70	50	16	30	6	6	48	38	13	13	6.6	11	13	8	0.16
GSZ-5-KAR	80	72 <sup>2)</sup>	16	30	10	10	60	52	15	15	9	18	10	9	0.80
GSZ-10-KAR	100	85 <sup>2)</sup>	16	30	11	11	78	63	15	15	9	16	11	9	1.15
GSZ-25-KAR	130	105 <sup>2)</sup>	20	40	12	12	106	81	20	18	11	25	25	11	2.80
GSZ-50-KAR	180	145	30	50	15	15	150	115	25	20	13	24	30	13	5.30
GSZ-100-KAR	200	175	40	70	22	17	166	131	35	26	17	40	30	18	11.1

Identical to the previous MSZ types

Material: Steel, corrosion-resistant / GSZ-2-KAR: Aluminium, corrosion-resistant  
Incl. screws

<sup>1)</sup>Pivot mounts GSZ-2-LB available (Z-5/10-LB with shorter journals)

<sup>2)</sup>CAUTION: 2 mm narrower than Z-...-KAR



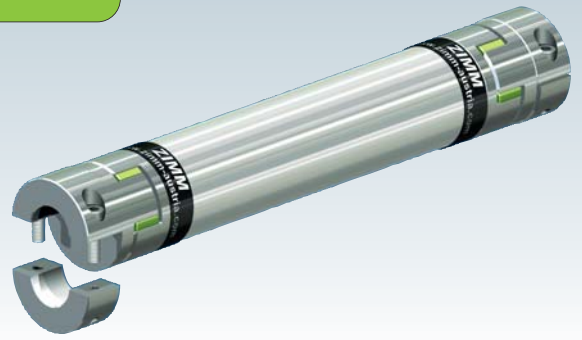

## Connecting shaft VWZ

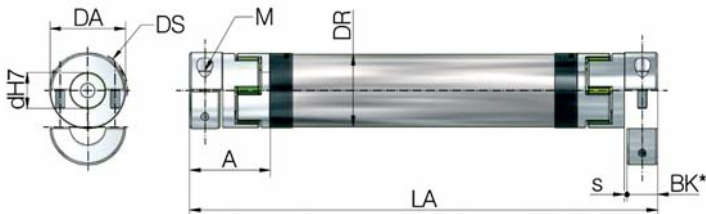

### Standard bores "d" [mm]

VWZ-30	8, 9, 10, 11, 12, 14, 15, 16
VWZ-40	9, 10, 11, 12, 14, 15, 16, 18, 19, 20, 22
VWZ-60	10, 11, 12, 14, 15, 16, 18, 19, 20, 22, 24, 25, 28, 30, 32
VWZ-60V	12, 15, 16, 18, 20, 22, 24, 25, 28, 30, 32, 35
VWZ-80	16, 19, 20, 22, 24, 25, 28, 30, 32, 35, 38, 40, 42, 45
VWZ-100	25, 28, 32, 38, 40, 42, 45, 48, 50, 55

## Dimensions, technical data

Size	Dimensions								Clamping screw		Moment of inertia		Torsional stiffness		Weight	
	DA [mm]	DS [mm]	DR [mm]	BK* [mm]	s [mm]	A [mm]	LA min [mm]	M 10.9	Tightening torque [Nm]	per coupling [ $10^{-3} \text{kgm}^2$ ]	tube/m [ $10^{-3} \text{kgm}^2$ ]	per star $C_{\text{dyn}}$ [Nm/rad]	per tube/m $C_{\text{dyn}}$ [Nm/rad]	both couplings [kg]	tube/m [kg]	
VWZ-30	32	32	30	15	1.5	34	99	M4	4	0.01	0.11	1375	1104	0.14	0.58	
VWZ-40	42	44.5	40	17	1.5	46	133	M5	8	0.08	0.2	3700	2332	0.36	0.76	
VWZ-60	56	57	60	30	2	63	177	M6	15	0.24	0.8	9917	8292	0.94	0.97	
VWZ-60V	67	68	60	35	2	73	205	M8	35	0.46	0.8	24417	8292	1.42	0.97	
VWZ-80	82	85	80	40	2	84	249	M10	70	2.4	3	33667	29102	2.98	2.00	
VWZ-100	102	105	100	50	2	97	283	M12	120	6	5.8	67667	58178	4.62	2.47	

\*BK = shaft extension clamping length

## Torques

Size	Elastomer star		Maximum transmittable torque by clamp hub depending on the bore diameter (clamp force)																Coupling type		
	Rated torque [Nm]	Max. torque [Nm]	Ø9 [Nm]	Ø11 [Nm]	Ø14 [Nm]	Ø16 [Nm]	Ø19 [Nm]	Ø20 [Nm]	Ø22 [Nm]	Ø24 [Nm]	Ø25 [Nm]	Ø28 [Nm]	Ø30 [Nm]	Ø32 [Nm]	Ø38 [Nm]	Ø40 [Nm]	Ø42 [Nm]	Ø45 [Nm]		Ø48 [Nm]	Ø55 [Nm]
VWZ-30	12	25	21	26	33	37	-	-	-	-	-	-	-	-	-	-	-	-	-	-	KUZ-KK-16
VWZ-40	17	34	-	41	52	60	70	74	81	-	-	-	-	-	-	-	-	-	-	-	KUZ-KK-24
VWZ-60	60	120	-	60	76	87	104	109	120	131	136	153	164	175	-	-	-	-	-	-	KUZ-KK-32
VWZ-60V	160	320	-	-	-	120	-	188	206	-	235	-	-	301	-	-	-	-	-	-	KUZ-KK-35
VWZ-80	325	650	-	-	-	325	386	406	447	488	508	568	610	650	772	-	854	915	-	-	KUZ-KK-45
VWZ-100	530	1060	-	-	-	-	-	-	-	-	570	638	-	730	866	914	960	1029	1097	1250	KUZ-KK-60

The max. torque is limited either by the star or by the clamping force

### Shafts with split shells

- Split shells permit easy radial insertion
- High concentricity
- High clamping forces
- Low moment of inertia

- Stepless adjustment facility thanks to the clamp hub rather than a fitted drive key
- Drive keyway available on request
- Material: High-tensile aluminium (stainless steel on request)

### Elastomer star

- Permanently free of play, dampens vibration
- Shore hardness 64D
- Colour: ZIMM green
- Temperature range: 0°C to +70°C reduced to -20°C, to +100°C (Mx0.55)



### Ordering example:

VWZ-60-LA 1800-20/25

Size  
Length  
Bores for couplings

n=1500 rpm (specify the speed)

### VWZ length calculation (identical for Z and GSZ)

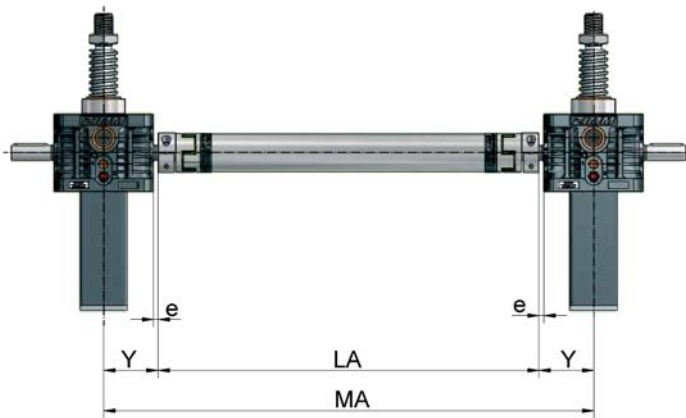

LA = External length (incl. coupling)  
MA = Distance between centres of gearboxes

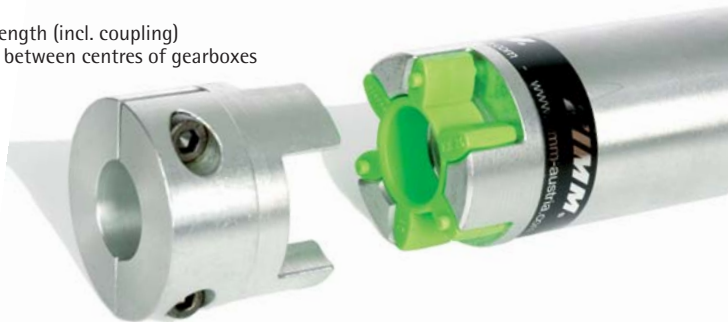

Screw jack	Connecting shaft	e	Y	A
GSZ-2	VWZ-30	6	31	34
Z-5	VWZ-30	9	45	34
Z-5	VWZ-40	7	43	46
Z-5	VWZ-60	2	38	63
Z-10	VWZ-30	12.5	55	34
Z-10	VWZ-40	10.5	53	46
Z-10	VWZ-60	2.5	45	63
Z-25	VWZ-40	28	80.5	46
Z-25	VWZ-60	15	67.5	63
Z-25	VWZ-80	5	57.5	84
Z-35	VWZ-40	28	84	46
Z-35	VWZ-60	15	71	63
Z-35	VWZ-60V*	10	66	73
Z-35	VWZ-80*	5	61	84
Z-50	VWZ-60	17.5	90	63
Z-50	VWZ-60V	12.5	85	73
Z-50	VWZ-80*	7.5	80	84
Z-100	VWZ-60	30	124	63
Z-100	VWZ-60V	25	119	73
Z-100	VWZ-80	20	114	84
Z-150	VWZ-60	30	130	63
Z-150	VWZ-60V	25	125	73
Z-150	VWZ-80	20	120	84
Z-250	VWZ-80	24	144	84
Z-250	VWZ-100	14	134	97
Z-350	VWZ-80	35	175	84
Z-350	VWZ-100	25	165	97
Z-500	VWZ-80	75	240	84
Z-500	VWZ-100	65	230	97

\*cannot be fitted with pivot mounts LB

### Maximum length - dependent on speed

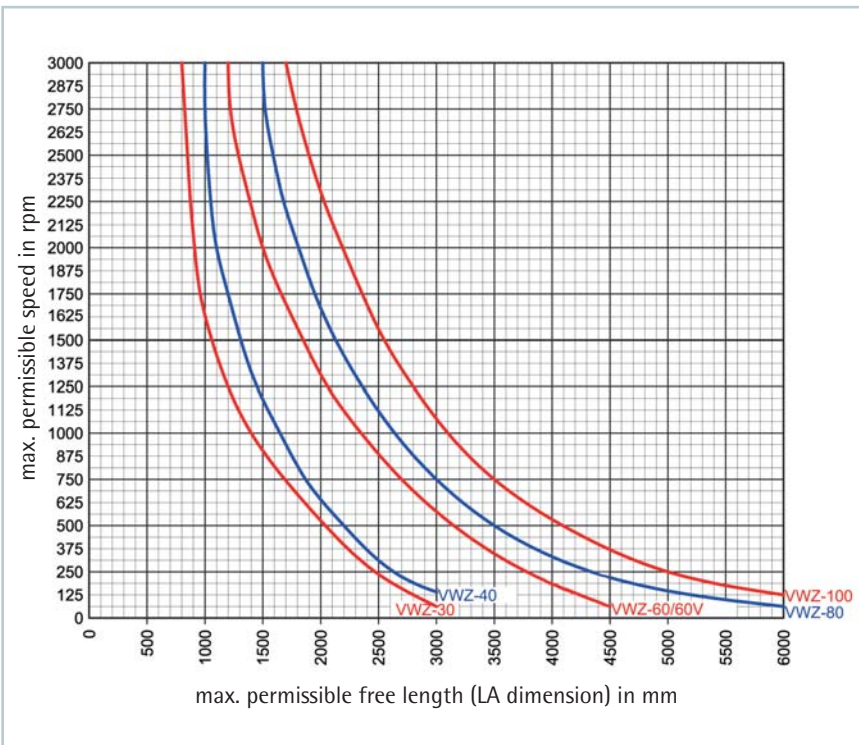

### max. permissible offset

Lateral offset:



Kr max. 1.5 mm per 100 mm LI

Angular offset:



max. 2° (1° per coupling)

Axial offset:



ca. +/- 1 bis 2 mm



## VWZ with rigid hub, for pedestal bearing use

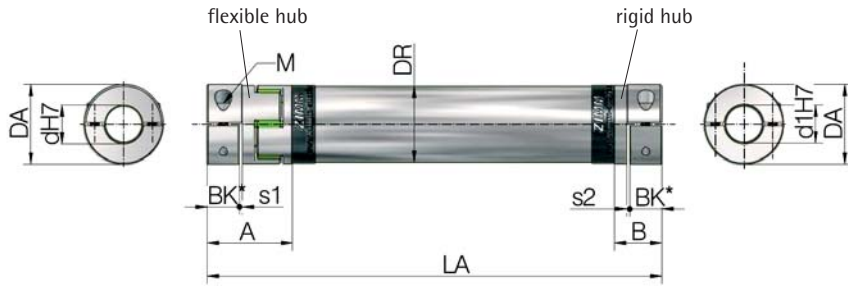

Size	A	B	s1	s2	Bk*	d1	LA min
VWZ-30	34	20	2	1.2	15	15	85
VWZ-40	46	25	2	1.6	17	20	112
VWZ-60	63	40	2	2	30	20	154
VWZ-60V	73	42	2	2	35	30	175
VWZ-80	84	55	2	2	40	30	220
VWZ-100	97	65	2	2	50	50	251

\*BK=shaft extension clamping length

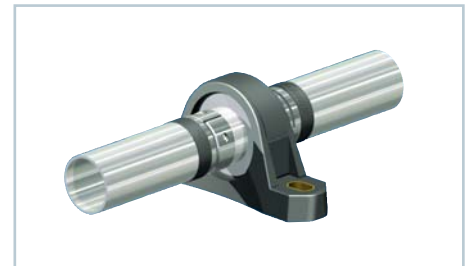

### Pedestal bearing: YES/NO?

The installation situation is very important when selecting shaft dimensions. For example, the cost of a larger diameter connecting shaft not requiring additional pedestal bearing support can be considerably less than the cost of a smaller connecting shaft requiring costly sub-structures for the additional pedestal bearing.

For this version we use the rigid hub version so that no radial misalignment can occur in the pedestal bearing.

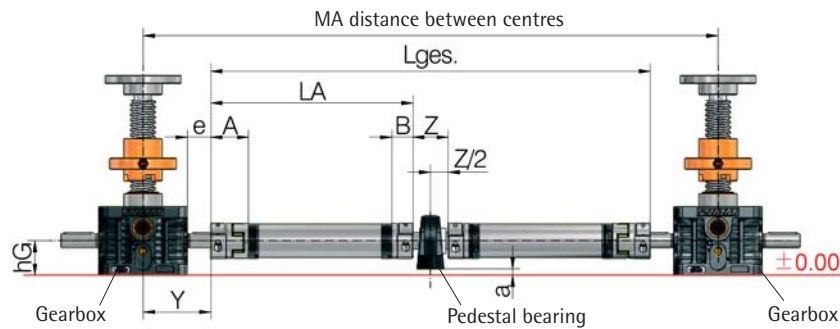

Gearbox	Connecting shaft	e	Y	A	B	Z	L <sub>wz</sub>	d1	hG	hL	a
Z-5	VWZ-30	9	45	34	20	44	74	15	31	30.2	0.8
Z-5	VWZ-40	7	43	46	25	42	76	20	31	33.3	-2.3
Z-5	VWZ-60	2	38	63	40	42	102	20	31	33.3	-2.3
Z-10	VWZ-30	12.5	55	34	20	44	74	15	37	30.2	6.8
Z-10	VWZ-40	10.5	53	46	25	42	76	20	37	33.2	3.8
Z-10	VWZ-60	2.5	45	63	40	42	102	20	37	33.2	3.8
Z-25	VWZ-40	28	80.5	46	25	42	76	20	41	33.2	7.8
Z-25	VWZ-60	15	67.5	63	40	42	102	20	41	33.2	7.8
Z-25	VWZ-80	5	57.5	84	55	50	130	30	41	42.9	-1.9
Z-35	VWZ-40	28	84	46	25	42	76	20	50	33.2	16.8
Z-35	VWZ-60	15	71	63	40	42	102	20	50	33.2	16.8
Z-35	VWZ-60V*	10	66	73	42	60	130	30	50	42.9	7.1
Z-35	VWZ-80*	5	61	84	55	50	130	30	50	42.9	7.1
Z-50	VWZ-60	17.5	90	63	40	42	102	20	58	33.3	24.7
Z-50	VWZ-60V	12.5	85	73	42	60	130	30	58	42.9	15.1
Z-50	VWZ-80*	7.5	80	84	55	50	130	30	58	42.9	15.1
Z-100	VWZ-60	30	124	63	40	42	102	20	80	33.2	46.8
Z-100	VWZ-60V	25	119	73	42	60	130	30	80	42.9	37.1
Z-100	VWZ-80	20	114	84	55	50	130	30	80	42.9	37.1
Z-150	VWZ-60	30	130	63	40	42	102	20	92.5	33.2	59.3
Z-150	VWZ-60V	25	125	73	42	60	130	30	92.5	42.9	49.6
Z-150	VWZ-80	20	120	84	55	50	130	30	92.5	42.9	49.6
Z-250	VWZ-80	24	144	84	55	50	130	30	105	42.9	62.1
Z-250	VWZ-100	14	134	97	65	70	170	50	102	57.2	44.8
Z-350	VWZ-80	35	175	84	55	50	130	30	115	42.9	72.1
Z-350	VWZ-100	25	165	97	65	70	170	50	115	57.2	57.8
Z-500	VWZ-80	75	240	84	55	50	130	30	130	42.9	87.1
Z-500	VWZ-100	65	230	97	65	70	170	50	130	57.2	72.8

\*cannot be fitted with pivot mounts LB



Ordering example:

VWZ-60-LA1800-25/20S

Size

Length

Bore 1st side

Bore 2nd side (S = rigid hub)

n=1500 rpm (specify the speed)



## Pedestal bearing, shaft extension

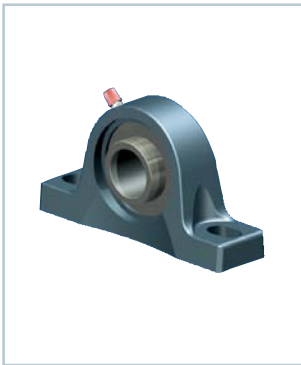

**Pedestal bearing STL**  
for connecting shaft VWZ

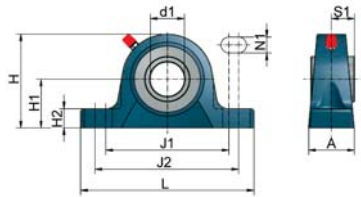

Part no.	d1	A	H	H1	H2	J1	J2	L	N1	S1	kg
STL-15-G	15	32	56	30.2	14	88	106	127	11.5	15.3	0.47
STL-20-G	20	32	65	33.3	14	88	106	127	11.5	18.3	0.59
STL-30-G	30	40	82.5	42.9	17	108	127	152	14	22.2	1.10
STL-40-G	40	48	99	49.2	19	125	146	175	14	30.2	1.85
STL-50-G	50	54	114.5	57.2	22	149	165	203	18	32.6	2.70

We use high-quality pedestal bearings.  
Housing material: Grey cast iron, primed in blue  
Bearing material: Roller bearing steel  
Temperature range: -30°C to +120°C



Pedestal bearings of plastic "black" or "white" (foodstuffs applications) on request.  
**CAUTION:** Dimensions may change!

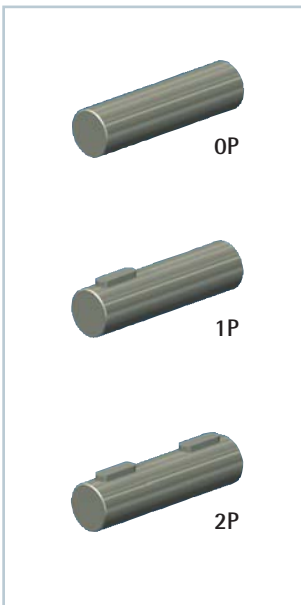
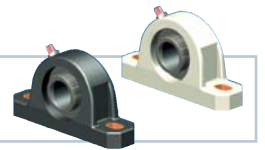

**Shaft extension**

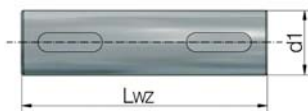

Material: Steel, ground

Part no.	d1	Lwz	kg
WZ-15/74-?P	15	74	0.10
WZ-20/76-?P	20	76	0.19
WZ-20/102-?P	20	102	0.25
WZ-30/130-?P	30	130	0.72
WZ-40/170-?P	40	170	1.67
WZ-50/170-?P	50	170	2.61

### Examples:

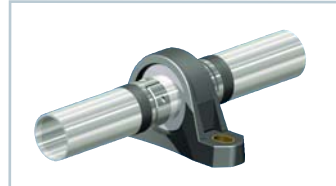

VWZ with rigid hub, for pedestal bearings



Pedestal bearing with handwheel for driving the VWZ shaft

Shaft extension without fitted key (OP)

Shaft extensions with fitted key at one end (1P)



ZIMM VWZ shafts of 500 mm length and more are checked for concentricity as standard!



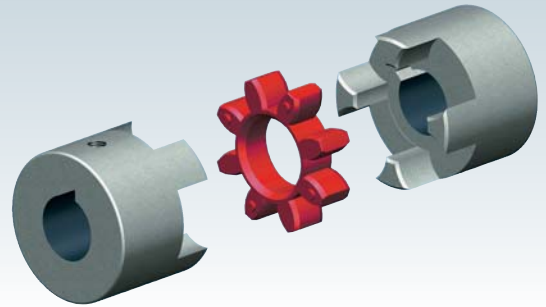

## Standard coupling KUZ

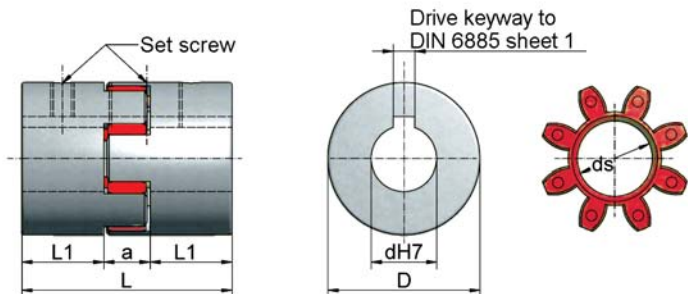

### Standard bores "d" [mm]

KUZ-09	U, 5*, 6, 7, 8, 9
KUZ-14	U, 9, 11, 14
KUZ-19	U, 11, 14, 16, 19
KUZ-24	U, 11, 14, 16, 19, 19L, 20, 24
KUZ-28	U, 14, 16, 19, 20, 24, 25, 28
KUZ-38	U, 25, 28, 28L, 32, 38
KUZ-45	U, 25, 28, 32, 38, 42, 45
KUZ-55	U, 28, 42, 48, 55

Other diameters available on request  
 U = not drilled (KUZ-14 and KUZ-19 pre-drilled Ø6.3)

L = long hub

\*Coupling with set screw, without keyway

### Dimensions

Size	D	L	L1	a	ds <sub>star</sub>	L1 <sub>long hub</sub>	Set screw	Tightening torque [Nm]
KUZ-09	20	30	10	10	-	-	M4	1.5
KUZ-14	27.5	44	16	12	-	-	M6 (M4)	4.8 (1.5)
KUZ-19	34.5	51	19	13	12	-	M6	4.8
KUZ-24	40	66	25	16	17	40	M5	2
KUZ-28	55	78	30	18	26	-	M5	2
KUZ-38	65	90	35	20	29	60	M6	4.8
KUZ-45	80	114	45	24	37	-	M8	10
KUZ-55	95	126	50	26	45	-	M8	10
KUZ-60	105	140	56	28	50	-	M8	10
KUZ-70	120	160	65	30	59	-	M10	17
KUZ-75	135	185	75	35	67	-	M10	17
KUZ-90	160	210	85	40	79	-	M10	17

### Coupling with keyway and set screw

- standard coupling with keyway and set screw
- provides rotational resilience
- maintenance-free
- material: as shown in the table

### Elastomer star

- material: Polyurethane
- medium to good damping
- very good long-term strength
- temperature range: -20°C to +70°C reduced to -30°C, up to +100°C (Mx0.55)

### Technical data

Size	Rated torque [Nm]	max. Torque [Nm]	max. speed [rpm]	Shore hardness Star	Material*	Weight, drilled [kg]	Torsional stiffness C <sub>dyn</sub> [Nm/rad]	Moment of inertia [10 <sup>-3</sup> kgm <sup>2</sup> ]
KUZ-09	3	6	28000	92A	A	0.05	-	-
KUZ-14	4.5	4.5	20000	55D	S	0.14	254	0.02
KUZ-19	7.3	7.3	14000	55D	S	0.27	274	0.03
KUZ-24	17	34	14000	98A	S	0.34	2920	0.1
KUZ-28	60	120	10600	98A	S	0.9	9930	0.4
KUZ-38	160	320	8500	98A	S	1.5	26770	1.4
KUZ-45	325	650	7100	98A	G	2.35	48570	2.5
KUZ-55	450	900	6000	98A	G	3.55	54500	6.1
KUZ-60	525	1050	5600	98A	G	4.85	65290	10.2
KUZ-70	625	1250	4750	98A	G	7.4	94970	20.3
KUZ-75	900	1300	4250	98A	G	10.8	129510	37.1
KUZ-90	1500	3000	3550	98A	G	17.7	197500	84

\*A = Aluminium, S = Sintered steel, G = Cast iron



### Ordering example:

KUZ-24-20/24

Size

Bore d end 1

Bore d end 2

### Potential assembly errors

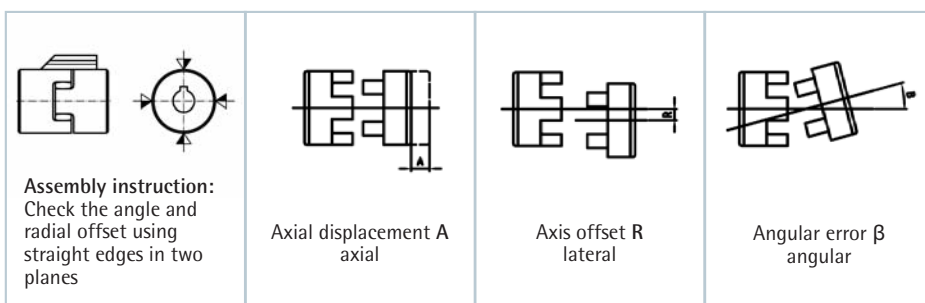

### Permissible assembly errors

Size	A	R	β
KUZ-09	0.8	0.15	1.0°
KUZ-14	0.75	0.4	0.5°
KUZ-19	0.75	0.4	0.5°
KUZ-24	1.2	0.2	0.9°
KUZ-28	1.4	0.22	0.9°
KUZ-38	1.5	0.25	0.9°
KUZ-45	1.8	0.28	1.0°
KUZ-55	2	0.32	1.0°
KUZ-60	2.1	0.36	1.1°
KUZ-70	2.2	0.38	1.1°
KUZ-75	2.6	0.42	1.2°
KUZ-90	3	0.48	1.2°

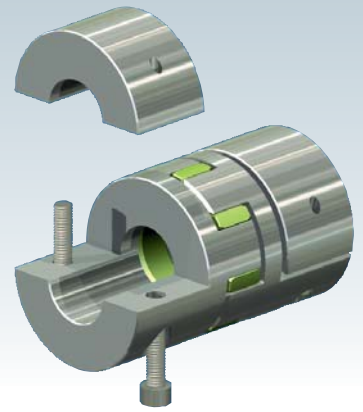

## Clamp coupling KUZ-KK

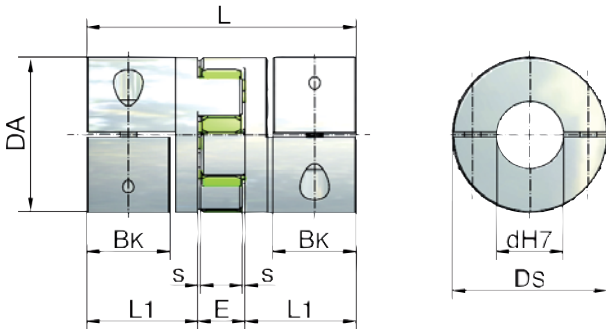

\*BK=shaft extension clamping length

### Coupling with split shells

- Split shells permit easy radial insertion
- High concentricity
- High clamping forces
- Low moment of inertia
- Stepless adjustment facility thanks to the clamp hub rather than a fitted drive key
- Keyway available on request
- Material: high-tensile aluminium

### Standard bores "d" [mm]

KUZ-KK-16	8, 9, 10, 11, 12, 14, 15, 16
KUZ-KK-24	9, 10, 11, 12, 14, 15, 16, 18, 19, 20, 22
KUZ-KK-32	10, 11, 12, 14, 15, 16, 18, 19, 20, 22, 24, 25, 28, 30, 32
KUZ-KK-35	12, 15, 16, 18, 20, 22, 24, 25, 28, 30, 32, 35
KUZ-KK-45	16, 19, 20, 22, 24, 25, 28, 30, 32, 35, 38, 40, 42, 45
KUZ-KK-60	25, 28, 32, 38, 40, 42, 45, 48, 50, 55

### Elastomer star

- Permanently free of play, dampens vibration
- Shore hardness 64D
- Colour: ZIMM green
- Temperature range: 0°C to +70°C reduced to -20°C, to +100°C (Mx0.55)

## Dimensions, technical data

Coupling size	Dimensions							Clamping screw M	Tightening torque [Nm]	Moment of inertia [10 <sup>-3</sup> kgm <sup>2</sup> ]	Torsional stiffness C <sub>tdyn</sub> [Nm/rad]	Weight [kg]
	DA [mm]	DS [mm]	L [mm]	L1 [mm]	BK* [mm]	s [mm]	E [mm]					
KUZ-KK-16	32	32	54	21	15	1.5	12	M4	4	0.01	1375	0.10
KUZ-KK-24	42	44.5	66	25	17	1.5	16	M5	8	0.08	3700	0.20
KUZ-KK-32	56	57	98	40	30	2	18	M6	15	0.24	9917	0.55
KUZ-KK-35	67	68	114	47	35	2	20	M8	35	0.51	24417	0.90
KUZ-KK-45	82	85	134	55	40	2	24	M10	70	2.4	33667	1.60
KUZ-KK-60	102	105	156	65	50	2	26	M12	120	6	67667	2.70



### Ordering example:

KUZ-KK-32-20/24

Size

Bore d end 1

Bore d end 2

## Torques

Coupling size	Elastomer star		Maximum transmittable torque of clamp hub depending on the bore diameter (clamp force)																	
	Rated torque [Nm]	Max. torque [Nm]	Ø9 [Nm]	Ø11 [Nm]	Ø14 [Nm]	Ø16 [Nm]	Ø19 [Nm]	Ø20 [Nm]	Ø22 [Nm]	Ø24 [Nm]	Ø25 [Nm]	Ø28 [Nm]	Ø30 [Nm]	Ø32 [Nm]	Ø38 [Nm]	Ø40 [Nm]	Ø42 [Nm]	Ø45 [Nm]	Ø48 [Nm]	Ø55 [Nm]
KUZ-KK-16	12	25	21	26	33	37	-	-	-	-	-	-	-	-	-	-	-	-	-	-
KUZ-KK-24	17	34	-	41	52	60	70	74	81	-	-	-	-	-	-	-	-	-	-	-
KUZ-KK-32	60	120	-	60	76	87	104	109	120	131	136	153	164	175	-	-	-	-	-	-
KUZ-KK-35	160	320	-	-	-	120	-	188	206	-	235	-	-	301	-	-	-	-	-	-
KUZ-KK-45	325	650	-	-	-	325	386	406	447	488	508	568	610	650	772	-	854	915	-	-
KUZ-KK-60	530	1060	-	-	-	-	-	-	-	-	570	638	-	730	866	914	960	1029	1097	1250

1. Axial offset - axial

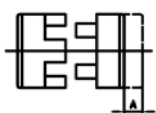

2. Axial offset - lateral

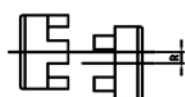

3. Angular error - angular



Size	max. axial offset in mm (axial)	max. axial offset in mm (lateral)	max. angular error in degrees (angular)
KUZ-KK-16	±1	0.08	1°
KUZ-KK-24	±2	0.08	1°
KUZ-KK-32	±2	0.10	1°
KUZ-KK-35	±2	0.15	1°
KUZ-KK-45	±2	0.12	1°
KUZ-KK-60	±2	0.14	1°



Motor flange GSZ-2

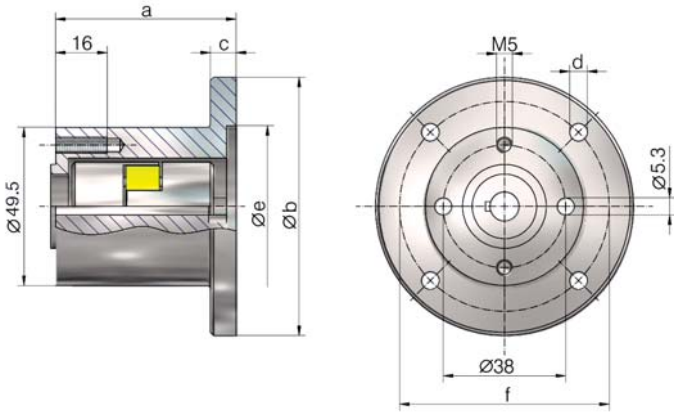

Material: Hard anodised aluminium  
Incl. screws\*\*

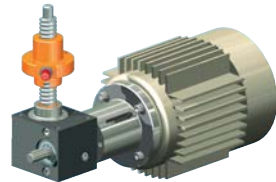
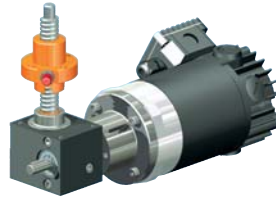
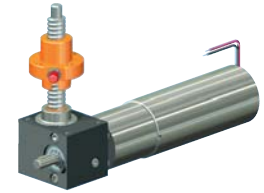

Motor flange Part no.	Motor type	Coupling part no.		2 of screws gearbox side DIN 912 (according to fitting)**	4 of screws motor side DIN 912 incl. spring washers	a	Øb	c	Ød	Øe	Øf	kg
		Size	Bore Ø Gearbox Motor									
GSZ-2-MF-49-51*	Ø53	KUZ-09	- 9 / 6	M5x55, M5x70	M4x30	51	49	-	4.3	25	36	0.19
GSZ-2-MF-80-51	56 B14C	KUZ-09	- 9 / 9	M5x55, M5x70	M5x20	51	80	9	5.5	50	65	0.22
GSZ-2-MF-80-41+P-120-15	63 B14B	KUZ-14	- 9 / 11	M5x55, M5x70, M5x45	M6x25	56	120	15	6.6	80	100	0.55
GSZ-2-MF-80-51+P-105-15	71 B14C	KUZ-14	- 9 / 14	M5x55, M5x70	M6x20	66	105	15	6.6	70	85	0.45

\*GSZ-2-MF-49-51 is suitable only for GSZ-2 screw jacks, bevel gearboxes available for KSZ-2 on request  
\*\*Screws are included for all the various fitting options

Fitting options

(Motor flanges are suitable for screw jacks and for bevel gearboxes)

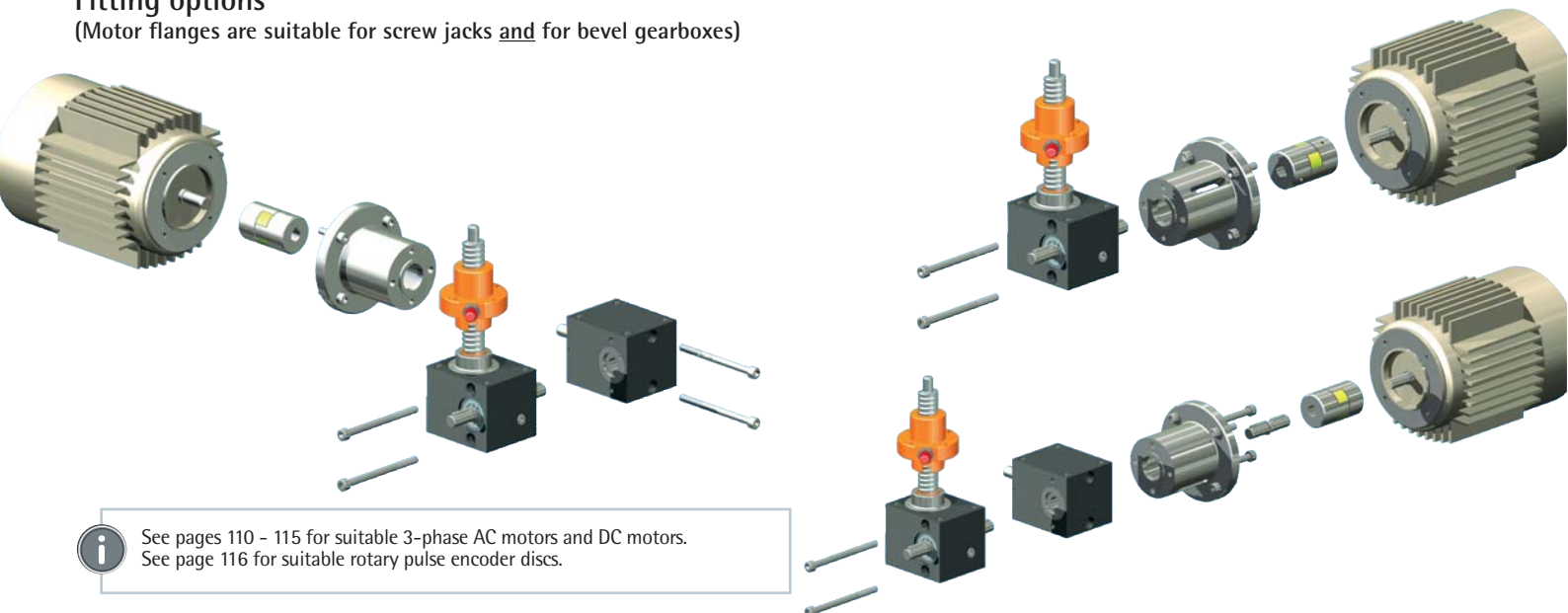

See pages 110 - 115 for suitable 3-phase AC motors and DC motors.  
See page 116 for suitable rotary pulse encoder discs.



## Motor flange Z-5 to Z-25

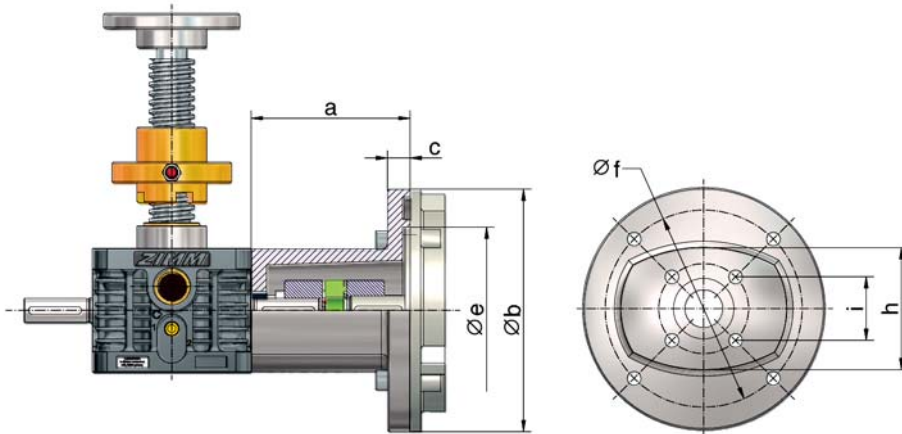

Material: Aluminium  
Incl. screws

Motor flange Part no.	Motor type	Coupling part no.		4 of screws gearbox side 8.8	4 of socket head cap screws 8.8 DIN 912 for motor	a	b	c	e	f	h	i	kg
		Size	Bore Ø										
Z-5-MF-120-60	63 B14B	KUZ-14	- 11 / 11	M6x12 - DIN 7991	M6x20 + spring washers	60	120	10	80	100	61	32.5	0.33
Z-5-MF-105-68	71 B14C	KUZ-19	- 11 / 14	M6x12 - DIN 7991	M6x20 + spring washers	68	105	10	70	85	61	32.5	0.31
Z-10-MF-120-66	63 B14B	KUZ-19	- 14 / 11	M8x16 - DIN 7991	M6x20 + spring washers	66	120	10	80	100	73	35.4	0.42
Z-10-MF-160-75	71 B5	KUZ-19	- 14 / 14	M8x16 - DIN 7991	M8x35 + nuts	75	160	15	110	130	73	35.4	0.81
Z-10-MF-160-90	80 B14B	KUZ-24	- 14 / 19	M8x16 - DIN 7991	M8x30 + spring washers	90	160	15	110	130	73	35.4	0.88
Z-25-MF-160-105	71 B5	KUZ-28	- 16 / 14	M8x20 - DIN 7991	M8x35 + nuts	105	160	15	110	130	81	42	1.11
Z-25-MF-160-105	80 B14B	KUZ-24	- 16 / 19	M8x20 - DIN 7991	M8x30 + spring washers	105	160	15	110	130	81	42	1.11
Z-25-MF-160-105	90 B14B	KUZ-24	- 16 / 24	M8x20 - DIN 7991	M8x30 + spring washers	105	160	15	110	130	81	42	1.11
Z-25-MF-160-122	100 B14C	KUZ-28	- 16 / 28	M8x20 - DIN 7991	M8x30 + spring washers	122	160	15	110	130	81	42	1.25

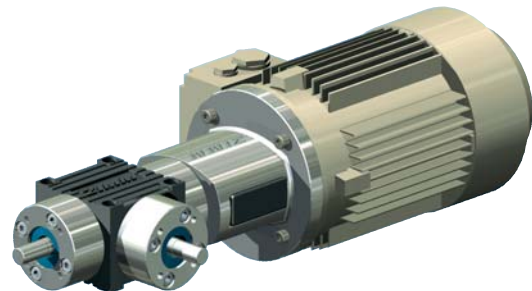
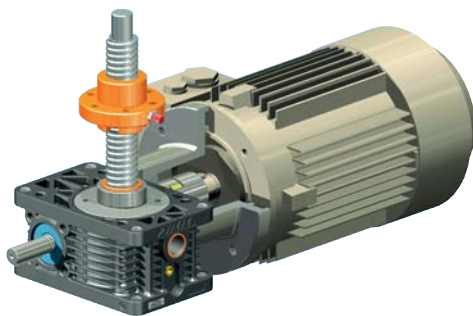

**i** Motor flange for Z-5 to Z-50 are also suitable for bevel gearboxes KSZ and KGZ.

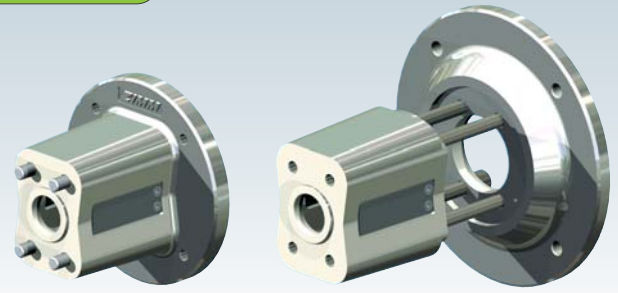

## Motor flange for Z-35 to Z-150

### Motor flange (one-piece)

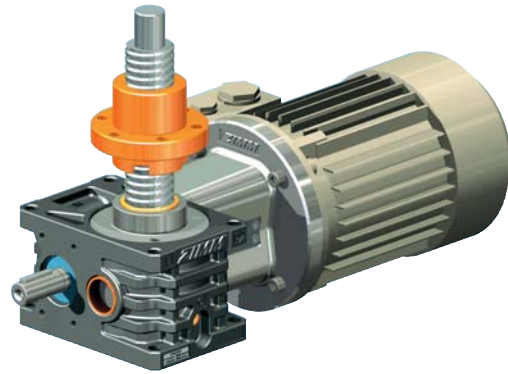
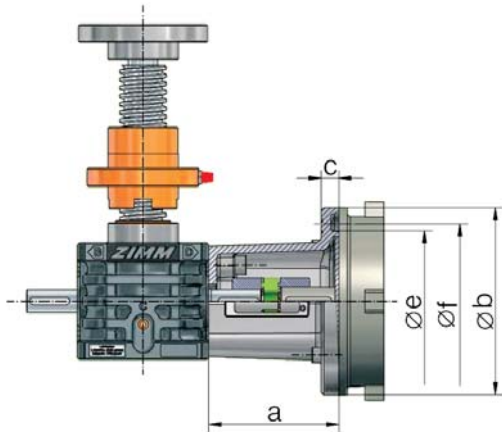

### Motor flange base + motor flange plate

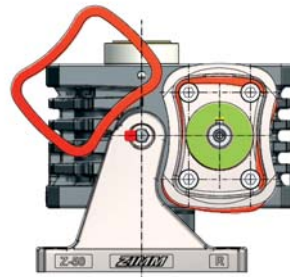
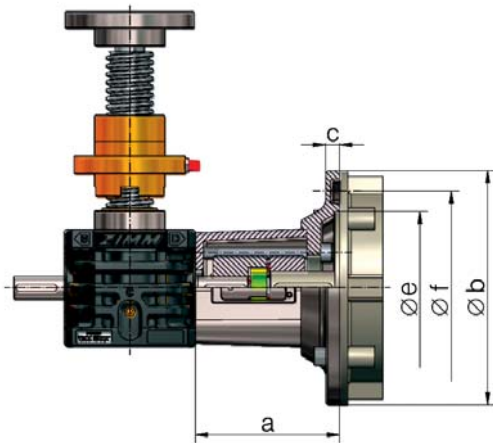

Material: GGG-50, corrosion-resistant  
Incl. screws

Motor flange Part no.	Motor type	Coupling part no.		4 of screws gearbox side DIN 912	4 of screws motor side DIN 912	a	b	c	e	f	kg
		Size	Bore Ø Gearbox Motor								
Z-35-MF-160-111	80 B14B	KUZ-24	- 19 / 19	M10x30	M8x25 <sup>1)</sup>	111	160	15	110	130	2.6
Z-35-MF-160-111	90 B14B	KUZ-24	- 19 / 24	M10x30	M8x25 <sup>1)</sup>	111	160	15	110	130	2.6
Z-35-MF-B + Z-35-MF-P-200	100 B14B	KUZ-28	- 19 / 28	M10x120	M10x30 <sup>1)</sup>	123	200	12	130	165	3.6
Z-35-MF-B + Z-35-MF-P-200	112 B14B	KUZ-28	- 19 / 28	M10x120	M10x30 <sup>1)</sup>	123	200	12	130	165	3.6
Z-35-MF-B + special plate	servomotors, geared motors, Nema motors,...										
Z-50-MF-200-116	90 B5	KUZ-28	- 20 / 24	M10x30	M10x45 <sup>2)</sup>	116	200	20	130	165	4.1
Z-50-MF-200-126	100 B14B	KUZ-28	- 20 / 28	M10x30	M10x35 <sup>1)</sup>	126	200	20	130	165	4.3
Z-50-MF-200-126	112 B14B	KUZ-28	- 20 / 28	M10x30	M10x35 <sup>1)</sup>	126	200	20	130	165	4.3
Z-50-MF-B + special plate	servomotors, geared motors, Nema motors,...										
Z-100/150-MF-200-138	100 B14B	KUZ-28	- 25 / 28	M12x40 <sup>4)</sup>	M10x35 <sup>1)</sup>	138 <sup>3)</sup>	200	20	130	165	5.2
Z-100/150-MF-200-138	112 B14B	KUZ-28	- 25 / 28	M12x40 <sup>4)</sup>	M10x35 <sup>1)</sup>	138 <sup>3)</sup>	200	20	130	165	5.2
Z-100/150-MF-B + P-200	132 B14C	KUZ-38	- 25 / 38	M12x150 <sup>4)</sup>	M10x65 <sup>1)</sup>	161 <sup>3)</sup>	200	48	130	165	8.7
Z-100/150-MF-B + special plate	servomotors, geared motors, Nema motors,...										

<sup>1)</sup> incl. spring washers

<sup>2)</sup> incl. nuts

<sup>3)</sup> for GSZ: +6 mm (plate)

<sup>4)</sup> for GSZ: M12x45/M12x160

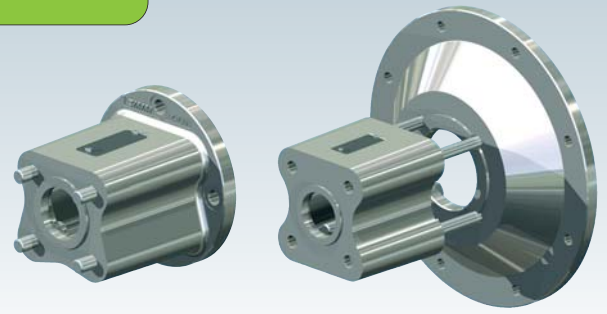

## Motor flange Z-250 to Z-1000

### Motor flange (one-piece)

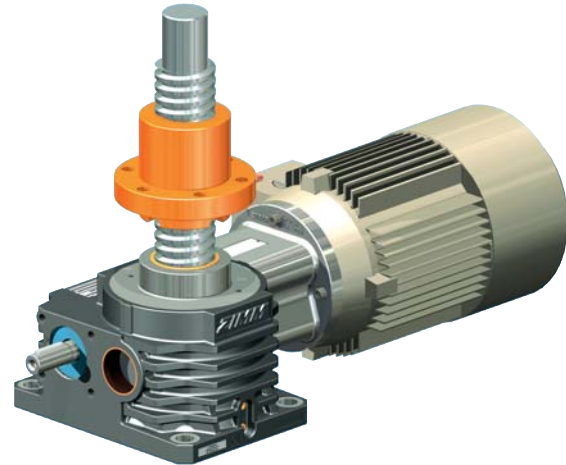
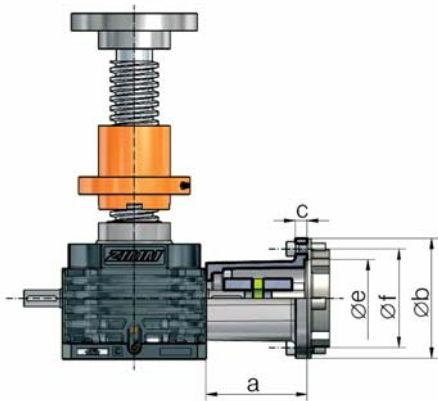

### Motor flange base + motor flange plate

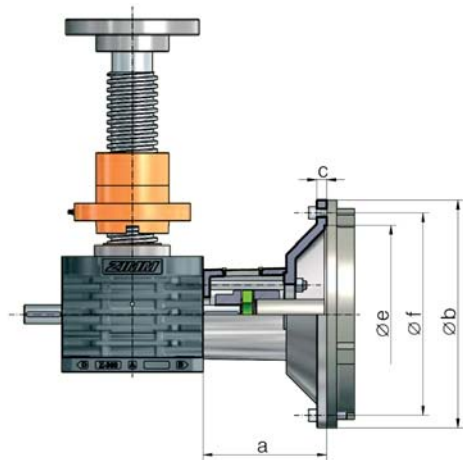

Material: GGG-50, corrosion-resistant  
Incl. screws

Motor flange Part no.	Motor type	Coupling part no. Size	Bore Ø Gearbox Motor	4 of screws gearbox side DIN 912	4 of screws motor side DIN 912	a	b	c	e	f	kg
Z-250-MF-200-168	100 B14B	KUZ-38	- 28L / 28L	M16x55	M10x40 <sup>1)</sup>	168	200	20	130	165	8.5
Z-250-MF-200-168	112 B14B	KUZ-38	- 28L / 28L	M16x55	M10x40 <sup>1)</sup>	168	200	20	130	165	8.5
Z-250-MF-200-168	132 B14C	KUZ-38	- 28 / 38	M16x55	M10x40 <sup>1)</sup>	168	200	20	130	165	8.5
Z-250-MF-200-168 + P-350	160 B5	KUZ-45	- 28 / 42	M16x55	M16x70 <sup>2)</sup>	198	350	30	250	300	20.5
Z-250-MF-200-168 + P-350	180 B5	KUZ-55	- 28 / 48	M16x55	M16x70 <sup>2)</sup>	198	350	30	250	300	20.5
Z-250-MF-200-168 + P-400	200 B5	KUZ-55	- 28 / 55	M16x55	M16x70 <sup>2)</sup>	200	400	32	300	350	25
Z-250-200-168 -MF-B + special plate	servomotors, geared motors, Nema motors,...										
Z-350-MF-B + P-350	180 B5	KUZ-55	- 38 / 48	4x M18 <sup>3)</sup>	M16x60 <sup>2)</sup>	211	350	19	250	300	24
Z-350-MF-B + P-400	200 B5	KUZ-55	- 38 / 55	4x M18 <sup>3)</sup>	M16x60 <sup>2)</sup>	211	400	19	300	350	27
Z-350-MF-B + P-450	225 B5	KUZ-60	- 38 / 60 <sup>4)</sup>	4x M18 <sup>3)</sup>	M16x60 <sup>2)</sup> (8x)	243	450	19	350	400	33
Z-350-MF-B + special plate	servomotors, geared motors, Nema motors,...										
Z-500-MF-B + P-400	200 B5	KUZ-55	- 40 / 55	5x M20 <sup>3)</sup>	M16x60 <sup>2)</sup>	251	400	19	300	350	32
Z-500-MF-B + P-450	225 B5	KUZ-60	- 40 / 60 <sup>4)</sup>	5x M20 <sup>3)</sup>	M16x60 <sup>2)</sup> (8x)	285	450	19	350	400	40
Z-500-MF-B + P-550	250 B5	KUZ-70	- 40 / 65 <sup>4)</sup>	5x M20 <sup>3)</sup>	M16x70 <sup>2)</sup> (8x)	285	550	21	450	500	55
Z-500-MF-B + special plate	servomotors, geared motors, Nema motors,...										

<sup>1)</sup> incl. spring washers

<sup>2)</sup> incl. nuts and spring washers

<sup>3)</sup> set screws 8.8 with nuts and spring washers

<sup>4)</sup> from size 225 check the shaft diameter, it can vary depending on the motor (these diameters should be suitable for 4, 6 and 8-pole motors)



Motor flange for Z-750 and Z-1000 on request

# Overview

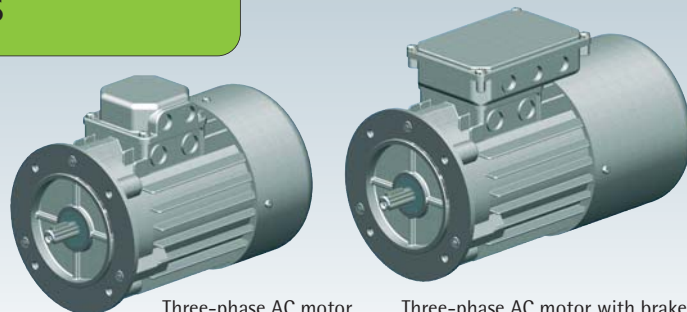

Three-phase AC motor

Three-phase AC motor with brake

## Three-phase AC motors, three-phase AC motors with brakes

Standard three-phase motors (asynchronous)  
No-load speed ~ 1500 rpm (other speeds on request)  
230/400 V  $\Delta$  50 Hz, S1 or S3-75%, ISO F  
Three-phase AC motors: IP 55  
Three-phase AC motors with brakes: IP 54

Voltage ranges

220 - 240 V  $\Delta$  50 Hz380 - 415 V  $\Delta$  50 Hz

380 - 415 V Y 50 Hz

660 - 690 V Y 50 Hz

Frame size	Power	Rated speed	Rated torque	Rated current at 400 V	for direct-on-line starting		Breakdown torque to rated torque	Moment of inertia J	Efficiency (at 100% load)	Power factor (at 100% load)	Weight without brake	Weight with brake
					Starting current to rated current	Starting torque to rated torque						
IEC	kW	rpm	Nm	A	$I_A/I_N$	$M_A/M_N$	$M_k/M_N$	approx. kgm <sup>2</sup>	$\eta$ %	cos	approx. kg	approx. kg
56	0.09	1300	0.66	0.35	2.5	1.8	2.0	0.0002	50.0	0.76	2.7	4.0
63	0.18	1330	1.30	0.65	2.3	1.9	1.9	0.0003	58.0	0.70	4.1	6.0
63	0.25*	1340	1.81	0.94	2.2	1.7	2.5	0.0004	60.0	0.76	4.2	6.5
71	0.37	1360	2.60	1.2	2.8	2.0	2.0	0.0008	63.0	0.70	6.0	8.0
71	0.75*	1370	5.33	2.1	2.9	2.1	2.4	0.0012	69.0	0.78	8.3	10.3
80	0.75	1410	5.10	2.0	4.5	2.2	2.8	0.0020	70.0	0.70	9.3	13.0
80	1.5*	1390	10.4	3.4	4.1	3.2	3.2	0.0026	72.0	0.70	11.5	15.2
90L	1.5	1410	10.3	3.7	4.9	3.0	3.0	0.0032	79.0	0.74	14.4	18.0
90L	2.2*	1400	15.2	5.2	4.5	2.7	2.7	0.0039	78.0	0.81	17.5	21.1
100L	2.2	1420	14.8	5.3	4.0	2.3	2.7	0.0046	83.0	0.74	19.2	25.5
100L	3.0	1410	20.3	6.7	3.9	2.3	2.5	0.0056	82.0	0.79	22.4	28.0
100L	4.0*	1420	27.0	8.9	4.0	2.2	2.2	0.0065	81.0	0.82	26.3	31.9
112M	4.0	1440	27.0	9.4	3.3	2.5	2.9	0.0133	83.0	0.75	30.4	38.0
112M	5.5*	1440	36.4	11.7	3.9	2.1	2.3	0.0139	84.0	0.83	33.0	40.6
132S	5.5	1440	36.0	12.0	5.8	3.0	3.0	0.0224	83.0	0.80	41.9	56.0
132M	7.5	1440	50.0	15.4	6.8	3.1	3.1	0.0293	86.0	0.82	51.0	66.0
132M	11*	1445	73.1	24.5	8.2	3.5	3.5	0.0458	83.0	0.80	74.0	89.0
160M	11	1460	72.1	20.7	7.6	2.1	2.4	0.0832	89.1	0.86	101.0	111.0
160L	15	1460	96.2	29.2	7.1	2.4	2.6	0.1506	89.4	0.83	110.0	120.0
180M	18.5	1465	119.0	34.3	7.1	2.3	2.6	0.1773	90.4	0.86	135.0	150.0
180L	22	1475	142.0	41.1	6.9	2.4	2.6	0.2936	90.9	0.85	145.0	160.0
200L	30	1475	190.0	54.0	6.6	2.1	2.3	0.6345	92.1	0.87	230.0	253.0
225S	37	1470	238.0	64.7	7.0	2.3	2.5	0.3251	92.8	0.89	338.0	361.0
225M	45	1470	286.0	77.9	7.4	2.3	2.4	0.7866	92.6	0.90	358.0	381.0
250M	55	1465	359.0	94.0	7.5	2.6	2.6	0.9483	93.4	0.90	482.0	517.0
250ML	75	1480	484.0	134.0	6.3	1.2	2.2	0.9988	94.0	0.80	535.0	570.0
280S	75	1475	476.0	136.0	6.8	2.1	2.5	1.8495	93.5	0.85	591.0	631.0
280M	90	1485	591.0	167.0	8.3	2.5	2.9	2.2306	93.6	0.85	662.0	702.0
280ML	110	1480	710.0	190.0	6.9	2.7	3.1	2.6800	94.0	0.89	750.0	790.0
315S	110	1485	709.0	199.0	7.5	2.3	2.5	2.8136	93.9	0.85	867.0	940.0
315M	132	1480	830.0	229.0	7.5	2.4	2.6	3.3435	94.7	0.88	990.0	1063.0
315M	160	1485	1040.0	277.0	7.3	2.7	2.7	3.3435	94.7	0.88	1003.0	1076.0
315M	200	1485	1277.0	349.0	7.6	2.4	2.6	3.3435	95.0	0.87	1003.0	1076.0
355M	250	1475	1619.0	432.0	7.5	2.4	2.5	5.8740	95.0	0.88	1380.0	1490.0
355M	315	1485	2024.0	542.0	6.9	2.5	2.6	6.8900	95.3	0.88	1600.0	1790.0

\*Power is higher than the IEC standard (progressive)



Sizes 63 to 132 available on short lead times  
Sizes 160 to 355 available on request

### CAUTION:

Overdimensioning the motor power risks overstressing other components. The effects must be considered not only under load but also for the no-load case.

We supply motor brakes as standard for a connection voltage of 230V AC, operating voltage 205 V DC, with bridge rectifiers.



### Ordering example:

**90-P4-1.5-B5-B-2W**

Size  
Number of poles - speed  
4-pole = 1500 rpm  
Power [kW]  
Design  
with brake (if required)  
with a second shaft end (if required)



## Three-phase AC motors, general information



### Connection arrangement

The motors usually have a terminal board with 6 terminals and a protective earth terminal in the terminal box. The stator winding can be switched into star or delta connection using the connection links.

Star/delta starting is not suitable for screw jack systems because full torque is required immediately on starting.

For motor windings 230/400V (example)

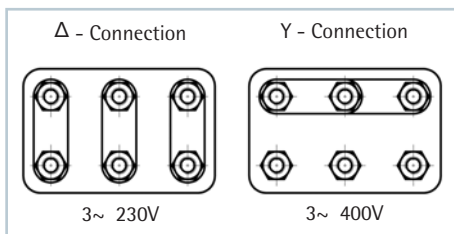

Operating voltage 230V delta:  
Motor windings 230/400V

Operating voltage 400V delta:  
Motor windings 400/660V

### Direction of rotating

Motors can be arranged for either direction of rotation. When the line phases L1, L2, L3 are connected to the motor terminals U1, V1, W1, the direction of rotation is clockwise. Swapping over two of the supply lines reverses the direction of rotation.

### Speeds

Three-phase AC motors have different rotational speeds depending on the number of poles. Generally we recommend our standard motor with 1500 rpm (4 poles).

Other numbers of poles are available on request. Pole-changing motors allow a choice of 2 different rotational speeds.

Speed (50 Hz)	Number of poles
3000	2
1500	4 (= preferred type)
1000	6
750	8
500	12

### Geared motors

Geared motors are available for particular projects on request.

### Operation with frequency converters

Especially for larger screw jacks and systems, we recommend the use of a frequency converter to achieve smooth start-up and brake ramps. This minimizes start-up noise and extends the service life of the gearbox.

When operating with a frequency converter, remember that if the motor is to be operated for extended periods at frequencies less than 25 Hz, its fan must be driven separately. This is necessary to ensure adequate motor cooling.

When operating a braked motor with a frequency converter, a separate actuation line for the brake must be provided via the frequency converter.

### Braked motor

We recommend using a braked motor to minimise the overrun time of the system. Where a screw jack is fitted with a ball screw or a double-pitch screw, a braked motor is absolutely essential. We supply motor brakes as standard for a connection voltage of 230V AC / operating voltage 205V DC, with bridge rectifiers.

Other connection voltages (24V DC, 400V AC, 500V AC) are available on request.

### Temperature monitoring

Generally we do not supply temperature monitoring because screw jack duty cycles are normally quite low or the motor is adequately dimensioned.

Temperature control thermal resistor (PTC) or bimetal (TKÖ) is available on request.

Some types are available ex stock with thermal resistor (PTC).

## Permanent-magnet DC motors



24V DC, IP 54, with terminal box

Frame size IEC	Power [P]	Speed [rpm]	Rated torque*** [Nm]	Starting torque [Nm]	Voltage [V]	Rated current [A]	Motor length (without shaft)	Weight [kg]
Ø53	60W	3000	0.17	1.4	24V DC	2.9	128	1.2
56, B14C Ø80	85W	1500**	0.53	1.5	24V DC	4.5	149*	2.7
56, B14C Ø80	165W	1500**	1.0	3.0	24V DC	8.8	196*	4.3
56, B14C Ø80	250W	1500**	1.6	4.5	24V DC	13.5	241*	5.6

\*Optional brake available (24V DC, 13W, 2 Nm, 1.1 kg), + 44 mm length

\*\* 3000 rpm motor available on request, torque remains the same

\*\*\* Short-term operation at twice the torque is possible



Other sizes available on request

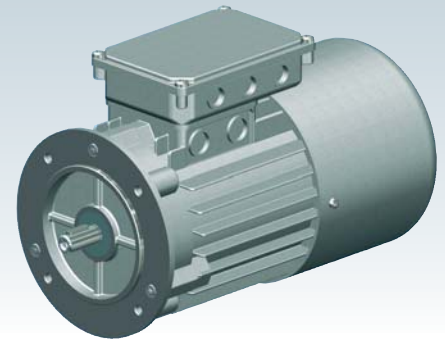

## Three-phase AC motors, three-phase AC motors with brakes, flange profile B14B, large flange

B14: Flange with internal thread  
B: Large flange

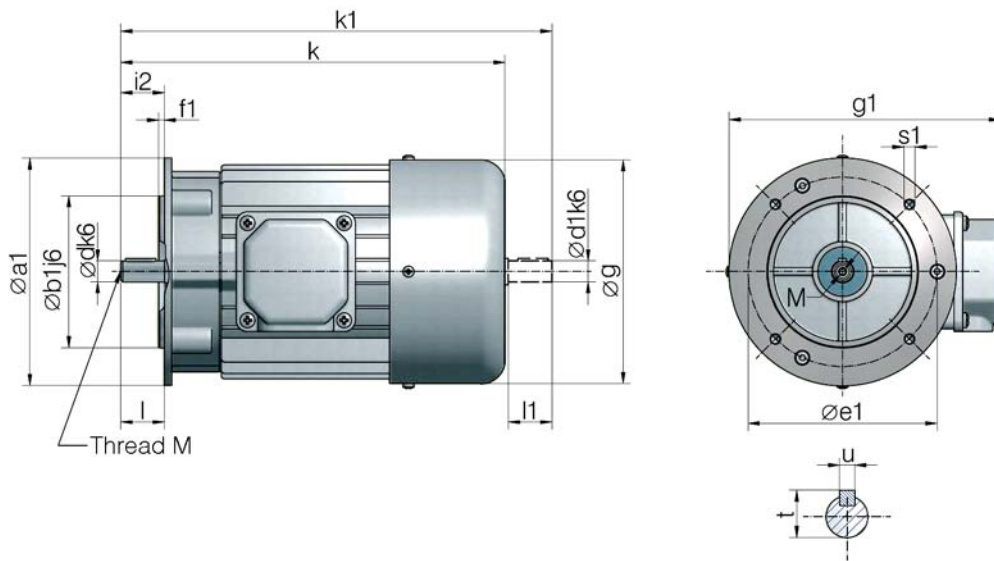

We reserve the right to change the dimensions without changing the motor designation.

Size	a1	b1	e1	f1	g	i2	s1	d	l	t	u
63	120	80	100	3.0	125	23	M6	11	23	12.5	4
71	140	95	115	3.0	141	30	M8	14	30	16.0	5
80	160	110	130	3.5	159	40	M8	19	40	21.5	6
90	160	110	130	3.5	179	50	M8	24	50	27.0	8
100	200	130	165	3.5	199	60	M10	28	60	31.0	8
112	200	130	165	3.5	223	60	M10	28	60	31.0	8

These dimensions are standardised and thus always remain the same.

Size	kW (4-pole)	without brake				with brake	with brake and second shaft end				M	
		k	k1	d1	l1	k	k	k1	d1	l1		g1
63	0.18	212	238	11	23	261	261	285	9	20	172	4
63	0.25	212	238	11	23	239	261	285	9	20	172	4
71	0.37	248	281	14	30	263	295	325	11	23	188	5
71	0.75	248	281	14	30	263	295	325	11	23	188	5
80	0.75	277	315	19	40	310	330	375	19	40	211	6
80	1.5	277	315	19	40	310	330	375	19	40	211	6
90	1.5	329	378	24	50	390	390	432	19	40	227	8
90	2.2	329	378	24	50	348	390	432	19	40	227	8
100	3.0	369	429	28	60	451	433	487	24	50	248	10
100	4.0	369	429	28	60	451	433	487	24	50	248	10
112	5.5	391	448	28	60	456	456	511	24	50	266	10

These dimensions are our standard (4-pole), but may vary in individual cases.

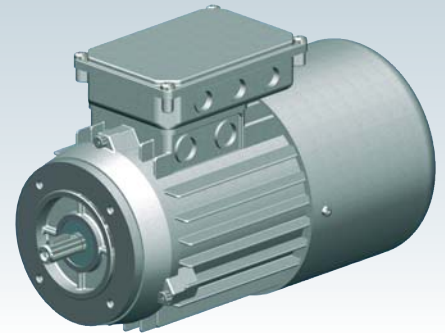

## Three-phase AC motors, three-phase AC motors with brakes, flange profile B14C, small flange

B14: Flange with internal thread  
C: Small flange

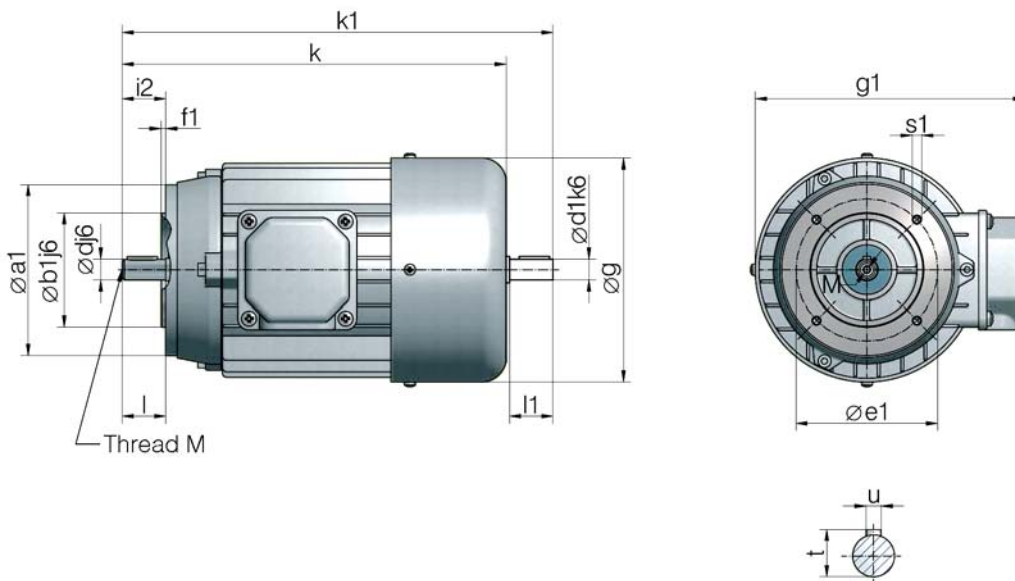

**i** We reserve the right to change the dimensions without changing the motor designation.

Size	a1	b1	e1	f1	g	i2	s1	d	l	t	u
56	80	50	65	2.5	110	20	M5	9	20	10.2	3
63	90	60	75	2.5	125	23	M5	11	23	12.5	4
71	105	70	85	2.5	141	30	M6	14	30	16.0	5
80	120	80	100	3.0	159	40	M6	19	40	21.5	6
90	140	95	115	3.0	179	50	M8	24	50	27.0	8
100	160	110	130	3.5	199	60	M8	28	60	31.0	8
112	160	110	130	3.5	223	60	M8	28	60	31.0	8
132	200	130	165	4.0	258	80	M10	38	80	41.0	10

These dimensions are standardised and thus always remain the same.

Size	kW (4-pole)	without brake				with brake	with brake and second shaft end				q1	M
		k	k1	d1	l1	k	k	k1	d1	l1		
56	0.09	189	212	9	20	243	243	-	-	-	161	4
63	0.18	212	238	11	23	261	261	285	9	20	172	4
63	0.25	212	238	11	23	239	261	285	9	20	172	4
71	0.37	248	281	14	30	263	295	325	11	23	188	5
71	0.75	248	281	14	30	263	295	325	11	23	188	5
80	0.75	277	315	19	40	310	330	375	19	40	211	6
80	1.5	277	315	19	40	310	330	375	19	40	211	6
90	1.5	329	378	24	50	390	390	432	19	40	227	8
90	2.2	329	378	24	50	348	390	432	19	40	227	8
100	3.0	369	429	28	60	451	433	487	24	50	248	10
100	4.0	369	429	28	60	451	433	487	24	50	248	10
112	5.5	391	448	28	60	456	456	511	24	50	266	10
132	7.5	490	570	38	80	585	-	-	-	-	326	12

These dimensions are our standard (4-pole), but may vary in individual cases.

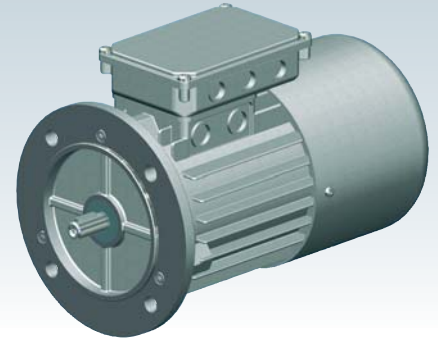

## Three-phase AC motors, three-phase AC motors with brakes, flange profile B5

B5: Flange with through holes

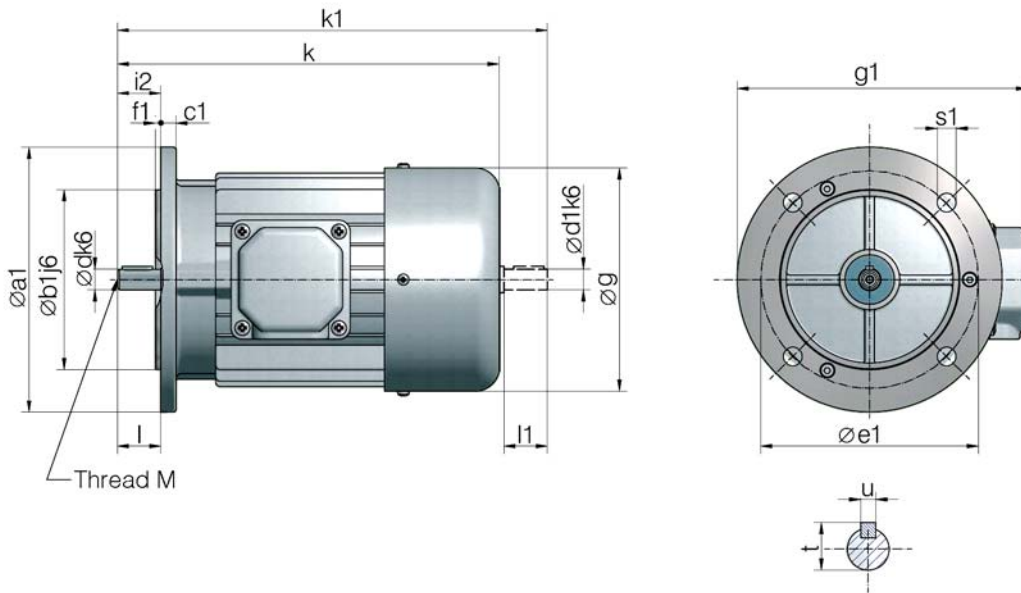

We reserve the right to change the dimensions without changing the motor designation.

Size	a1	b1	c1	e1	f1	g	i2	s1	d	l	t	u
63	140	95	5	115	3.0	125	23	9.5	11	23	12.5	4
71	160	110	7	130	3.5	141	30	9.5	14	30	16.0	5
80	200	130	8	165	3.5	159	40	11.5	19	40	21.5	6
90	200	130	8	165	3.5	179	50	11.5	24	50	27.0	8
100	250	180	10	215	4.0	199	60	14	28	60	31.0	8
112	250	180	10	215	4.0	223	60	14	28	60	31.0	8

These dimensions are standardised and thus always remain the same.

Size	kW	without brake				with brake	with brake and second shaft end					
		k	k1	d1	l1	k	k	k1	d1	l1	g1	M
63	0.18	212	238	11	23	261	261	285	9	20	172	4
63	0.25	212	238	11	23	239	261	285	9	20	172	4
71	0.37	248	281	14	30	263	295	325	11	23	188	5
71	0.75	248	281	14	30	263	295	325	11	23	188	5
80	0.75	277	315	19	40	310	330	375	19	40	211	6
80	1.5	277	315	19	40	310	330	375	19	40	211	6
90	1.5	329	378	24	50	390	390	432	19	40	227	8
90	2.2	329	378	24	50	348	390	432	19	40	227	8
100	3.0	369	429	28	60	451	433	487	24	50	248	10
100	4.0	369	429	28	60	451	433	487	24	50	248	10
112	5.5	391	448	28	60	456	456	511	24	50	266	10

These dimensions are our standard (4-pole), but may vary in individual cases.

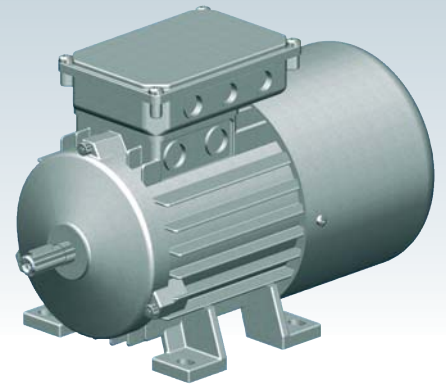

## Three-phase AC motors, three-phase AC motors with brakes, pedestal mounted type B3

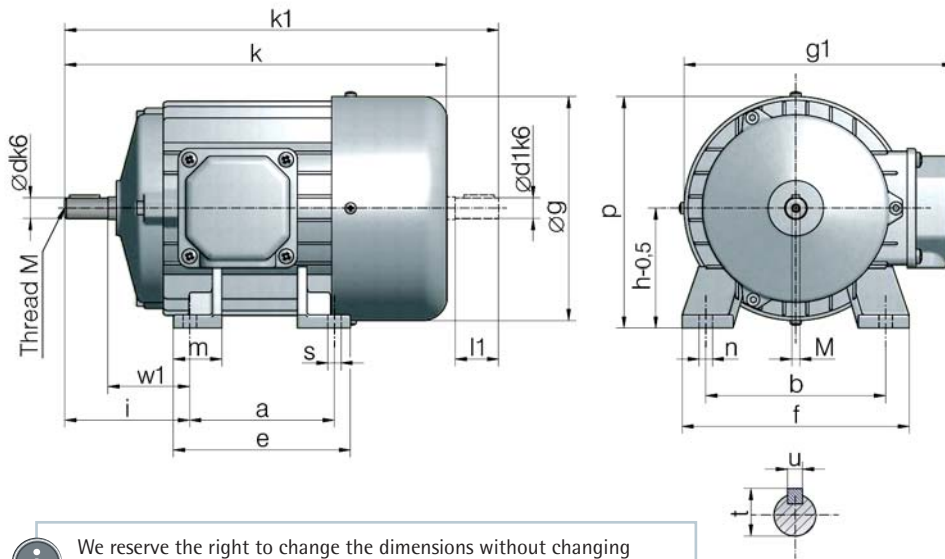

For this type, we can supply a flanged motor (e.g.: B14) with additional pedestal mounts fitted. This version is generally available on a shorter lead time. The dimensions remain the same.

Please specify the terminal box position (top, right or left when looking at the motor shaft). If not otherwise specified, we deliver up to size 112 with the box on top and from size 132 with it on the right.

**i** We reserve the right to change the dimensions without changing the motor designation.

Size	a	b	g	h	i	p*	s	n	w1	d	l	t	u
63	80	100	125	63	63	126	7	11	40	11	23	12.5	4
71	90	112	141	71	75	142	7	7	45	14	30	16.0	5
80	100	125	159	80	90	160	9	17	50	19	40	21.5	6
90	125	140	179	90	106	180	9	17	56	24	50	27.0	8
100	140	160	199	100	123	200	12	20	63	28	60	31.0	8
112	140	190	223	112	130	224	12	21	70	28	60	31.0	8
132S	140	216	262	132	169	264	12	-	89	38	80	41.0	10
132M	178	216	262	132	169	264	12	-	89	38	80	41.0	10
160M	210	254	318	160	218	320	14	-	108	42	110	45.0	12
160L	254	254	318	160	218	320	14	-	108	42	110	45.0	12
180M	241	279	358	180	231	360	14	-	121	48	110	51.5	14
180L	279	279	358	180	231	360	14	-	121	48	110	51.5	14
200L	305	318	398	200	243	400	19	-	133	55	110	59.0	16

These dimensions are standardised and thus always remain the same.

\* The height g1 is for top-mounted terminal boxes

Size	kW	without brake				with brake	with brake and second shaft end				c	e	f	g1	M
		k	k1	d1	l1	k	k1	d1	l1						
63	0.18	212	238	11	23	261	261	285	9	20	10	105	120	172	4
63	0.25	212	238	11	23	239	261	285	9	20	10	105	120	172	4
71	0.37	248	281	14	30	263	295	325	11	23	11	108	136	188	5
71	0.75	248	281	14	30	263	295	325	11	23	11	108	136	188	5
80	0.75	277	315	19	40	310	330	375	19	40	11	125	154	211	6
80	1.5	277	315	19	40	310	330	375	19	40	11	125	154	211	6
90	1.5	329	378	24	50	390	390	432	19	40	13	155	174	227	8
90	2.2	329	378	24	50	348	390	432	19	40	13	155	174	227	8
100	3.0	369	429	28	60	451	433	487	24	50	14	175	192	248	10
100	4.0	369	429	28	60	451	433	487	24	50	14	175	192	248	10
112	5.5	391	448	28	60	456	456	511	24	50	14	175	224	266	10
132S	5.5	452	-	-	-	547	-	-	-	-	16	180	256	326	12
132M	7.5	490	-	-	-	585	-	-	-	-	16	219	256	326	12
160M	11.0	608	-	-	-	-	-	-	-	-	23	264	320	395	16
160L	15.0	652	-	-	-	-	-	-	-	-	23	306	320	395	16

These dimensions are our standard (4-pole), but may vary in individual cases.

## Rotary pulse encoder DIG incremental

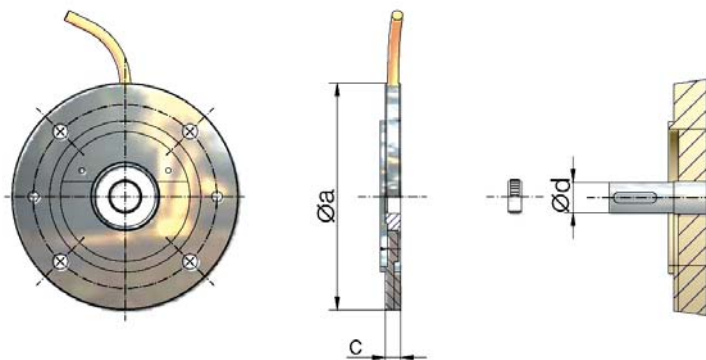
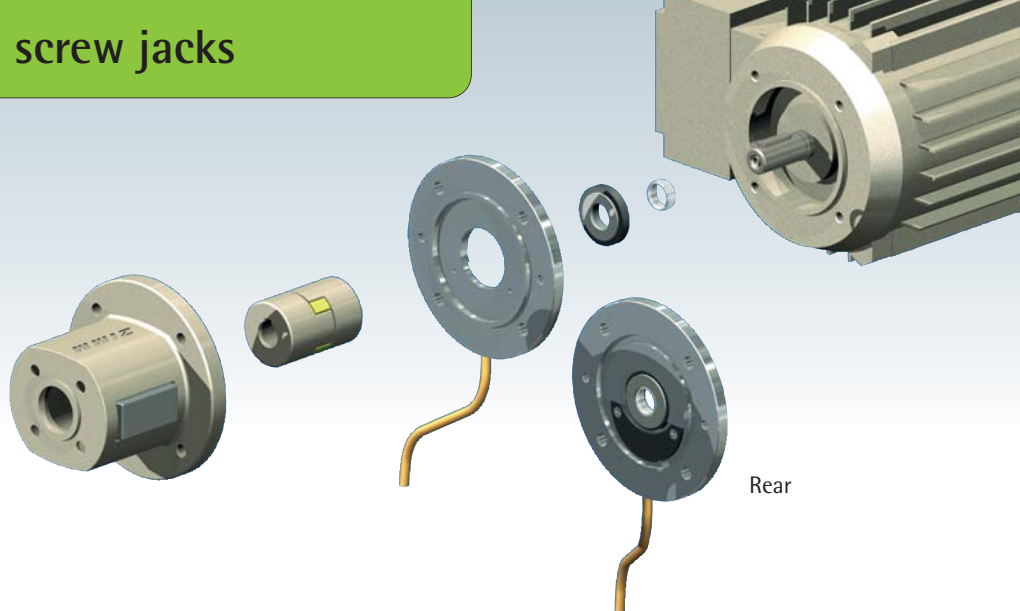

Ordering example:

DIG-160-19-10-HTL

Flange diameter  
Shaft diameter  
Number of pulses  
HTL or TTL

### Rotary pulse encoder DIG

We have developed an intelligent intermediate flange which greatly simplifies recording speed and direction of rotation as well as connecting to supervisory control system. Previously this required complex assembly and additions to the drive system; the intelligent flange achieves this economically and is very easy to fit, even when retrofitting drives.

This magnetic pulse encoder is fitted as an intermediate flange between motor and motor flange. This considerably simplifies the integration of incremental encoders in drive systems, whether for purposes of speed matching, of positioning control (e.g. for dosage control) or for synchronisation. We supply a 2 m cable as standard.

### Advantages

- Compact design (7 to 12 mm thick)
- Simple and quick assembly
- Protected between motor and motor flange
- Protection class IP 20, with appropriate seal IP67
- Universal HTL signal for all conventional evaluations (PNP, NPN, PNP-NPN, RS 422) or TTL
- Short-circuit proof, protected against polarity reversal and protected against overvoltage transmitter electronics in SMD technology; fully integrated into the flange

Motor flange Part no.	Motor	Rotary pulse encoder DIG-Øa-Ød	c	Screw motor side DIN 912	coupling	Available numbers of pulses							Weight kg	
						1	5	10	20	25	50	100 <sup>2)</sup>		
GSZ-2-MF-80-41	56-B14C	DIG-080-09	10	M5x30	KUZ-09-9/9	X	X			X				0.25
GSZ-2-MF-80-41+P-120-10	63-B14B	DIG-120-11	7	M6x30	KUZ-14-9/11	X	X	X	X					0.27
GSZ-2-MF-80-41+P-105-15	71-B14C	DIG-105-14	7	M6x25	KUZ-14-9/14	X	X	X	X					0.25
Z-5-MF-120-60	63-B14B	DIG-120-11	7	M6x30	KUZ-19-11/11	X	X	X	X					0.27
Z-5-MF-105-68	71-B14C	DIG-105-14	7	M6x30	KUZ-19-11/14	X	X	X	X					0.25
Z-10-MF-120-66	63-B14B	DIG-120-11	7	M6x30	KUZ-19-14/11	X	X	X	X					0.27
Z-10-MF-160-75	71-B5	DIG-160-14	7	M8x45	KUZ-24-14/14	X	X	X	X	X	X	X		0.43
Z-10-MF-160-90	80-B14B	DIG-160-19	7	M8x35	KUZ-24-14/19	X	X	X	X	X	X	X		0.43
Z-25-MF-160-105	71-B5	DIG-160-14	7	M8x45	KUZ-28-16/14	X	X	X	X	X	X	X		0.43
Z-25-MF-160-105	80-B14B	DIG-160-19	7	M8x35	KUZ-28-16/19	X	X	X	X	X	X	X		0.43
Z-25-MF-160-105	90-B14B	DIG-160-24	10	M8x40	KUZ-28-16/24	X	X			X	X	X		0.43
Z-25-MF-160-122	100-B14C	DIG-160-28	10	M8x40	KUZ-28-16/28	X	X			X	X	X		0.43
Z-35-MF-160-111	80-B14B	DIG-160-19	7	M8x35	KUZ-24-19L/19	X	X	X	X	X	X	X		0.43
Z-35-MF-160-111	90-B14B	DIG-160-24	10	M8x35	KUZ-24-19L/24	X	X			X	X	X		0.43
Z-35-MF-B + P-200	100-B14B	DIG-200-28	10	M10x40	KUZ-28-19/28	X	X			X	X	X		0.93
Z-35-MF-B + P-200	112-B14B	DIG-200-28	10	M10x40	KUZ-28-19/28	X	X			X	X	X		0.93
Z-50-MF-200-116	90-B5	DIG-200-24	10	M10x55	KUZ-28-20/24	X	X			X	X	X		0.93
Z-50-MF-200-126	100-B14B	DIG-200-28	10	M10x45	KUZ-28-20/28	X	X			X	X	X		0.93
Z-50-MF-200-126	112-B14B	DIG-200-28	10	M10x45	KUZ-28-20/28	X	X			X	X	X		0.93
Z-100/150-MF-200-138	100-B14B	DIG-200-28	10	M10x50	KUZ-28-25/28	X	X			X	X	X		0.93
Z-100/150-MF-200-138	112-B14B	DIG-200-28	10	M10x50	KUZ-28-25/28	X	X			X	X	X		0.93
Z-100/150-MF-B + P-200	132-B14C	DIG-200-38	12	M10x80	KUZ-38-25/38	X	X			X	X	X		0.93
Z-250-MF-200-168	100-B14B	DIG-200-28	10	M10x50	KUZ-38-28L/28L	X	X			X	X	X		0.93
Z-250-MF-200-168	112-B14B	DIG-200-28	10	M10x50	KUZ-38-28L/28L	X	X			X	X	X		0.93
Z-250-MF-200-168	132-B14C	DIG-200-38	12	M10x50	KUZ-38-28L/38	X	X			X	X	X		0.93

NOTE: the fitted key on the motor shaft may have to be shortened.

<sup>2)</sup>Additional charge



## DIG rotary pulse encoder

### Mechanical values

Max. speed	6,000 rpm
Temperature range:	Electronics -40°C to +100°C at $L_{load} \leq 20$ mA (+120°C at $L_{load} \leq 15$ mA) Cable -40°C to +80°C
Flange material / hub material	Aluminium / steel
Connecting cable	PUR sheath / 4 x 0.25 / Ø 5 mm (TTL 6 x 0.14)
Cable length	2 m (other length on request)
Version with plug	4-pin plug / cable length 5 m or 10 m (not for TTL version)
Protection class	dependent on the seal between motor and motor flange (max. IP 67 e.g. when sealed with silicone)
Permissible vibration	100 m/s <sup>2</sup>
Permissible shock	1000 m/s <sup>2</sup>

### Electrical values

	HTL (Standard)	TTL version
Supply voltage	10 to 24V DC / + 20%	5V DC / ± 5%
Max. output frequency	20 kHz	20 kHz
Output signals	Square wave pulses (2-channel) A + B	Square wave pulses (2-channel) A + B and A + B inv.
Pulse sequence	A 90° B Tolerance ± 40° el	A 90° B Tolerance ± 40° el A 90° B inv. Tolerance ± 40° el 180°:180° Tolerance ± 20° el
Pulse/break ratio	180°:180° Tolerance ± 20° el	180°:180° Tolerance ± 20° el
Signal level	$U_{high} \geq U_B - 4V$ at $L_{load} \leq 10$ mA $U_{low} \leq 1$ V	$U_{high} \geq 3.5V$ $U_{low} \leq 0.3V$
Max. load current	≤ 30 mA at $U_B = 10$ V and ≤ 20 mA at $U_B = 24$ V	max. 30 mA
Insulation resistance	100 MΩ	100 MΩ
Insulation test	4 kV	4 kV
Short circuit-proof	yes	no
Protected against polarity reversal	yes	no

When evaluating the signals A + B and A + B inv. and  $U_B = 10 - 24V$  DC  
Please specify when ordering.

### Tests

EMC test to EN 50081-1 (emission) and EN 50082-2 (immunity)

### Connection arrangement

Connection	$U_b$	0 V	A	B	A' (TTL)	B' (TTL)
Cable / 4-core (TTL 6-core)	brown	white	yellow	green	pink	grey
Plug / 4-pin	brown	blue	white	black	-	-

## Spring pressure brake FDB

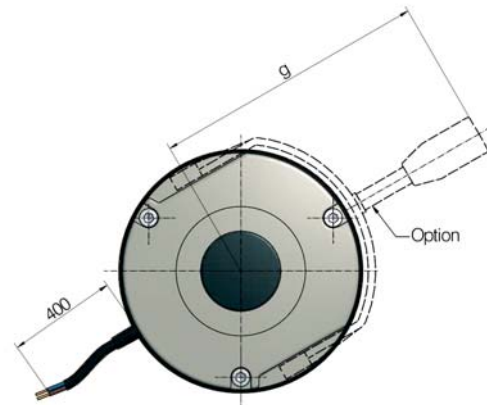
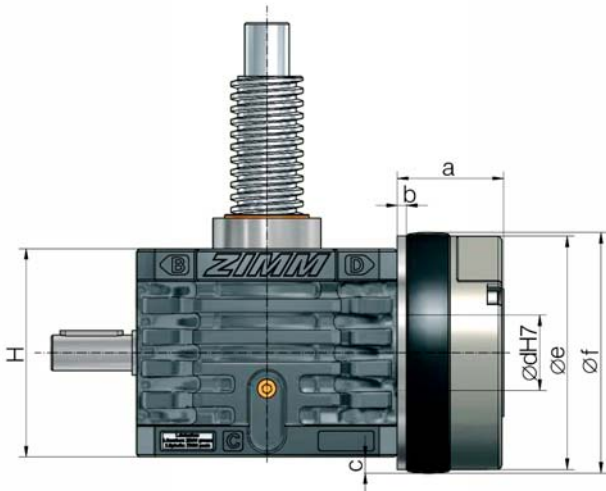
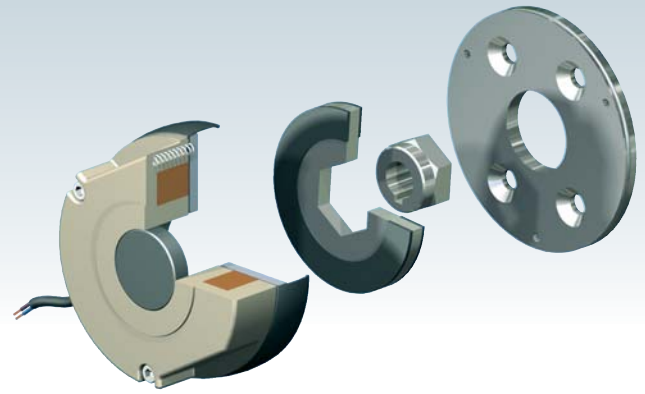

Screw jack size Z/GSZ	Brakes		Braking torque $M_B$ [Nm]	P [W]	H [mm]	Hub $\varnothing$ [mm]	Dimensions							Weight [kg]
	new ZIMM Designation	old ZIMM Designation					a [mm]	b [mm]	c [mm]	d [mm]	e [mm]	f [mm]	g [mm]	
Z-5	FDB 08	FDB 05	5	22	62	11	46	6	13.5	26	85	89	100	1
Z-10	FDB 08	FDB 05	5	22	74	14	46	6	7.5	26	85	89	100	1
	FDB 10	FDB 10	10	28	74	14	54	7	17.5	32	105	109	110	2
Z-25	FDB 10	FDB 10	10	28	82	16	54	7	13.5	32	105	109	110	2
	FDB 13	FDB 20	20	34	82	16	62	9	26.5	42	130	135	130	3
Z-35	FDB 13	FDB 20	20	34	100	19	62	9	17.5	42	130	135	130	3
	FDB 15	FDB 40	40	42	100	19	69	9	27.5	52	150	155	140	5
Z-50	FDB 13	FDB 20	20	34	116	20	62	9	9.5	42	130	135	130	3
	FDB 15	FDB 40	40	42	116	20	69	9	19.5	52	150	155	140	5
Z-100	FDB 15	FDB 40	40	42	160	25	69	9	-	52	150	155	140	5
	FDB 17	FDB 60	60	50	160	25	81	11	7.5	62	170	175	165	7
Z-150	FDB 15	FDB 40	40	42	185	25	69	9	-	52	150	155	140	5
	FDB 17	FDB 60	60	50	185	25	81	11	-	62	170	175	165	7
	FDB 20	FDB 80	100	64	185	25	91	11	8.0	72	195	201	186	10
Z-250	FDB 17	FDB 60	60	50	204	28	81	11	-	62	170	175	165	7
	FDB 23	FDB 150	150	76	204	28	101	11	13.5	80	225	231	196	15
Z-350	FDB 20	FDB 80	100	64	230	38	91	11	-	72	195	201	186	10
	FDB 26	new!	250	100	230	38	113	11	17.0	-	258	264	285	22

**i** Other brakes up to Z-1000 available on request.

$$\text{For DC: } P = U \cdot I \rightarrow I = \frac{P}{U}$$

e.g.: FDB 17 at 205V DC coil voltage

$$I = \frac{50W}{205V} = 0.24 \text{ A}$$



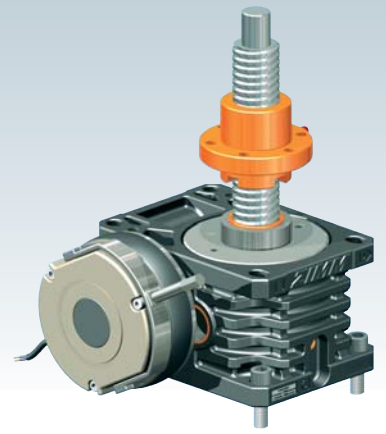

## Spring pressure brake FDB

### Function

A spring pressure brake is used:

- when there is a lack of self-locking characteristics (high-pitch, double-pitch screws, ball screws KGT)
- where self-locking characteristics are doubtful (as a safety precaution)
- for increased accuracy of stopping position, independent of the lubrication situation

### General

The braking torque is generated by compression springs when the brake is deenergised. The brake is released electromagnetically by the application of DC voltage. The protective rings shield the friction faces from external influences. The standard version has protection class IP 54.

### Mode of operation

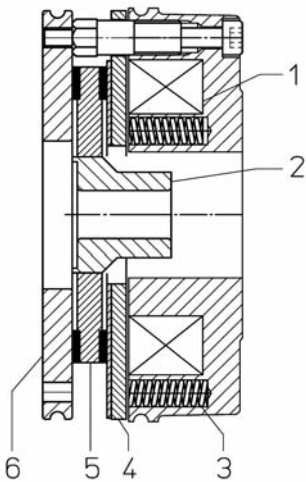

The compression springs (3) exert force on the armature disc (4) which is free to move axially and which presses the brake rotor (5) against the flange (6). The brake rotor in turn is tightly mounted on the hub (2).

The shaft is then braked. Application of DC voltage to the field windings (1) in the magnetic body generates a magnetic force which pulls the armature disc towards the magnetic body. The brake rotor is freed and the brake is released.

In the event of an emergency stop or a power failure, the spring pressure brake ensures that the load is safely braked to a stop.

### Electrical supply

The spring pressure brake requires a DC supply. Half-wave and bridge rectifiers are available to provide the power supply to the brakes from the AC mains supply.

Because of the inductance of the solenoid coil, the release of the armature disc on loss of power is not immediate. When the switching off takes place in the AC line from the rectifier, this delay is relatively long.

The delay in switching off can be reduced if the connections available between the rectifier are used to switch the DC line (6 times faster).

If the switching is performed on the AC side, a bridge should be made to the switch contacts.

### Manual release

If a manual release lever is fitted, the brake can be released mechanically, e.g. in the event of a power failure.

### Brake voltage

The brake voltage is derived from the mains phase voltage. For braked motors, the brake voltage is generally derived from the motor voltage in delta arrangement. The operating voltage of the brake is indicated on the solenoid casing.

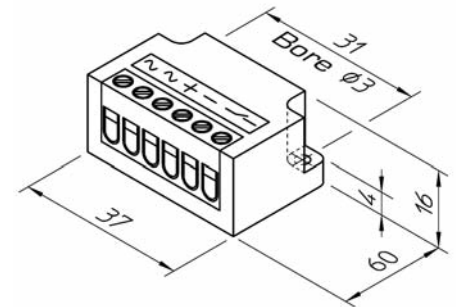

Supply voltage	Brake operating voltage	Rectifier
24V DC	24V DC	-
230V AC	205V DC	GLB Bridge rectifier (PMB 400-S)
230V AC 400V AC 500V AC	105V DC 180V DC 220V DC	GLE Half-wave rectifier (KSE 500/1-S)

 All parts are corrosion-resistant!

### Ordering example:

Gearbox size \_\_\_\_\_  
 Brake size \_\_\_\_\_  
 Brake operating DC voltage \_\_\_\_\_  
 Rectifier type (if required) \_\_\_\_\_  
 Manual release HL (if required) \_\_\_\_\_

Z-25-FDB 10-205V DC-GLB-HL



## Lubrication - screw



### Lubricants

Always use the correct lubricants for a long service life!  
These lubricants have been carefully selected to suit the screw jack requirements.  
Caution should be exercised in using other greases! A "good" grease may not always be the "right" grease.

#### Trapezoidal screw

Inspect the trapezoidal screw regularly and regrease it depending on the operating cycle. Use the grease that we recommend. These greases are ideally matched to the operating requirements of our screw jack systems.



#### Standard grease:

Castrol Tribol GR 4020/460-2 PD (up to size 150)  
Castrol Tribol GR 3020/1000-2 PD (from size 250)

As well as the standard greases we also offer greases for special applications:

- High temperature/high duty cycle
- Low temperature
- Heavy duty
- Food industry
- Clean room
- Vacuum, etc.

Most greases are available ex stock. The exact application and the load cycles are important when making the selection. The best strategy is to send us the completed enquiry checklist (Section 7).

The important question is whether it matches the respective requirements.

#### Ball screw KGT

Lubricate the ball screw KGT every 300 hours of effective operation. For heavy-duty systems every 100 hours.



#### Grease quantity:

Guidance value approx. 1 ml per cm screw diameter.

#### Standard grease:

Castrol Tribol GR 4747/220-2 HT



#### Ordering example:

Castrol Tribol GR 4020/460-2 PD,  
Cartridge 400g

### Automatic lubricator Z-LUB

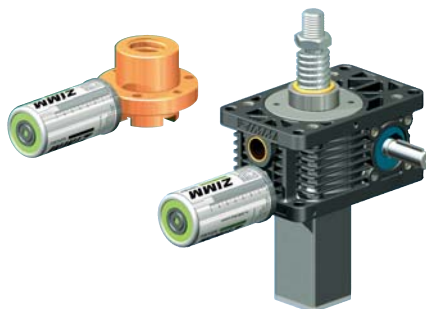
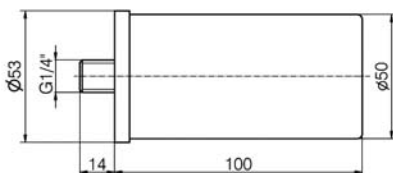

The ZIMM lubricator Z-LUB continuously supplies the screw with lubricant. The Z-LUB is activated when the run-time is set (1 to 12 months at 20°C) (gas generation cell). The filling level can be viewed all the time in the transparent housing.  
Suitable for ball screws under certain conditions.

Metering time:	1 to 12 months, infinitely adjustable
Volume:	125 ml
Operating temperature:	+5°C to +55°C (standard grease, mineral-based) for synthetic greases down to -20°C
Thread:	G1/4"
Greases:	ZIMM screw greases



#### Ordering example:

Z-LUB, ZIMM lubricator  
Filling: Castrol Tribol GR 4020/460-2 PD



#### Ordering example:

Reducer to G 1/8":  
Part no. MSZ-SG-RS1



Infinitely adjustable from 1 to 12 months metering time

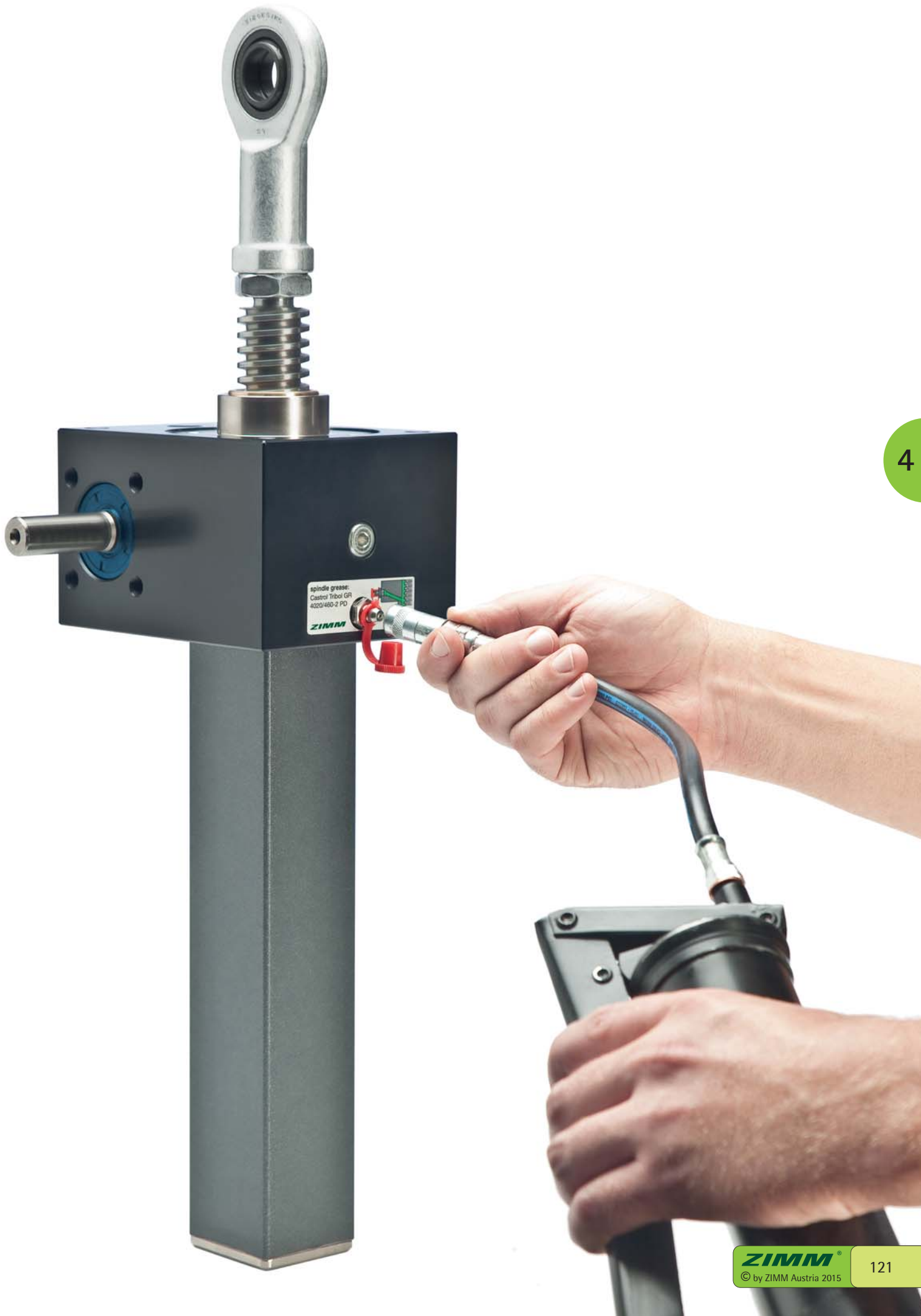

## KSZ and KGZ – Advantages

Same mounting height – no support plates required

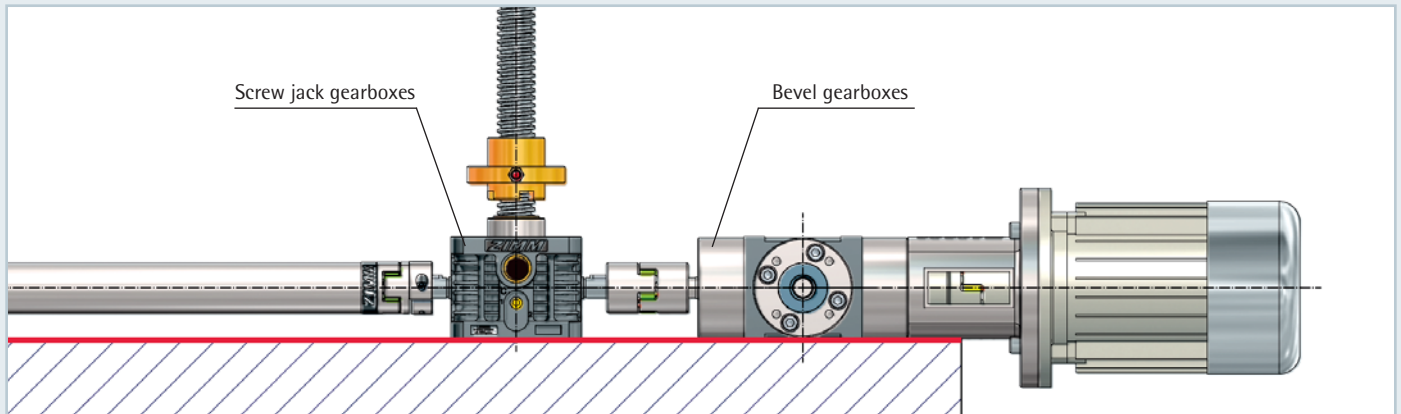

ZIMM bevel gearboxes KSZ and KGZ have the same installation height as the ZIMM screw jack gearbox.

No support plates are required.

Suitable for standard – motor flanges

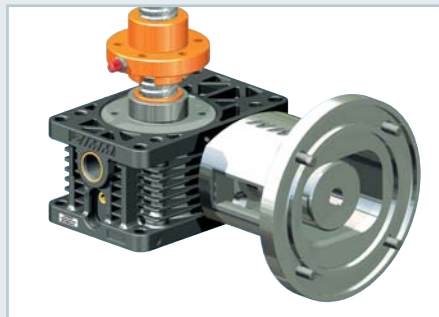
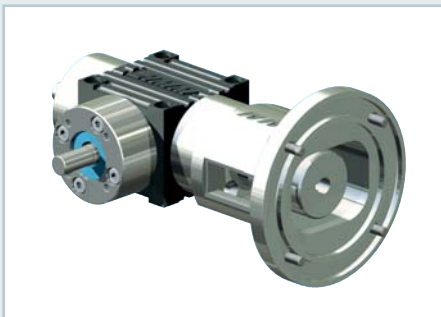

Bevel gearboxes and screw jack gearboxes have the same motor flange fixing pattern.

See Section 4 for standard flanges.

## Bevel gearboxes

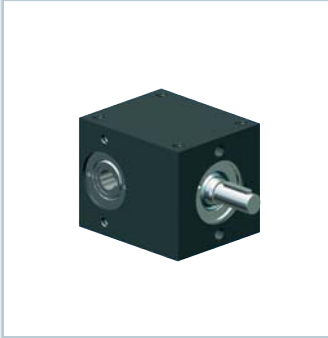

KSZ-2  
spiral-toothed

Page 124



KGZ  
straight-toothed

Page 126



KSZ  
spiral-toothed

Page 127

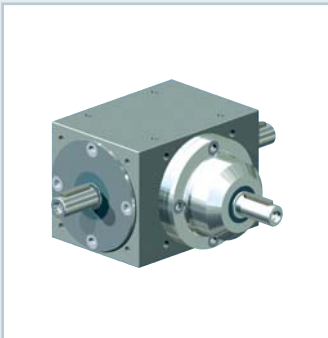

KST  
High-performance gearbox  
spiral-toothed

Page 128

## KSZ-2 layout examples



The KSZ-2 is a bolt-on gearbox and therefore where larger screw jacks are used the layouts will be different.

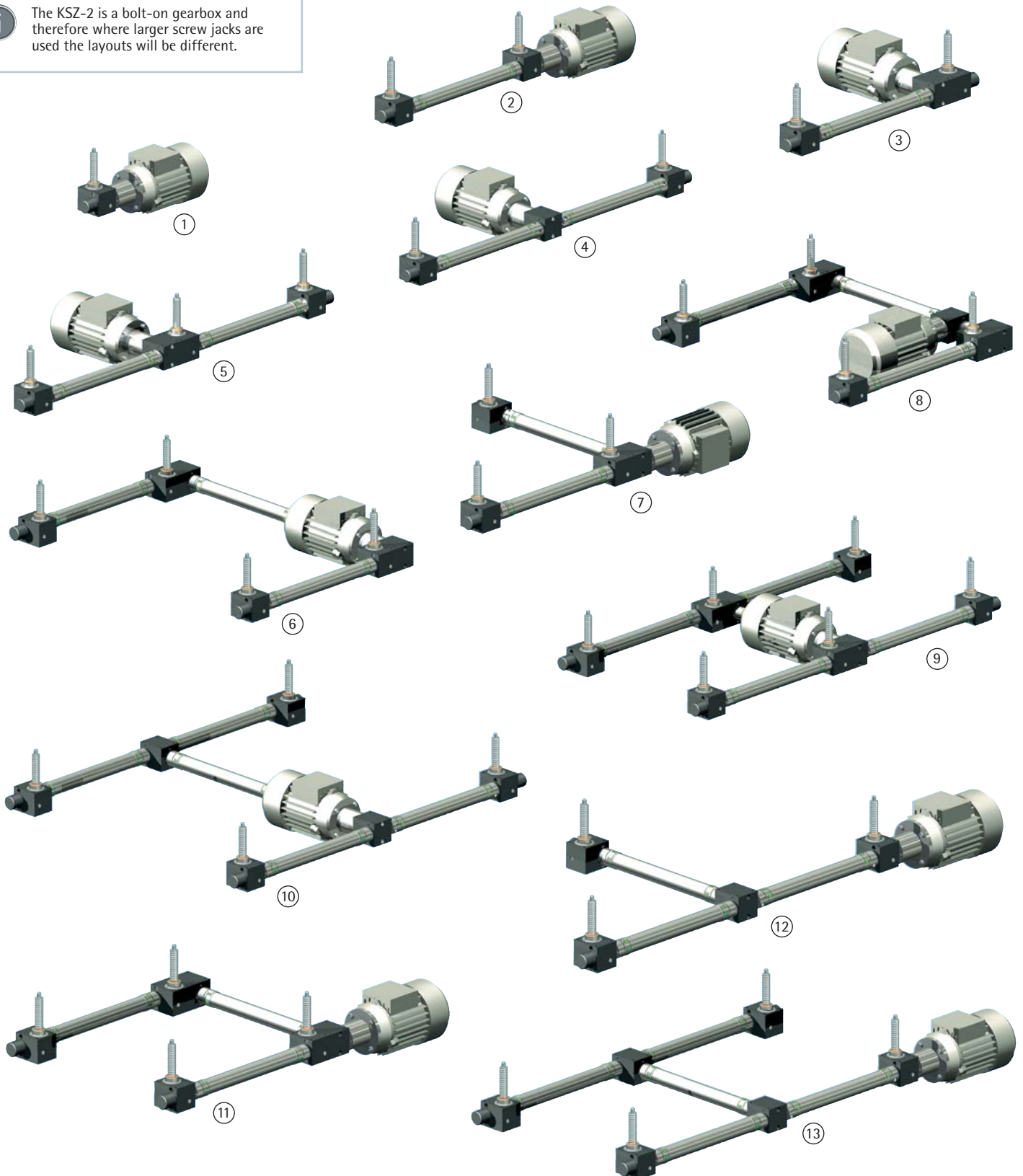

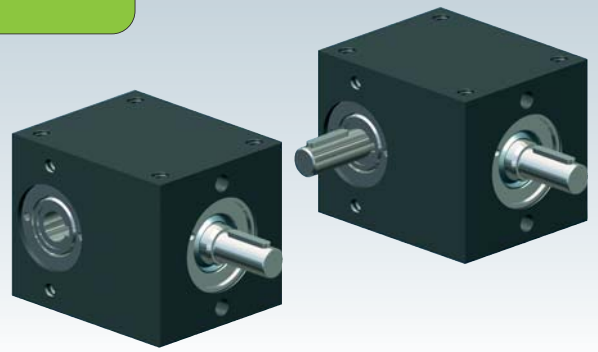

## KSZ-2 bevel gearbox

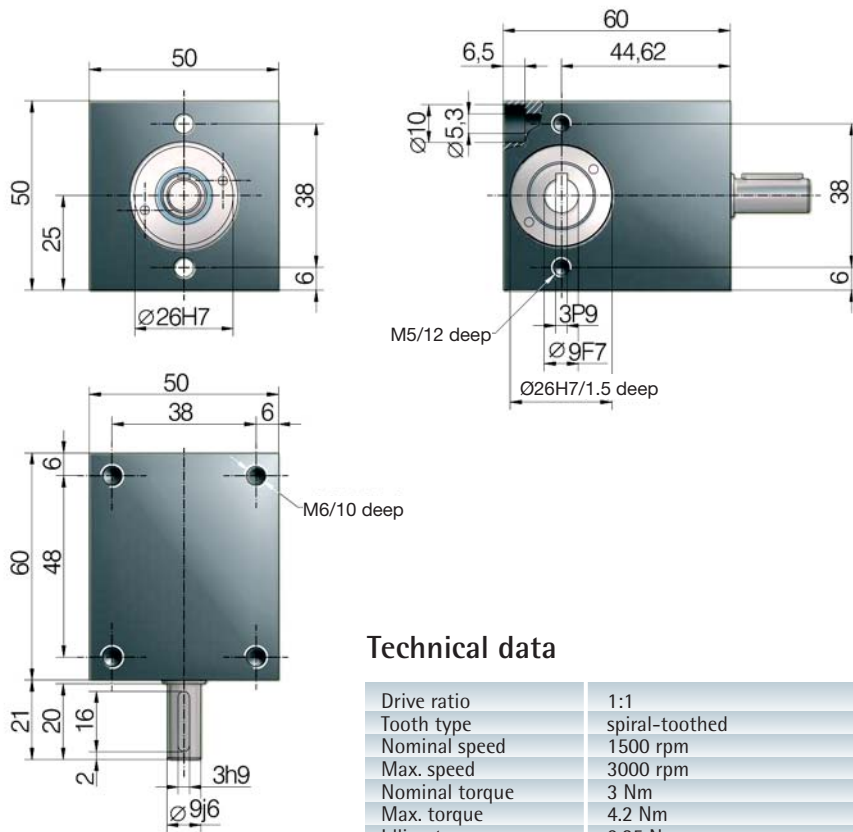

### Technical data

Drive ratio	1:1
Tooth type	spiral-toothed
Nominal speed	1500 rpm
Max. speed	3000 rpm
Nominal torque	3 Nm
Max. torque	4.2 Nm
Idling torque	0.25 Nm
Duty factor	up to 40%
Lubricant	fluid grease
Weight	0.45 kg
Housing material	hard anodised aluminium
Shaft material	stainless steel



Part no.: KSZ-2

### Spiral-toothed

Spiral toothing ensures high torque and low running noise

### Bolt-on, shaft-mounted gearbox

The KSZ-2 has a continuous hollow shaft. Thus it can easily be bolted on to the Z-2 screw jack gearbox and requires very little space.

### Easy bolt-on assembly:

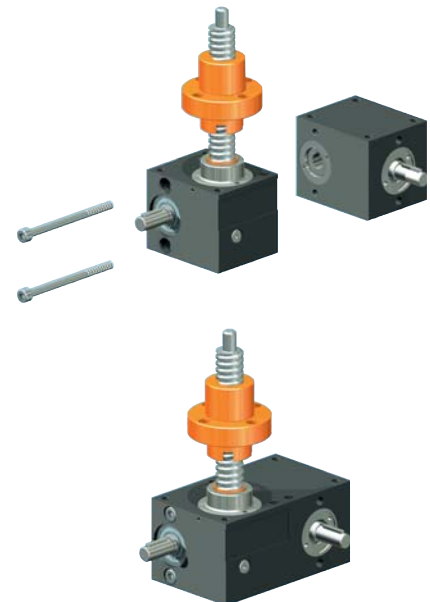

Part no.: 2 bolts DIN 912 M5x55, A4

### Stub shaft

Fitting a stub shaft allows the KSZ-2 to be used as a conventional right-angle gearbox.

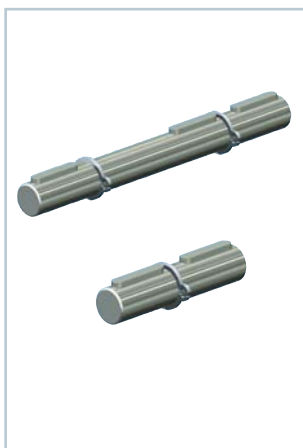

### Stub shaft T (long)

Material:  
stainless steel

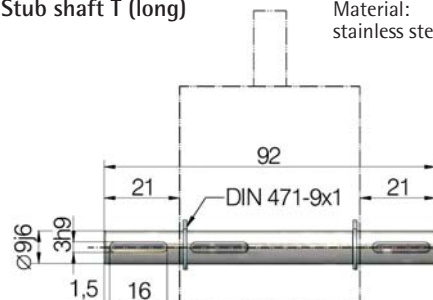

Part no.: KSZ-2-STW-T

### Stub shaft L (short)

Material:  
stainless steel

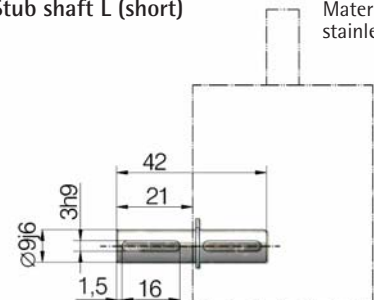

Part no.: KSZ-2-STW-L

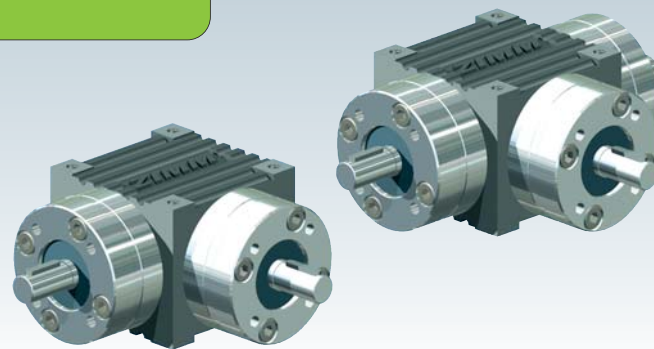

## KGZ straight-toothed

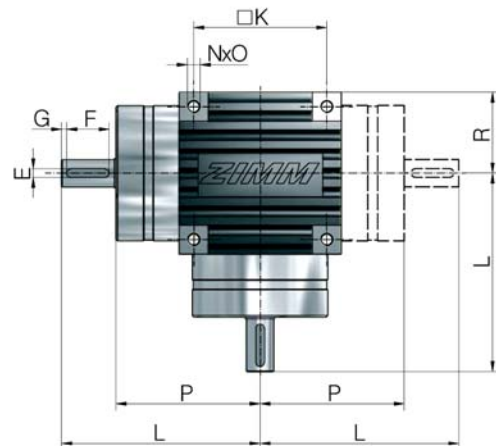
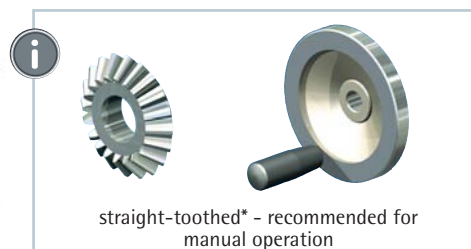
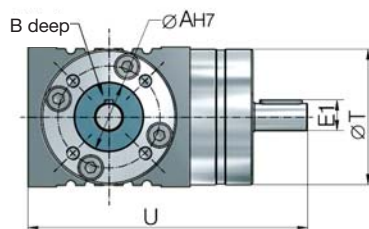
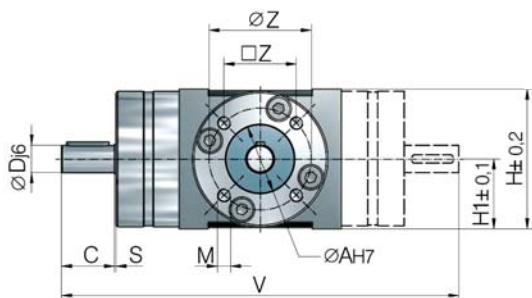

### Shaft configuration

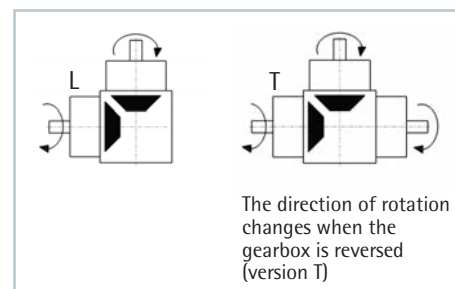

If one of the shafts is vertical, this must be stated when ordering: e.g.: "vertical drive shaft"

### Dimensions

Part no.	Ø AH7	B	C	Dj6	En9	E1	F	G	H	H1	□K	L	L1	M	N	O	P	R	S	Ø T	U	V	Ø Z	□ Z
KGZ-5-L/T-1	32	2	21	11	4	11.5	16	3	62	31	60	90	30	M6	M6	13	69	36.0	1.0	61.5	126.0	180	46.1	32.5
KGZ-25-L/T-1	40	3	31	16	5	18.0	25	3	82	41	78	117	39	M8	M8	15	86	47.5	1.5	80.0	164.5	234	60.0	42.0

### Technical data

Size	Permissible torque [Nm] at 10 to 1500 rpm		Moment of inertia Torque [kg cm <sup>2</sup> ]		Permissible radial load F <sub>R</sub> [N] at the shaft end at n <sub>1</sub> [rpm]				Weight [kg]	
	L version	T version	L	T	500	750	1000	1500	L	T
KGZ-5	6.5	7.5	0.429	0.565	250	210	180	150	2.7	3.4
KGZ-25	14.0	16.0	1.283	1.569	600	500	450	360	5.7	7.0

### Material specifications

- Housing material: GGL 20
- Bevel gears: straight-toothed, gas nitrided
- Roller bearings
- Permanent lubrication with oil
- Temperature range -10°C to +90°C

- Drive ratio  $i = 1:1$
- Maximum speed 1500 rpm
- Duty factor 20% (max.)
- Repair: change complete gearbox
- In the upper speed range, values of 90 to 100 dBA may occur



### Ordering example:

KGZ-25-T-1

Bevel gearbox  
straight-toothed  
Size  
Shaft configuration T-1 or L-1

\*KGZ straight-toothed gearboxes are especially suitable for manual operation or infrequent motorised operation. Running noise is higher in comparison with KSZ spiral-toothed bevel gearboxes. KGZ has the same dimensions as KSZ.



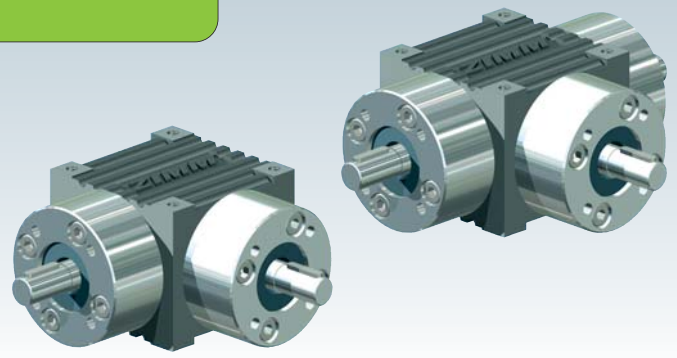

## KSZ spiral-toothed

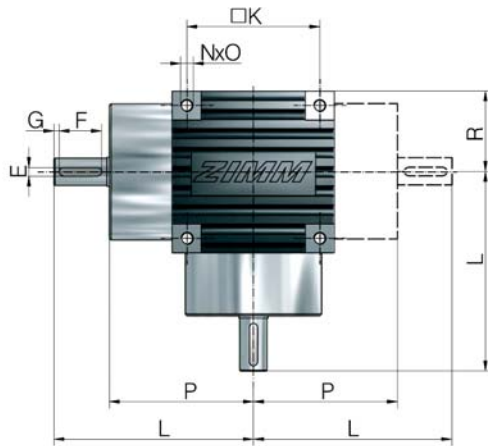
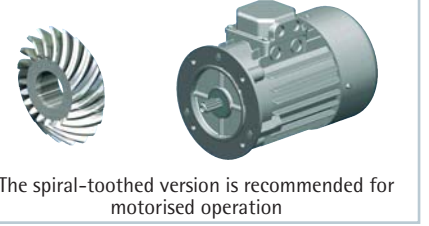
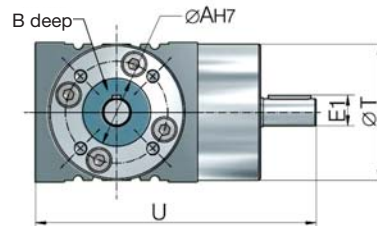
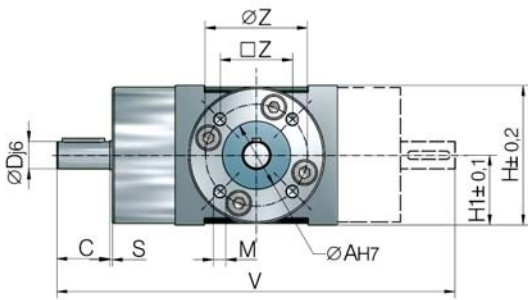

## Shaft configuration

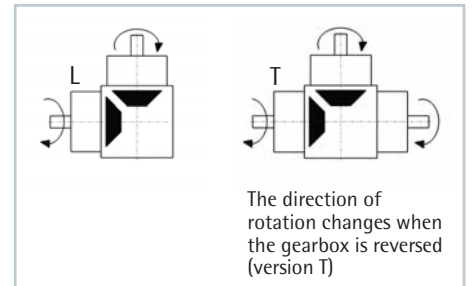

If one of the shafts is vertical, this must be stated when ordering: e.g.: "vertical drive shaft"

## Dimensions

Part no.	$\varnothing A_{H7}$	B	C	$D_{j6}$	$E_{H9}$	$E_1$	F	G	H	$H_1$	$\square K$	L	$L_1$	M	N	O	P	R	S	$\varnothing T$	U	V	$\varnothing Z$	$\square Z$
KSZ-5-L/T	32	2	21	11	4	12.5	16	3	62	31	60	90	30	M6	M6	13	69	36.0	1.0	61.5	126.0	180	46.1	32.6
KSZ-10-L/T	35	3	26	14	5	16.0	16	5	74	37	70	105	35	M8	M8	15	79	42.5	1.5	73.5	147.5	210	49.5	35.0
KSZ-25-L/T	40	3	31	16	5	18.0	25	3	82	41	78	117	39	M8	M8	15	86	47.5	1.5	80.0	164.5	234	60.0	42.4
KSZ-50-L/T	52	4	39	20	6	22.5	25	5	116	58	110	165	55	M10	M10	15	126	67.5	2.0	115.0	232.5	330	86.0	50x70

## Technical data

Bevel gearbox	Permissible torque [Nm] at various speeds [rpm]						Moment of inertia [kg cm <sup>2</sup> ]		$F_{\text{radial}}$ [N]	Weight [kg]
	0	10	100	750	1500	3000	L	T		
KSZ-5-L/T	29.5	13.9	13.9	13.8	13.5	13.3	0.429	0.565	140	L 2.7 T 3.4
KSZ-10-L/T	58.4	25.4	25.2	25.1	23.1	19.1	1.129	1.436	200	L 4.5 T 5.6
KSZ-25-L/T	82.4	32.9	32.9	32.7	30.1	24.1	1.283	1.569	300	L 5.7 T 7.0
KSZ-50-L/T	343.0	143.3	143.1	119.3	95.8	75.3	10.008	12.596	1100	L 19.6 T 21.8

### Manufacturing and quality features:

- Housing material: GGL 20
- Low-backlash version
- Quiet running
- High torque transmission in a small size
- Spiral-toothed bevel gears:
- Pre-loaded taper roller bearings
- Drive ratio  $i = 1:1$

- Permanent lubrication with oil; oil change required only on heavy duty applications
- Sealing by means of shaft seals and O-rings
- Max. 40% duty factor at 1500 rpm
- Compatible with screw jack modular components
- All installation dimensions symmetrical
- Shaft ends are identical to those for screw jack gearboxes of the same size



### Ordering example:

Bevel gearbox  
spiral-toothed  
Size  
T or L shaft configuration

KSZ-25-T

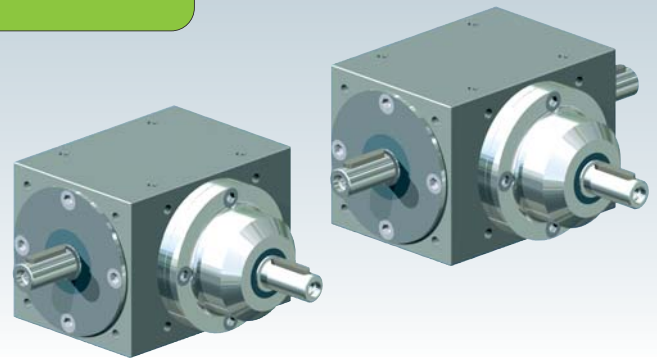

## KST high-performance gearbox

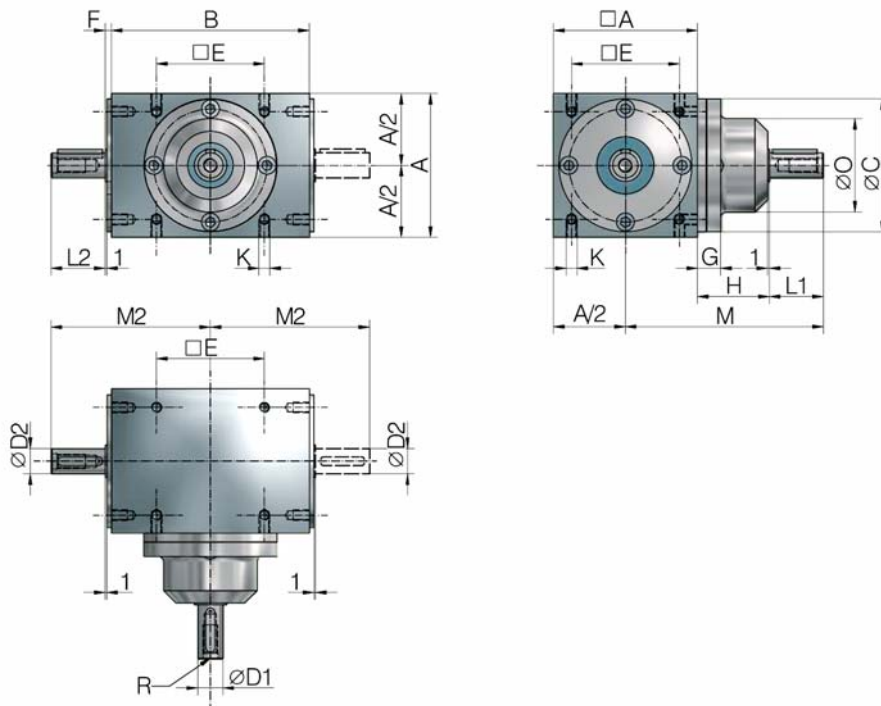

If one of the shafts is vertical, this must be stated when ordering: e.g.: "vertical drive shaft"

**CAUTION:**

Dimensions are for a 1:1 drive ratio.  
Dimensions may differ for other ratios.  
Please ask for a dimension data sheet.

Gearbox size	□A	B	C <sub>17</sub>	D <sub>1j6</sub> D <sub>2j6</sub>	□E	M	M <sub>2</sub>	L <sub>1</sub> L <sub>2</sub>	F	G	H	K	R	O	DIN 6885 key
KST-000	60	73	59	12	46	89	66.0	23	5.5	11	36	M5	M5	42	4x4
KST-00	80	110	74	14	60	110	88.5	30	2.5	13	40	M6	M6	52	5x5
KST-01	110	145	102	22	82	135	111.0	35	2.5	14	45	M8	M8	70	6x6
KST-A1	140	175	130	32	105	165	137.0	45	3.5	14	50	M10	M10	90	10x8
KST-B1	170	215	160	42	130	210	172.0	60	3.5	18	65	M12	M12	110	12x8
KST-C1	210	260	195	55	160	275	220.0	85	4.0	18	85	M16	M16	135	16x10
KST-D1	260	330	245	65	200	340	270.0	100	4.0	23	110	M16	M16	150	18x11
KST-E1	330	430	310	75	260	435	340.0	120	4.0	29	150	M20	M20	230	20x12

$$K_{\text{deep}} = K \cdot 1.5$$

**Quality features**

- Extremely quiet operation
- Maintenance-free, with minimum backlash
- High torques in relation to size
- High duty factor or continuous operation
- High concentricity
- Suitable for the most demanding applications

**Manufacturing features**

- Spiral bevel gears, palloid-toothed, case-hardened, precision lapped as pairs
- Tooth contact mechanically adjusted to +/- 15µ
- Roller bearings tested for noise
- GD250 (Meehanite) cast-iron housing, low-distortion with good torsional stiffness
- Radial shaft seals with dust lip

- Oil filling: synthetic oil HT68, permanent lubrication
- Standard drive ratio  $i = 1:1$ , other ratios on request  
(CAUTION: Dimensions may change)

## KST high-performance gearbox

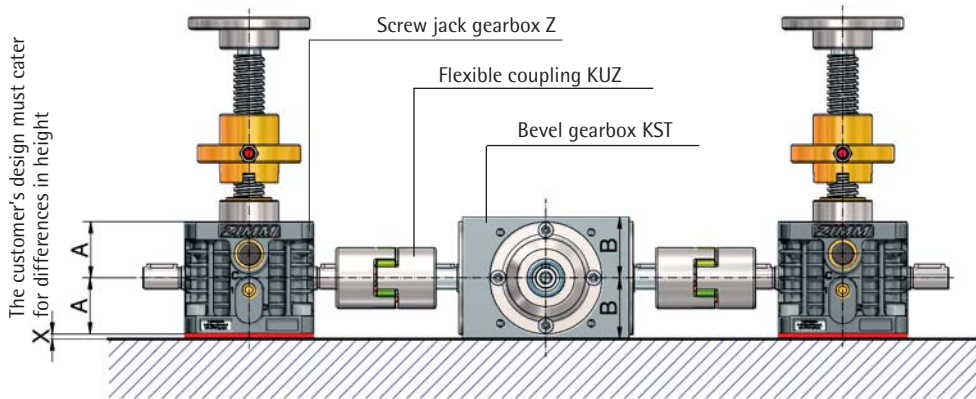

Size	Permissible torque [Nm]			Permissible radial load $F_R$ [N] at the shaft end		Weight [kg]
	max. $M_d$	1500 rpm	3000 rpm	$d_1$	$d_2$	
KST-00	80	28	20	300	300	5
KST-01	200	65	50	1100	1100	11
KST-A1	380	130	95	1500	2700	21
KST-B1	620	230	160	2000	3700	36
KST-C1	1200	390	-	3250	5000	64
KST-D1	2000	740	-	3800	7500	124
KST-E1	3500	1300	-	4500	9200	250

**Special instructions:**

If the duty factor is more than 20% and the speed is more than 3000 rpm, you should specify a grease and oil level inspection glass when ordering.

The KST bevel gearbox is available on request with drive ratios of 1:2 (higher output speed) to 6:1 (lower output speed) and as a flanged gearbox for direct attachment to your motor or servomotor.

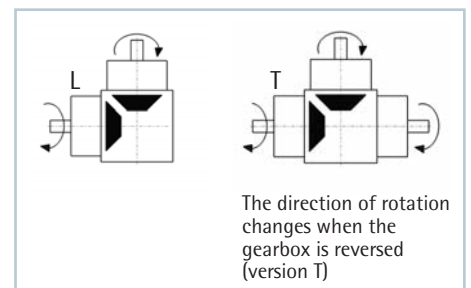
**Shaft configuration****Ordering example:**

Bevel gearbox  
spiral-toothed  
Size  
T or L shaft configuration  
Drive ratio 1:1 (other ratios on request)

**KST-01-L-1:1**

# Everything on the move

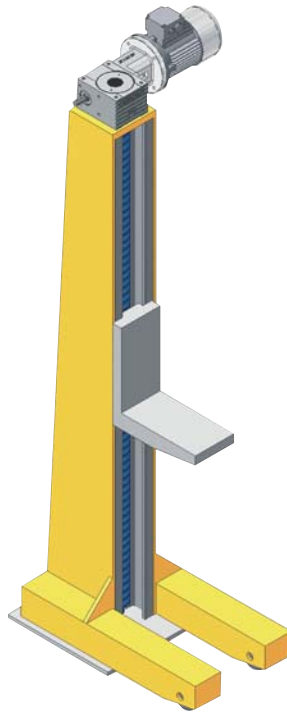
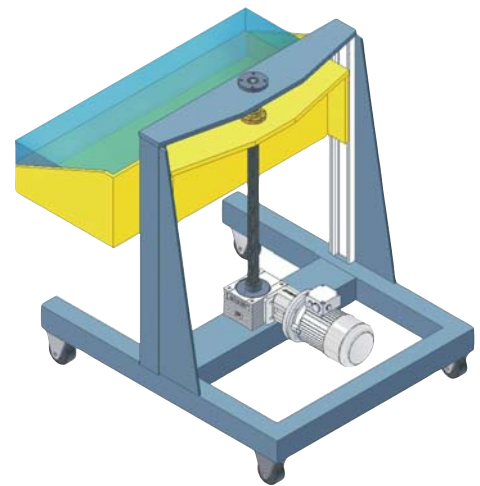

...combinations of  
screw jacks and  
linear guides

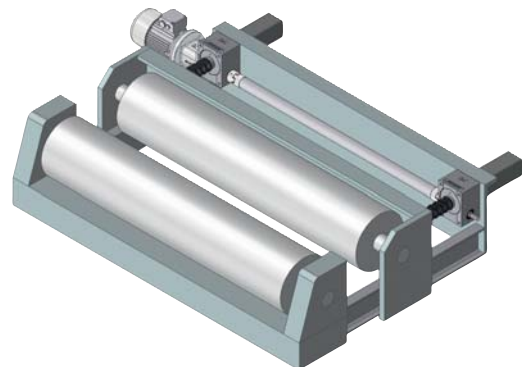
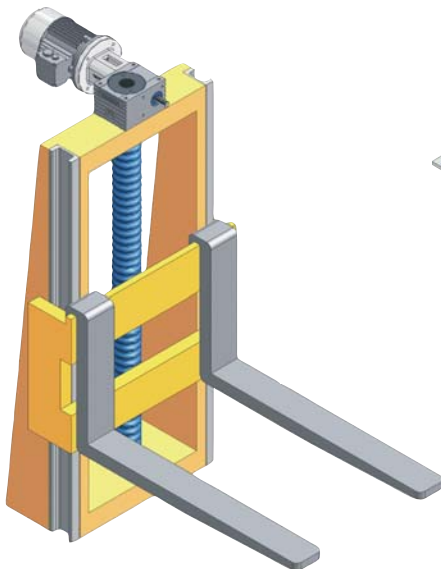

**Material:**

18MnNb 6 with significantly higher load carrying capacity due to the use of niobium (Nb):

- Higher wear resistance
- Fine-grain structure
- Very suitable for welding

**Delivery versions:****Standard:**

bright rolled

ZUP ---.0700

**On request:**

precision straightened  $\pm 0.3$  mm/m

ZUP ---.0701

sandblasted

ZUP ---.0702

sandblasted + precision straightened

ZUP ---.0703

special processing with drawing on request

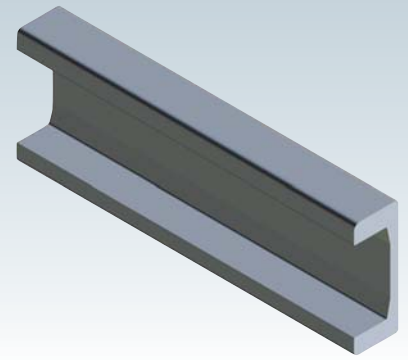
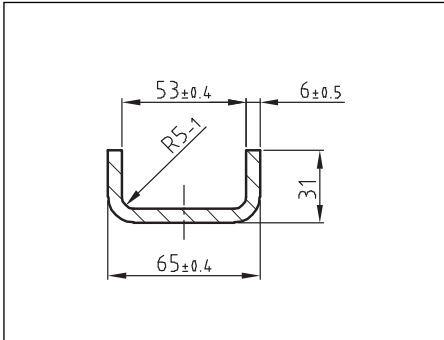
**U-profiles**

**ZUP 050.0730 (Standard S)**

Weight: 5.3 kg/m

Wx: 11.8 cm<sup>3</sup> lx: 38.5 cm<sup>4</sup>

Wy: 2.5 cm<sup>3</sup> ly: 5.1 cm<sup>4</sup>

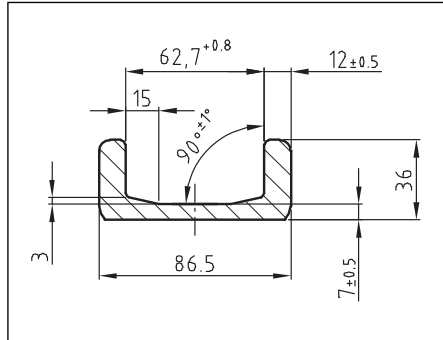

**ZUP 060.0700 (Standard 0 Nb)**

Weight: 10.5 kg/m

Wx: 32 cm<sup>3</sup> lx: 139 cm<sup>4</sup>

Wy: 6 cm<sup>3</sup> ly: 16 cm<sup>4</sup>

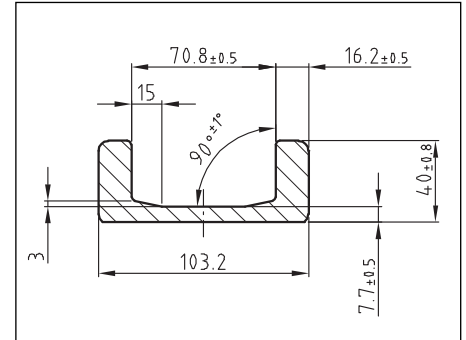

**ZUP 070.0700 (Standard 1 Nb)**

Weight: 14.8 kg/m

Wx: 53 cm<sup>3</sup> lx: 276 cm<sup>4</sup>

Wy: 11 cm<sup>3</sup> ly: 29 cm<sup>4</sup>

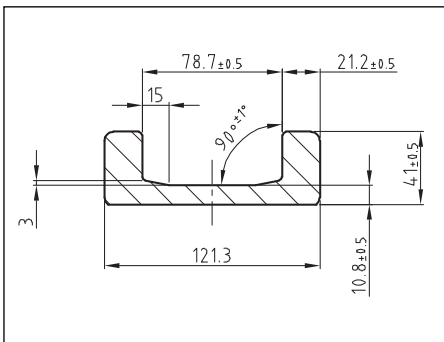

**ZUP 080.0700 (Standard 2 Nb)**

Weight: 20.9 kg/m

Wx: 81 cm<sup>3</sup> lx: 495 cm<sup>4</sup>

Wy: 15 cm<sup>3</sup> ly: 39 cm<sup>4</sup>

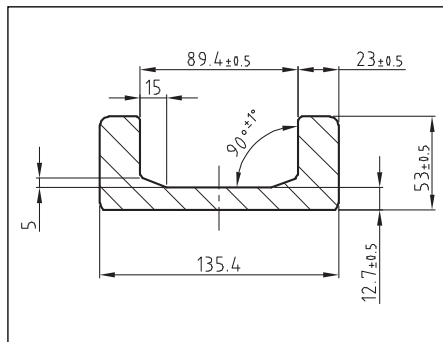

**ZUP 090.0700 (Standard 3 Nb)**

Weight: 28.6 kg/m

Wx: 130 cm<sup>3</sup> lx: 865 cm<sup>4</sup>

Wy: 31 cm<sup>3</sup> ly: 89 cm<sup>4</sup>

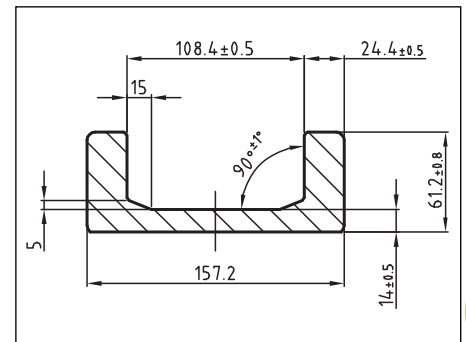

**ZUP 110.0700 (Standard 4 Nb)**

Weight: 36 kg/m

Wx: 190 cm<sup>3</sup> lx: 1491 cm<sup>4</sup>

Wy: 39 cm<sup>3</sup> ly: 149 cm<sup>4</sup>

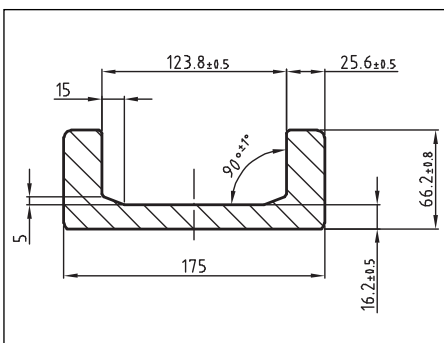

**ZUP 120.0700 (Standard 5 Nb)**

Weight: 42.8 kg/m

Wx: 251 cm<sup>3</sup> lx: 2192 cm<sup>4</sup>

Wy: 51 cm<sup>3</sup> ly: 212 cm<sup>4</sup>

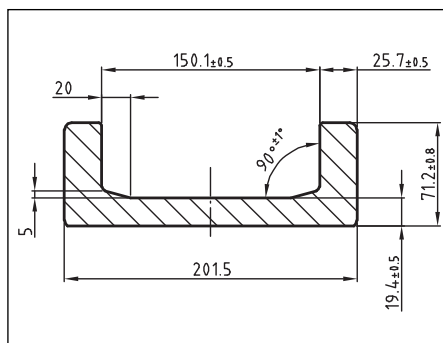

**ZUP 150.0700 (Standard 6 Nb)**

Weight: 52.3 kg/m

Wx: 342 cm<sup>3</sup> lx: 3432 cm<sup>4</sup>

Wy: 57 cm<sup>3</sup> ly: 273 cm<sup>4</sup>

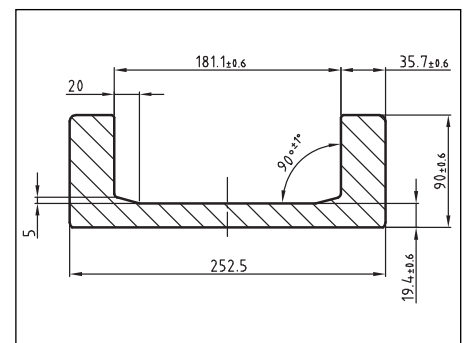

**ZUP 180.0700 (Standard 8 Nb)**

Weight: 78.51 kg/m

Wx: 682.2 cm<sup>3</sup> lx: 8612.5 cm<sup>4</sup>

Wy: 223.4 cm<sup>3</sup> ly: 720.2 cm<sup>4</sup>

**Ordering example:**

**ZUP 070.0700**

U-profile with internal size 70.8 mm,  
bright rolled

Lubricated for life, but optionally from size 60 suitable for relubrication

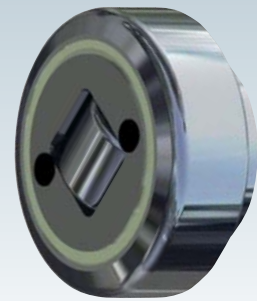

## Combination, bearings, combined – fixed

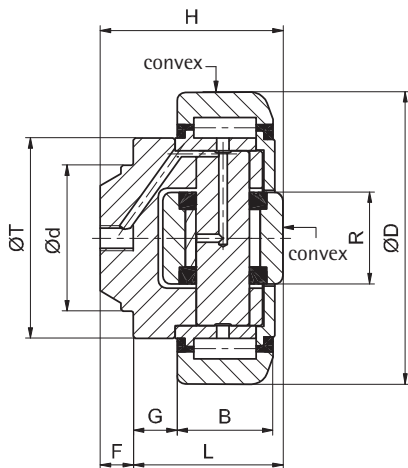

**i** Technical specifications bearing / profile, based on Hertzian pressure  $F_R$  and  $F_A$ . The contact faces of the combination bearings have a convex finish. Bearings with diameter  $<100$  mm should be dismantled before welding is performed.



### Ordering example:

ZTR 090.0200  
Combination bearings, combined – fixed,  
Ø 88.4 mm

Part no.	D	d	H	B	G	L	F	T	R	$F_R$	$F_A$	dyn. load factor of radial bearings C	stat. load factor of radial bearings $C_0$	dyn. load factor of axial bearings $C_a$	stat. load factor of axial bearings $C_{0a}$	U-profiles
	mm	mm	mm	mm	mm	mm	mm	mm	mm	mm	mm	kN	kN	kN	kN	
ZTR 050.0200	52.5	30	33	17	5	27	6	40	16	5.3	2	24.5	32.5	7.5	7.5	ZUP 050.0726
ZTR 060.0200	62.5	30	37.5	20	9	30.5	7	42	20	8.87	2.95	31	35.5	11	11.5	ZUP 060.0700
ZTR 070.0200	70.1	35	44	23	10.5	36	8	48	22	11.4	3.15	45.5	51	13	14	ZUP 070.0700
ZTR 080.0200	77.7	40	48	23	10.5	36.5	11.5	54	24	12.87	5	48	56.8	18	18	ZUP 080.0700
ZTR 090.0200	88.4	45	57	30	10.5	44	13	59	26	20.37	5.1	68	72	23	23	ZUP 090.0700
ZTR 110.0200	107.7	60	69	31	20	55	14	71	34	24.06	8.9	81	95	31	36	ZUP 110.0700
ZTR 120.0200	123	60	72.3	37	14	56	16.3	80	40	33.44	9.8	110	132	43	50	ZUP 120.0700
ZTR 150.0200	149	60	78.5	45	8.5	58.5	20	103	50	51.94	17.4	151	192	68	71	ZUP 150.0700
ZTR 180.0200	180	100	95.7	57.3	12.5	76.3	19.4	124	60	76	23	207	243	73	83	ZUP 180.0700

## Combinations

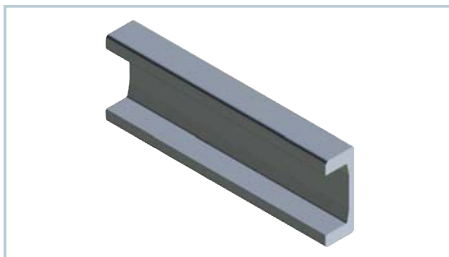

### ZUP ---.0700

See page 131 for the appropriate guide profiles in Nb quality

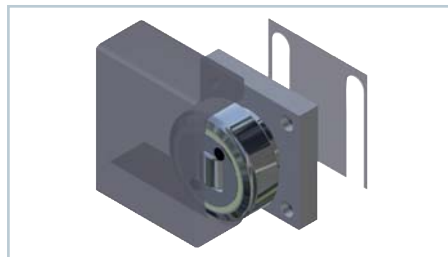

### ZBQ ---.1000

See page 134 for square attachment elements with welded-in combination bearings

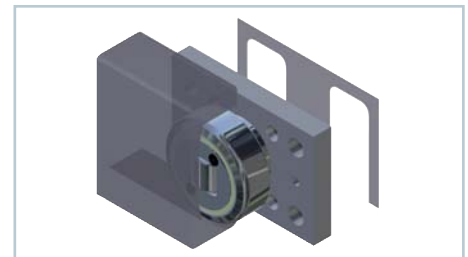

### ZBR ---.1100

See page 135 for rectangular attachment elements with welded-in combination bearings

Sealed for life

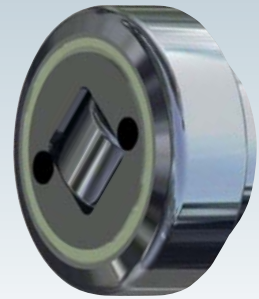

## Combination bearings, combined – adjustment with eccentric cam

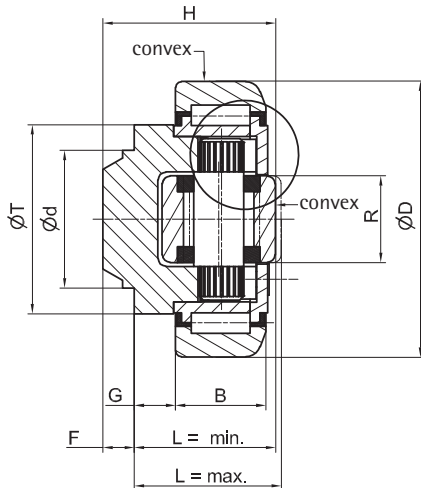

**i** Technical specifications bearing / profile, based on Hertzian pressure  $F_R$  and  $F_A$ . The contact faces of the combination bearings have a convex finish. Bearings with diameter <100 mm should be dismantled before welding is performed.

**🛒** **Ordering example:**

ZTR 090.0350  
Combination bearings, combined –  
adjusted with eccentric cam, Ø 88.4 mm

Part no.	D	d	B	G	L <sub>min</sub>	L <sub>max</sub>	F	T	R	F <sub>R</sub>	F <sub>A</sub>	dyn. load factor of radial bearings C	stat. load factor of radial bearings C <sub>0</sub>	dyn. load factor of axial bearings C <sub>a</sub>	stat. load factor of axial bearings C <sub>0a</sub>	U-profiles
	mm	mm	mm	mm	mm	mm	mm	mm	mm	mm	mm	kN	kN	kN	kN	
ZTR 060.0350	62.5	30	20	9	30.5	32	7	42	20	8.87	2.95	31	35,5	11	11,5	ZUP 060.0700
ZTR 070.0350	70.1	35	23	10.5	36	37.5	8	48	22	11.4	3.15	45.5	51	13	14	ZUP 070.0700
ZTR 080.0350	77.7	40	23	10.5	36.5	38.5	11.5	54	26	12,87	5	48	56,8	18	18	ZUP 080.0700
ZTR 090.0350	88.4	45	30	10.5	44	46	13	59	26	20,37	5.1	68	72	23	23	ZUP 090.0700
ZTR 110.0350	107.7	60	31	20	55	57.5	14	71	34	24,06	8.9	81	95	31	36	ZUP 110.0700
ZTR 120.0350	123	60	37	14	56	59	16.3	80	40	33,44	9.8	110	132	43	50	ZUP 120.0700
ZTR 150.0350	149	60	45	10.5	58.5	62.5	20	103	50	51,94	17.4	151	192	68	71	ZUP 150.0700

### Simple adjustment of axial bearings:

- Loosen the screws and pull off the outer ring
- Turn the eccentric cam axis
- Check dimension L and adjust it if necessary
- Bolt on the outer ring with its cover
- Lock the screws (Loctite)



### Combinations

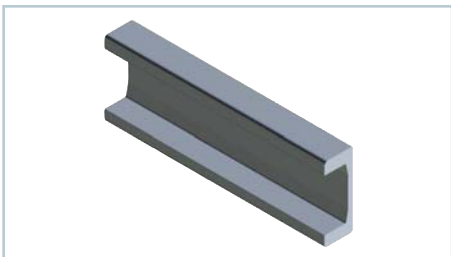

ZUP ---.0700

See page 131 for the appropriate guide profiles in Nb quality

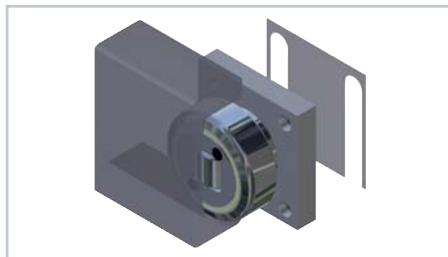

ZBQ ---.1000

See page 134 for square attachment elements with welded-in combination bearings

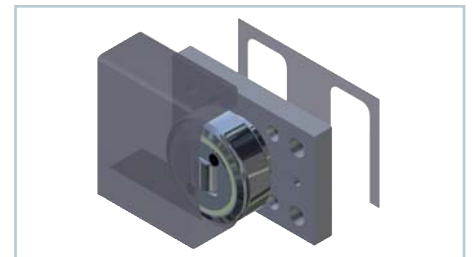

ZBR ---.1100

See page 135 for rectangular attachment elements with welded-in combination bearings

The square attachment element is welded to the respective combination bearing as an assembly.  
Special dimensions on request.

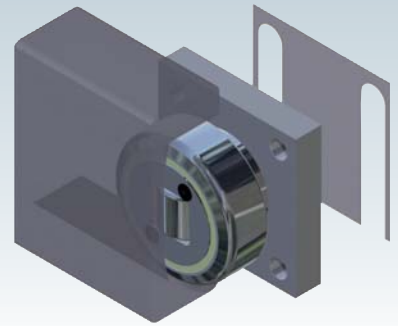

## Attachment element, square

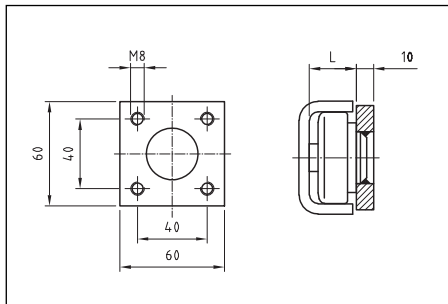

Bearing /profile: ZTR 050.---/ZBQ 1000 Shim: ZBQ 050.---

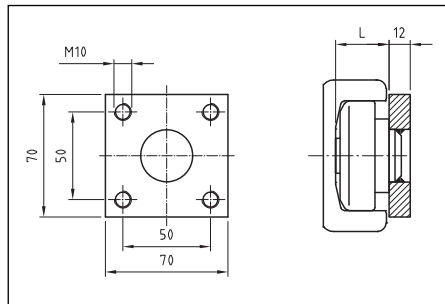

Bearing /profile: ZTR 060.---/ZBQ 1000 Shim: ZBQ 060.---

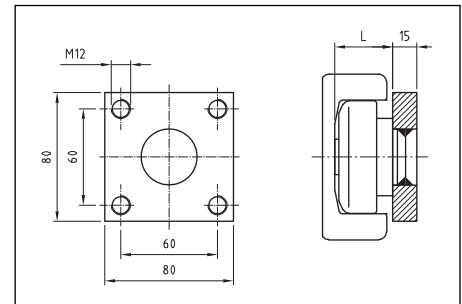

Bearing /profile: ZTR 070.---/ZBQ 1000 Shim: ZBQ 070.---

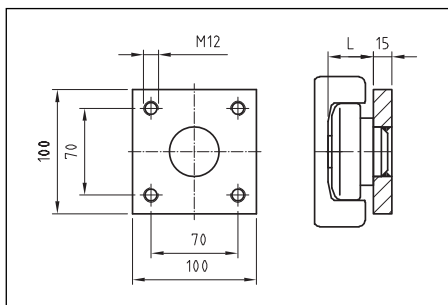

Bearing /profile: ZTR 080.---/ZBQ 1000 Shim: ZBQ 080.---

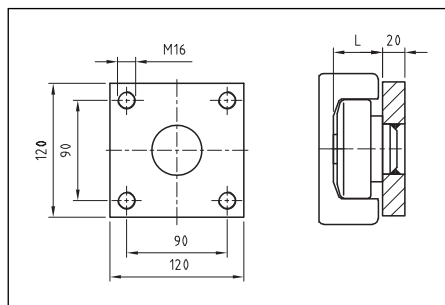

Bearing /profile: ZTR 090.---/ZBQ 1000 Shim: ZBQ 090.---

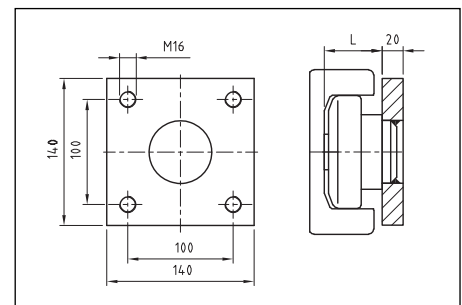

Bearing /profile: ZTR 110.---/ZBQ 1000 Shim: ZBQ 110.---

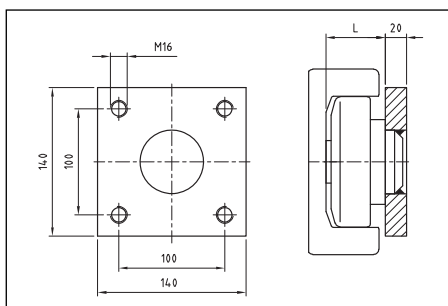

Bearing /profile: ZTR 120.---/ZBQ 1000 Shim: ZBQ 120.---

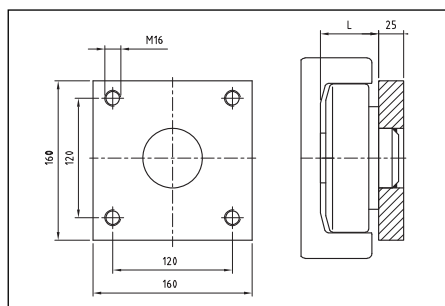

Bearing /profile: ZTR 150.---/ZBQ 1000 Shim: ZBQ 150.---

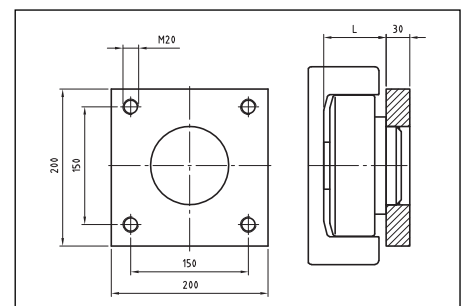

Bearing /profile: ZTR 180.---/ZBQ 1000 Shim: ZBQ 180.---

### Shims:



ZBQ ---.1405 (0.5mm thick)  
ZBQ ---.1410 (1.0 mm thick)



#### Ordering example:

ZTR 070.0200 / ZBQ 1000  
Combination bearings, combined, fixed,  
Ø 70.1 mm welded to attachment  
element 80 mm x 80 mm x 15 mm



The rectangular attachment element is welded to the respective combination bearing as an assembly.  
Special dimensions on request.

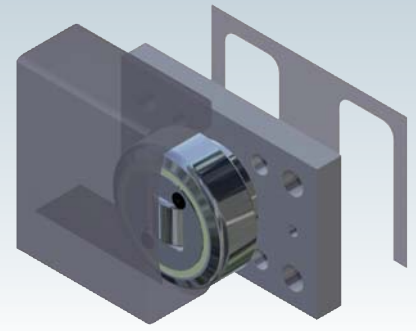

## Attachment element, rectangular

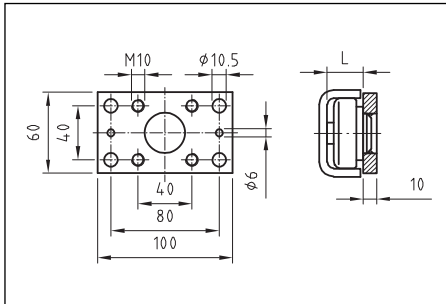

Bearing /profile: ZTR 050.---/ZBR 1100 Shim: ZBR 050.----

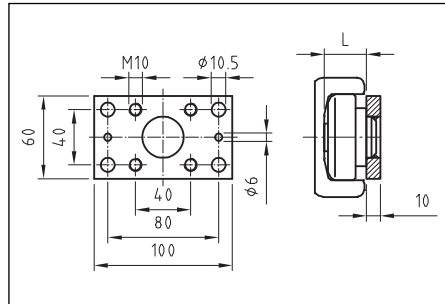

Bearing /profile: ZTR 060.---/ZBR 1100 Shim: ZBR 060.----

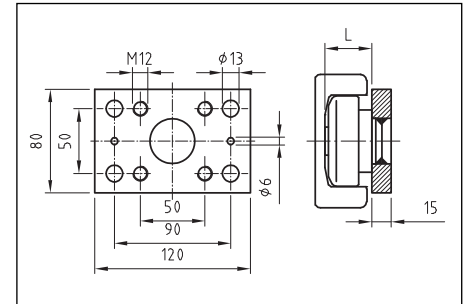

Bearing /profile: ZTR 070.---/ZBR 1100 Shim: ZBR 070.----

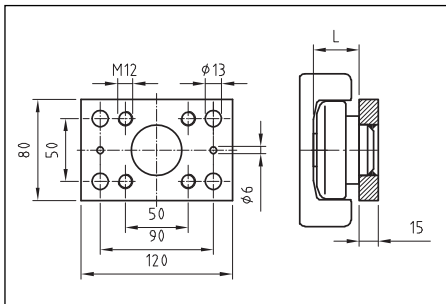

Bearing /profile: ZTR 080.---/ZBR 1100 Shim: ZBR 080.----

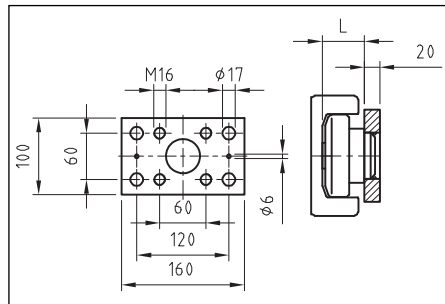

Bearing /profile: ZTR 090.---/ZBR 1100 Shim: ZBR 090.----

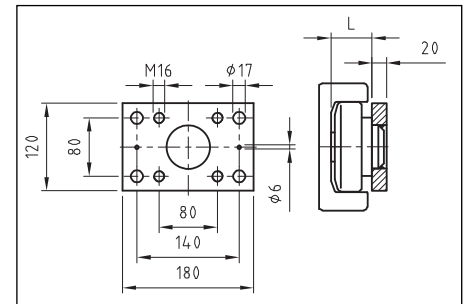

Bearing /profile: ZTR 110.---/ZBR 1100 Shim: ZBR 110.----

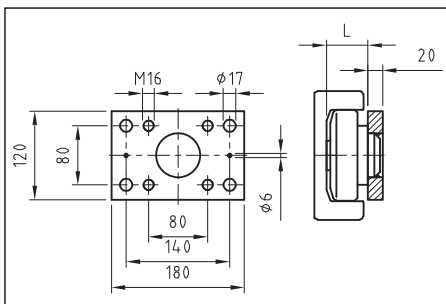

Bearing /profile: ZTR 120.---/ZBR 1100 Shim: ZBR 120.----

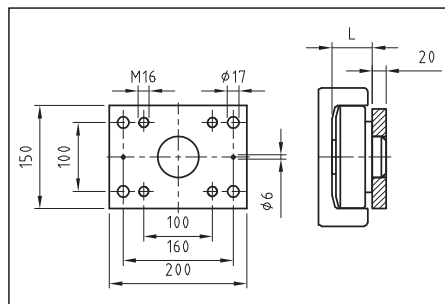

Bearing /profile: ZTR 150.---/ZBR 1100 Shim: ZBR 150.----

### Shims:



ZBR ---.1505 (0.5mm thick)  
ZBR ---.1510 (1.0mm thick)



#### Ordering example:

ZTR 070.0200 / ZBR 1100  
Combination bearings, combined, fixed,  
Ø 70.1 mm welded to attachment  
element 120 mm x 80 mm x 15mm

## Sizes – Bearings and Profiles

Size	Outer Ø	Radial load $F_R$ kN	Axial load $F_A$ kN	U-profiles Nb
50	52.5	5.30	2.00	ZUP 050.0730
60	62.5	8.87	2.95	ZUP 060.0700
70	70.1	11.40	3.15	ZUP 070.0700
80	77.7	12.87	5.00	ZUP 080.0700
90	88.4	20.37	5.10	ZUP 090.0700
110	107.7	24.06	8.90	ZUP 110.0700
120	123	33.44	9.80	ZUP 120.0700
150	149	51.94	17.4	ZUP 150.0700
180	180	76	23	ZUP 180.0700

The load data in this table are calculated based on Hertzian pressure, bearing/profiles.  
At speeds  $n > 10$  rpm, please apply the safety factor.

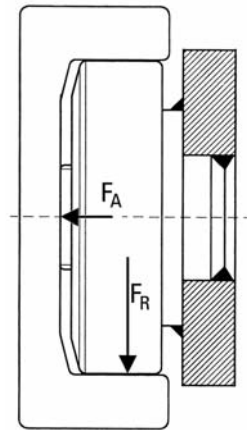

**Caution:**  
In order to avoid indentations or pressure points on the profiles, a surface pressure of 860 N/mm<sup>2</sup> should not be exceeded.

## Technical specifications

- Q Load including own weight (N)
- L Load centre "LSP" (mm)
- RA Bearing spacing (mm)
- A,B Load bearing/profile (N)

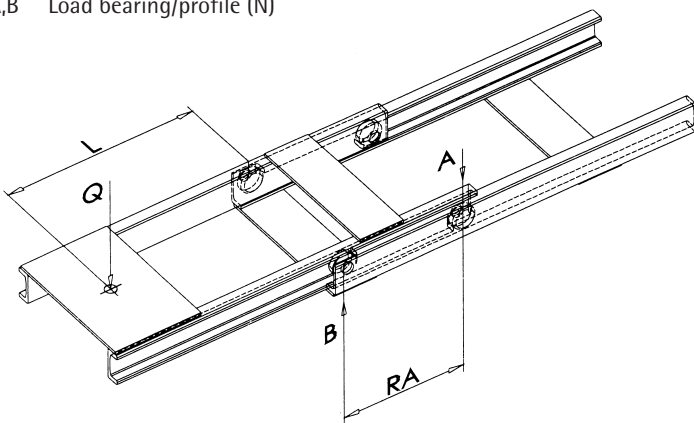

$$A = \frac{Q \times L}{RA \times 2} \text{ (N)}$$

$$B = A + \frac{Q}{2} \text{ (N)}$$

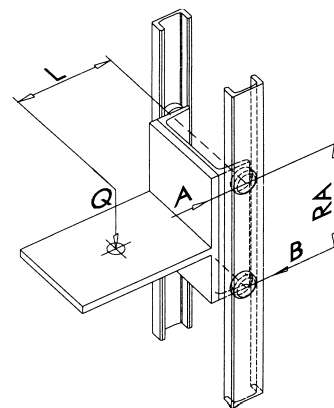

$$A = B = \frac{Q \times L}{RA \times 2} \text{ (N)}$$

## Technical Description

### Guide bearings

#### Tolerances

The cylindrical roller bearings used are made to DIN 620. Tolerance class PN (PO), load factors to ISO 76 and 281/1.

#### Materials

Outer ring: Steel 20CrMnTi, case hardened, surface hardness 62-2 HRC  
 Inner ring: Roller bearing steel UNI 100Cr6, hardness 62-2 HRC  
 Weld-on pin: S355 J2G3, suitable for welding, tolerance band of the pin diameter = 0 / -0.05 mm

#### Seal

ZRS seal  
 Labyrinth / elastomer seal, sealed for life

#### Screws

TORX / screw locking DIN 267-28 polyamide spot coating, eliminates jamming

#### Operating temperature

Generally from -40°C to +120°C, can operate briefly up to +150°C.  
 High-temperature bearings up to +250°C

#### Suitability for relubrication

For extended life the bearings are suitable for relubrication. The delivery holes for relubrication are sealed with M6 threaded plugs. The bearings are supplied without a grease nipple. The bearings should be lubricated at the delivery holes using a grease gun.

#### Lubricant

The standard type of bearings should be lubricated with lithium grease grade 3.

#### Note

The contact faces of the bearings have a convex finish. Bearings with diameter <100 mm should be dismantled before welding is performed.

### Guide profiles

#### Materials

Standard profiles: 18MnNb6  
 Micro-alloy fine grain steel improved with addition of niobium (Nb) and vanadium (V), higher wear resistance, fine-grain structure, highly suitable for welding

#### Lubrication instructions

Before use, the contact surfaces of the guide profiles must first be cleaned and then smeared with grease.  
 Normal commercially-available grease is sufficient.

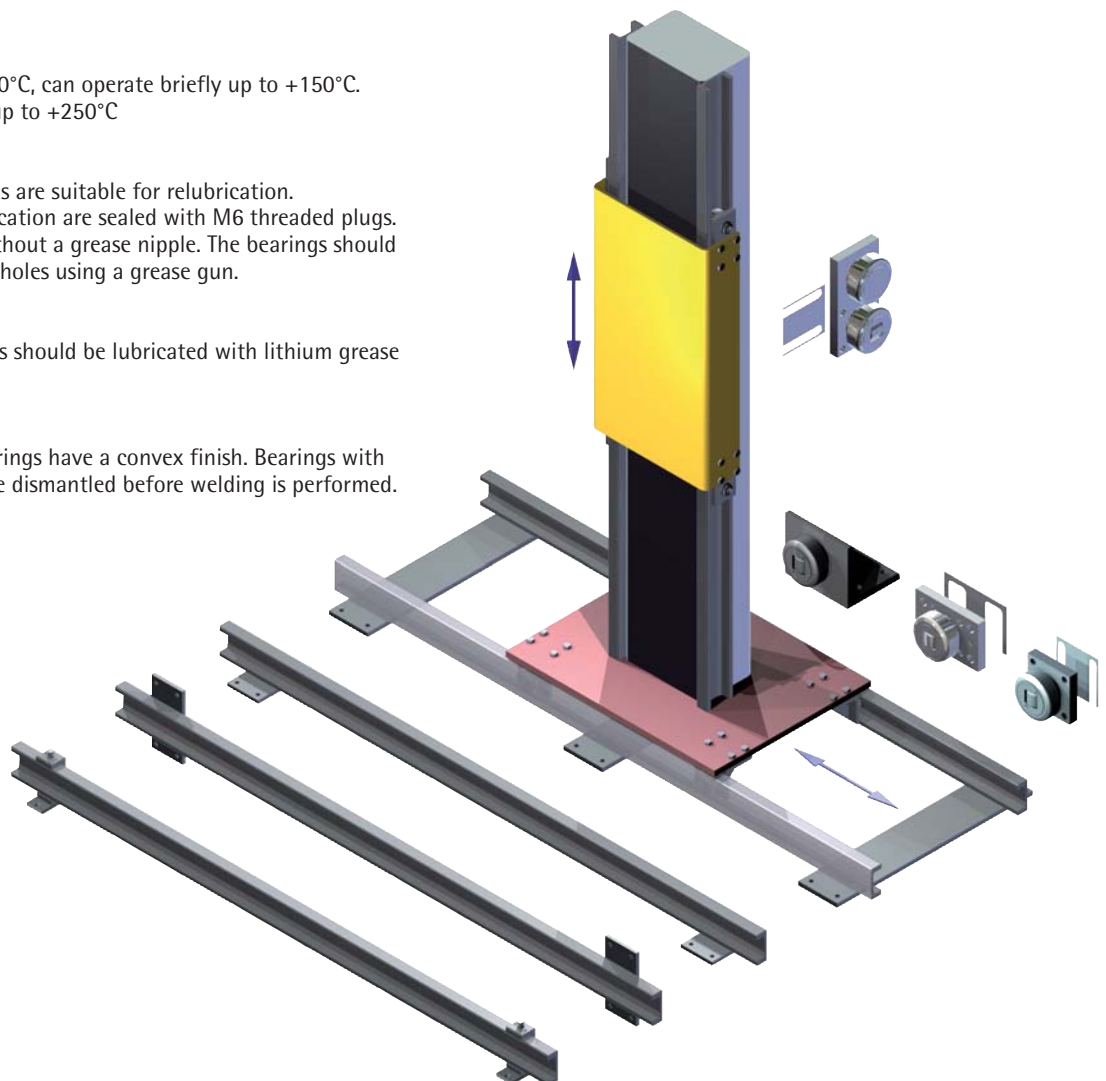



Latensertal "Walser Kamm"



**environment and people**

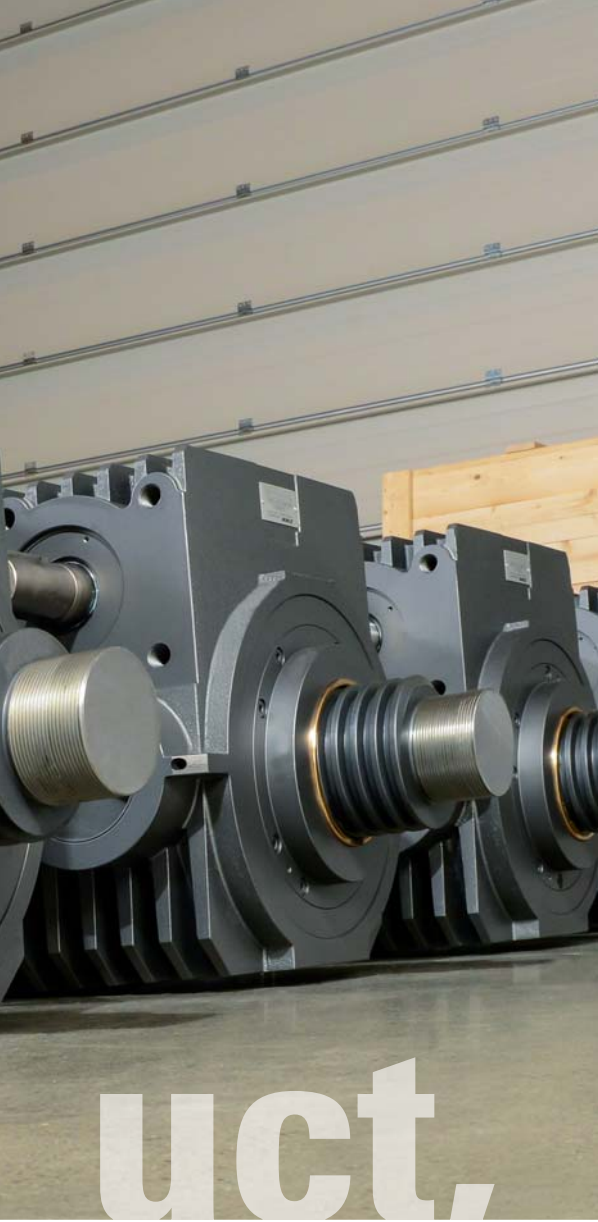

uct,



Subsysteme für die Autom



6

in harmony.



quick and easy  
 → copy  
 → select  
 → fax / e-mail  
 or PDF at [www.zimm.eu](http://www.zimm.eu)

## Checklists - Sheet 1 - Parameters

Company: \_\_\_\_\_ Date: \_\_\_\_\_  
 Address: \_\_\_\_\_ Phone: \_\_\_\_\_  
 Contact: \_\_\_\_\_ Fax: \_\_\_\_\_  
 Dept.: \_\_\_\_\_ E-mail: \_\_\_\_\_

### 1. max. lifting force in kN

- per gearbox \_\_\_\_\_ kN for the entire system \_\_\_\_\_ kN  
 - in tension \_\_\_\_\_ kN in compression \_\_\_\_\_ kN  
 - Load: static \_\_\_\_\_ kN dynamic \_\_\_\_\_ kN

#### Installation axis

vertical  horizontal  pivoting

#### Type of load

smooth  impact loads  vibration

### 2. max. lift/travel \_\_\_\_\_ mm effective working stroke \_\_\_\_\_ mm

For short stroke applications

(eff. working stroke < gearbox height):  regular lubrication stroke practical  not practical

### 3. Lifting speed

type N = 25 mm/s (1.5 m/min)  type L = 6.25 mm/s (0.375 m/min)  \_\_\_\_\_ mm/s

### 4. Duty factor, work cycle, description of cycle

\_\_\_\_\_ strokes per hour \_\_\_\_\_ strokes per day Hours per day  8  16  24

**i** For high duty factors or long strokes, please provide an exact detailed description on page 141, 4a

### 5. Type S "Translating screw" R "Rotating screw" | Z screw jack GSZ screw jack

### 6. Motor Three-phase AC motor With brake Manual release \_\_\_\_\_

### 7. Operating conditions: Dry Humid Dust Chipping \_\_\_\_\_ Guided movement No guides (no dyn. lateral forces)

Ambient temperature: min. \_\_\_\_\_ °C max. \_\_\_\_\_ °C (when <10°C and >40°C)

**i** If possible please provide an exact description or sketch on page 141, 7a

### 8. Standard layouts no.: \_\_\_\_\_ Size: MA1 \_\_\_\_\_ MA2 \_\_\_\_\_ MA3 \_\_\_\_\_ MA4 \_\_\_\_\_ MA5 \_\_\_\_\_

see standard layouts, checklist sheets 5 and 6 (for multi-jack systems)

### 9. Quantity Required: \_\_\_\_\_ Series: \_\_\_\_\_

### 10. Schedule Quotation: \_\_\_\_\_ Delivery: \_\_\_\_\_



# Checklists - Sheet 3 - List of components S

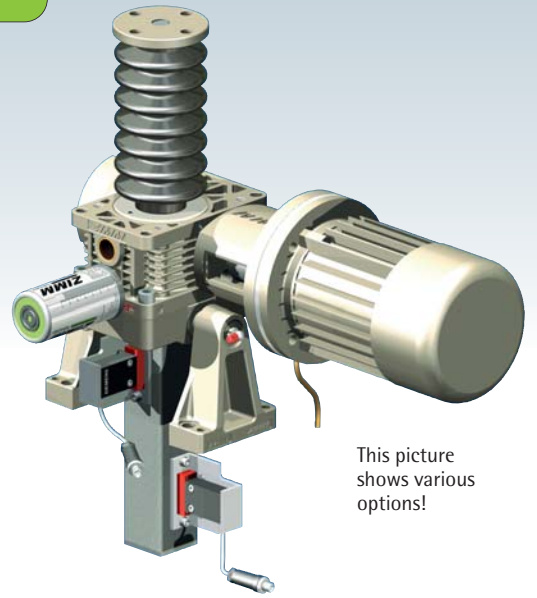

This picture shows various options!

- Type:
- SN (Translating screw, normal)
  - SL (Translating screw, low speed)
- Variant:
- Tr screw
  - SIFA safety nut
  - with SIFA monitoring
  - KGT ball screw

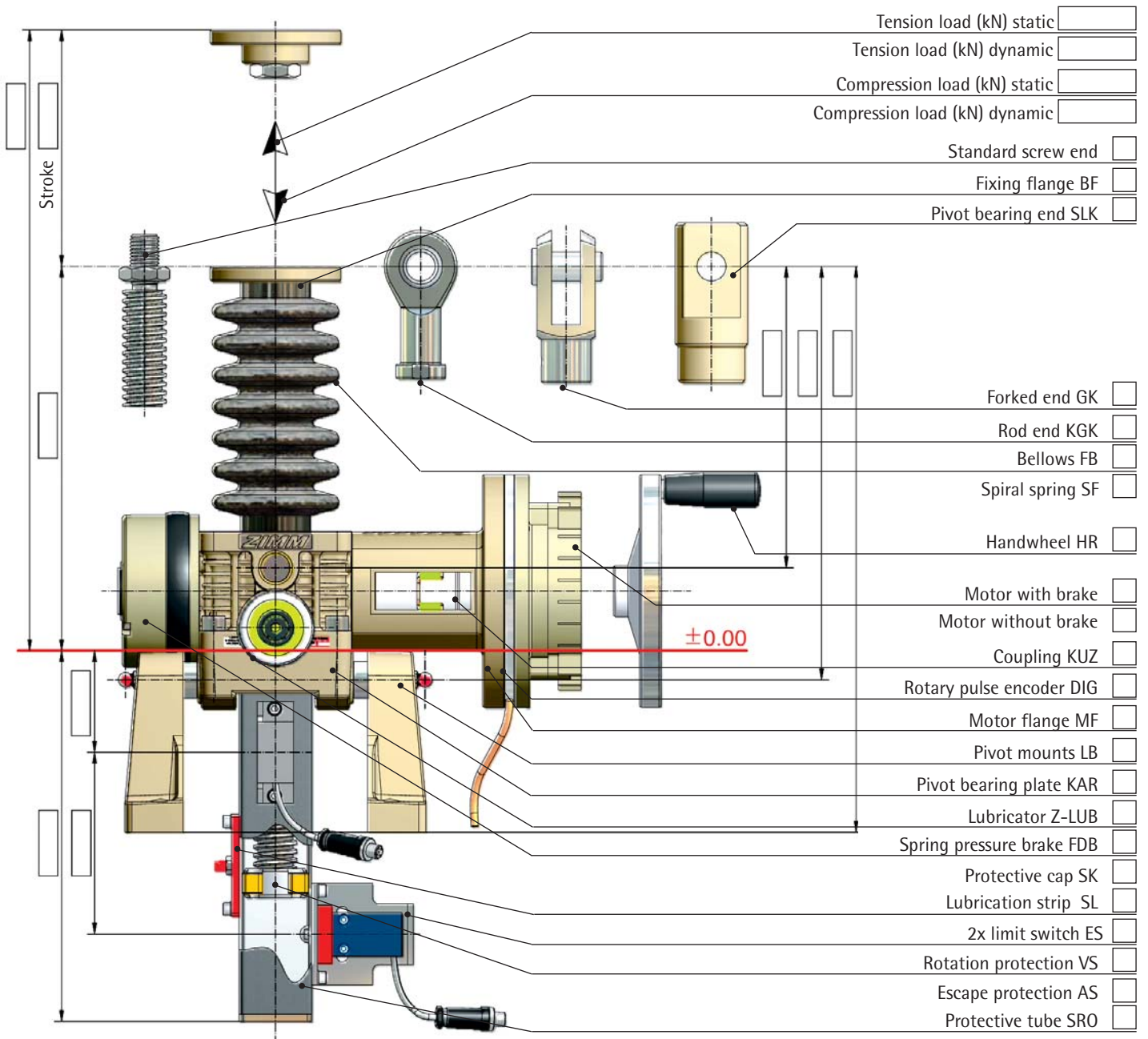



# Checklists - Sheet 4 - List of components R

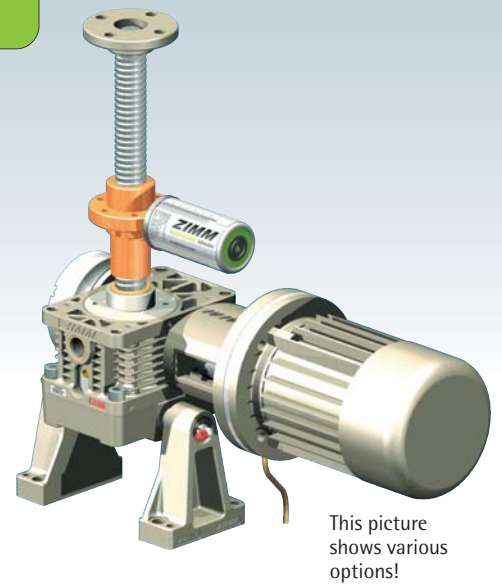

**Type:**

- RN (Rotating screw, normal)
- RL (Rotating screw, low speed)

**Variant:**

- Tr screw
- SIFA safety nut
- with SIFA monitoring

- KGT ball screw

Stroke

±0.00

- Tension load (kN) static
- Tension load (kN) dynamic
- Compression load (kN) static
- Compression load (kN) dynamic
- Opposed bearing plate GLP
- Bellows FB
- Spiral spring cover SF
- Lubricator Z-LUB
- Cardan adapter DMA
- Duplex nut DM
- Tr flange nut FM
- KGT flange nut KGT-F
- Self-aligning nut PM
- Greaseless nut FFDM
- Driving flange TRMFL
- Safety nut SIFA
- Wear monitoring SIFA Control
- Handwheel HR
- Motor with brake
- Motor without brake
- Rotary pulse encoder DIG
- Motor flange MF
- Coupling KUZ
- Pivot mounts LB
- Pivot bearing plate KAR
- Spring pressure brake FDB
- Protective cap SK

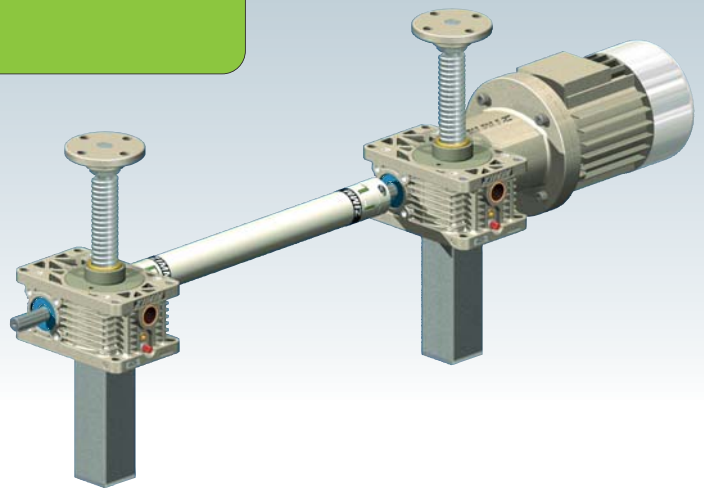

## Checklist - Sheet 5 - System layouts

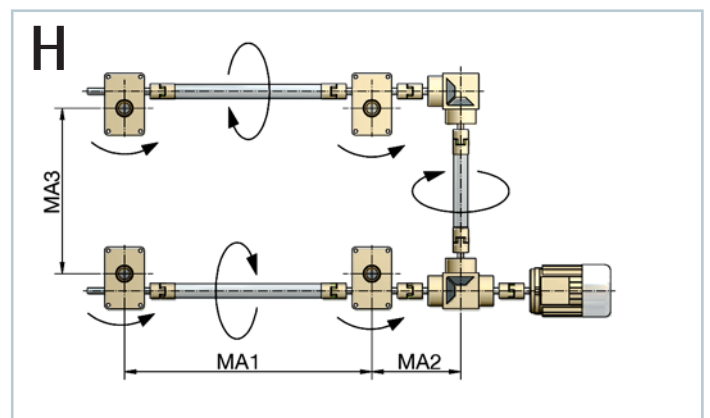
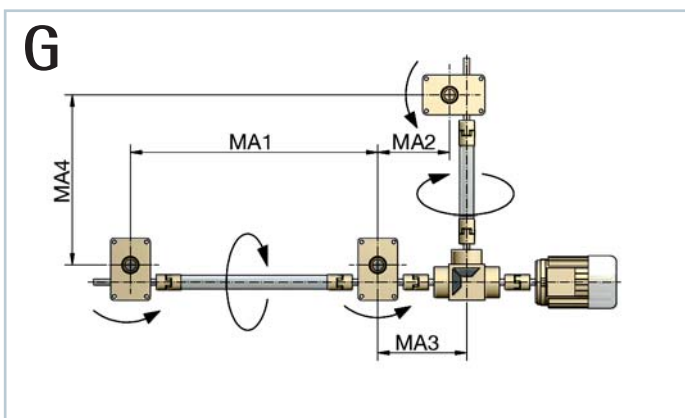
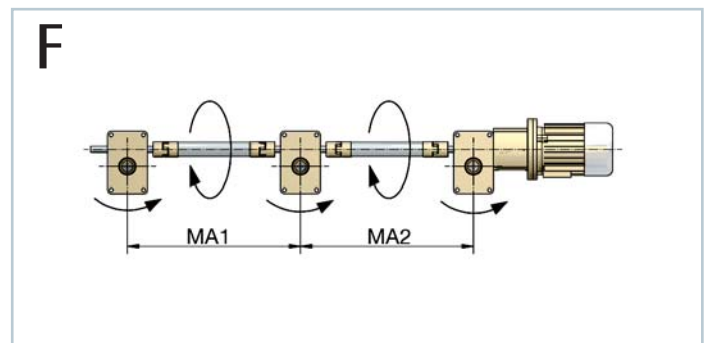
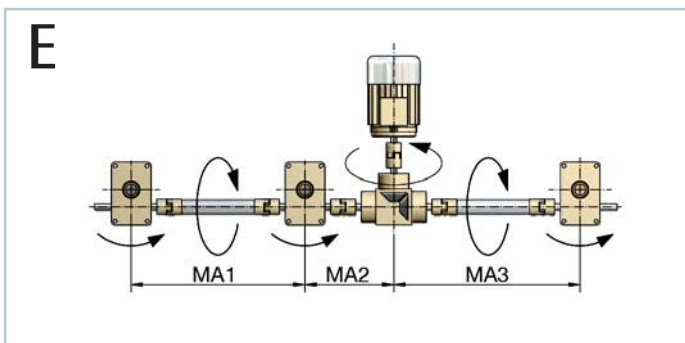
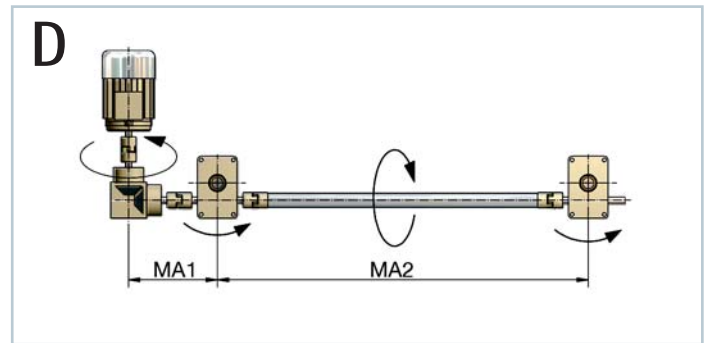
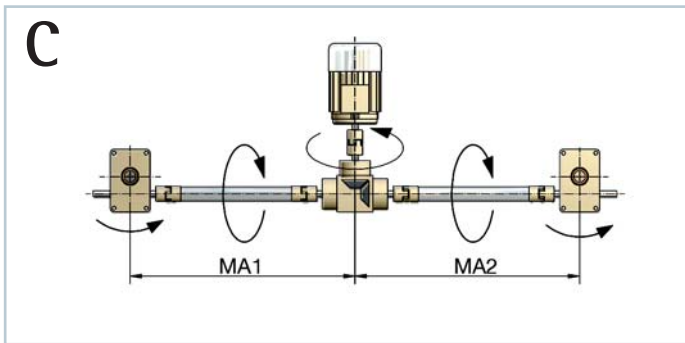
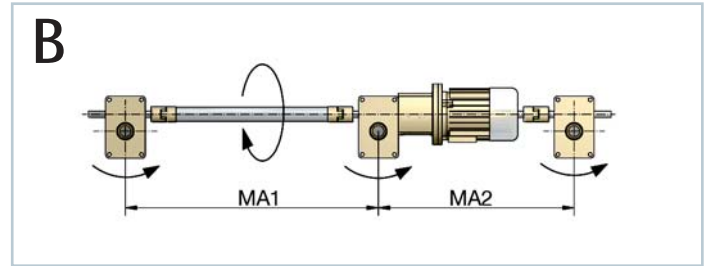
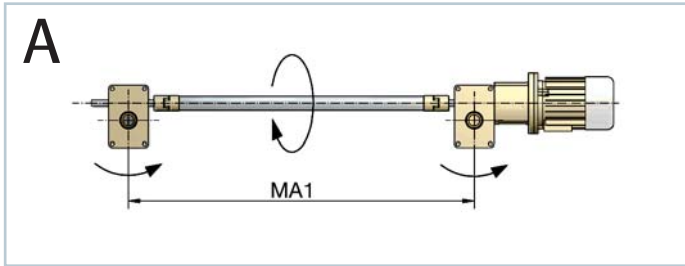

The most common layouts are shown. If your design is different, be sure to check the direction of rotation!

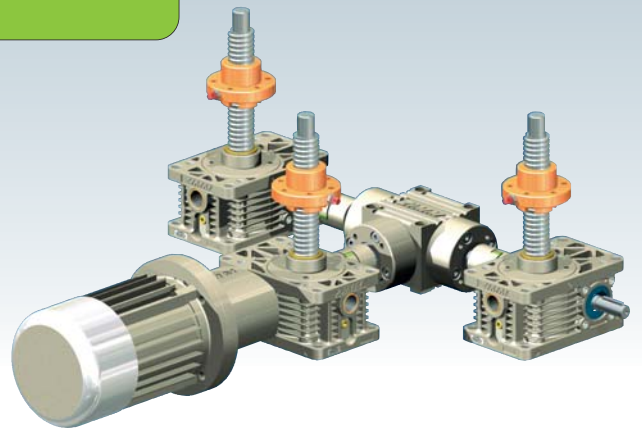

## Checklist - Sheet 6 - System layouts

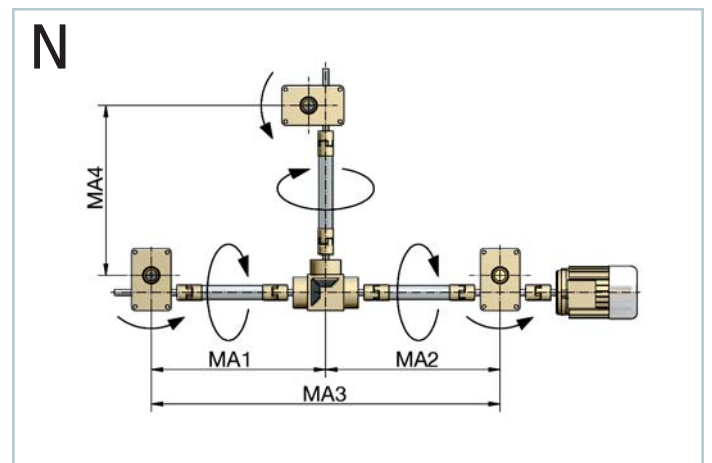
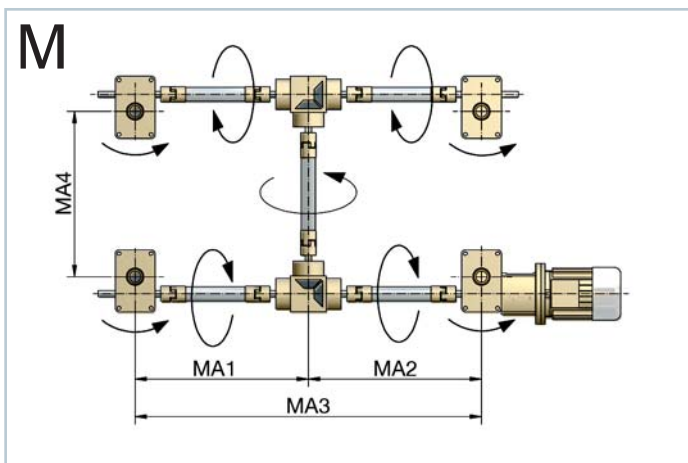
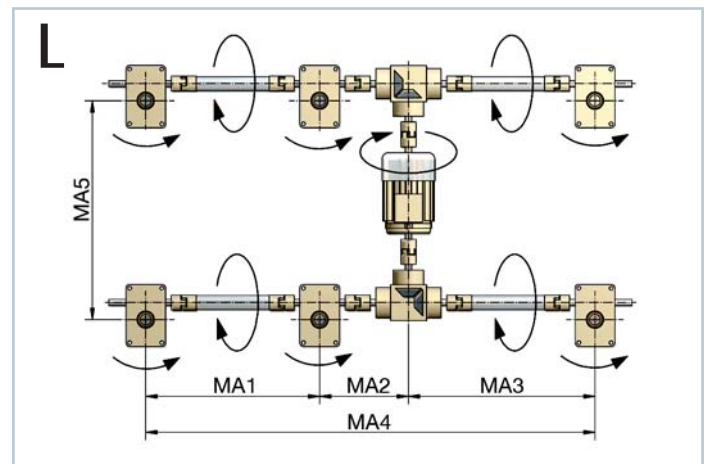
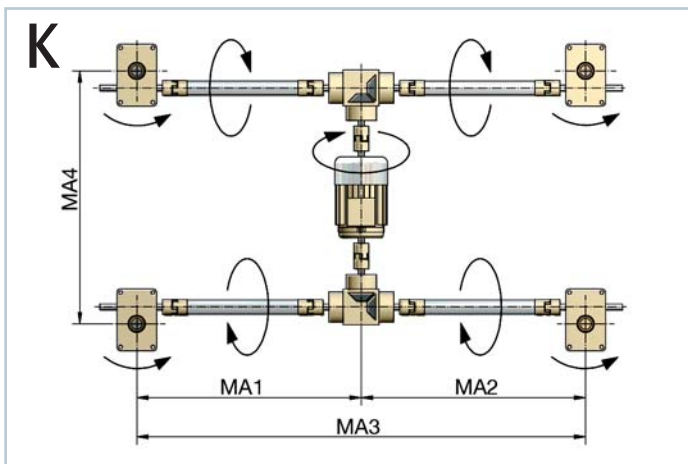
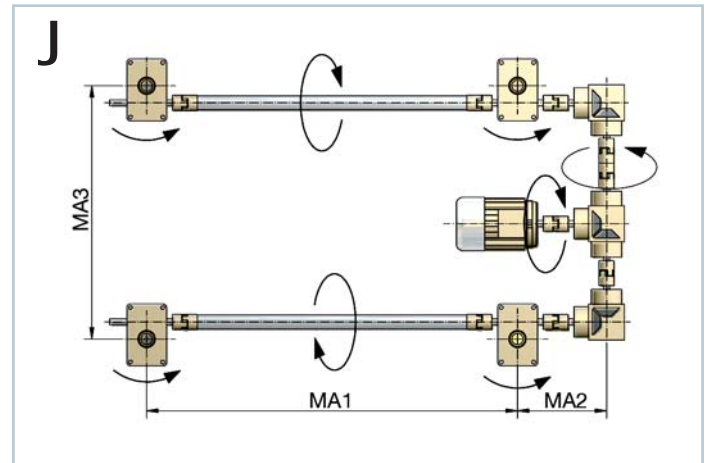
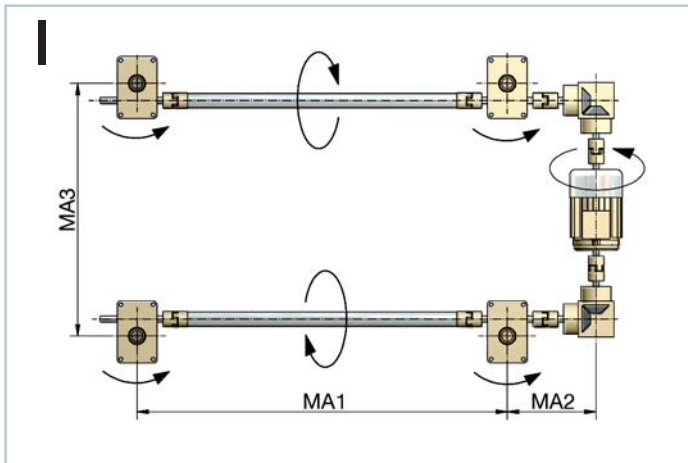

The most common layouts are shown. If your design is different, be sure to check the direction of rotation!

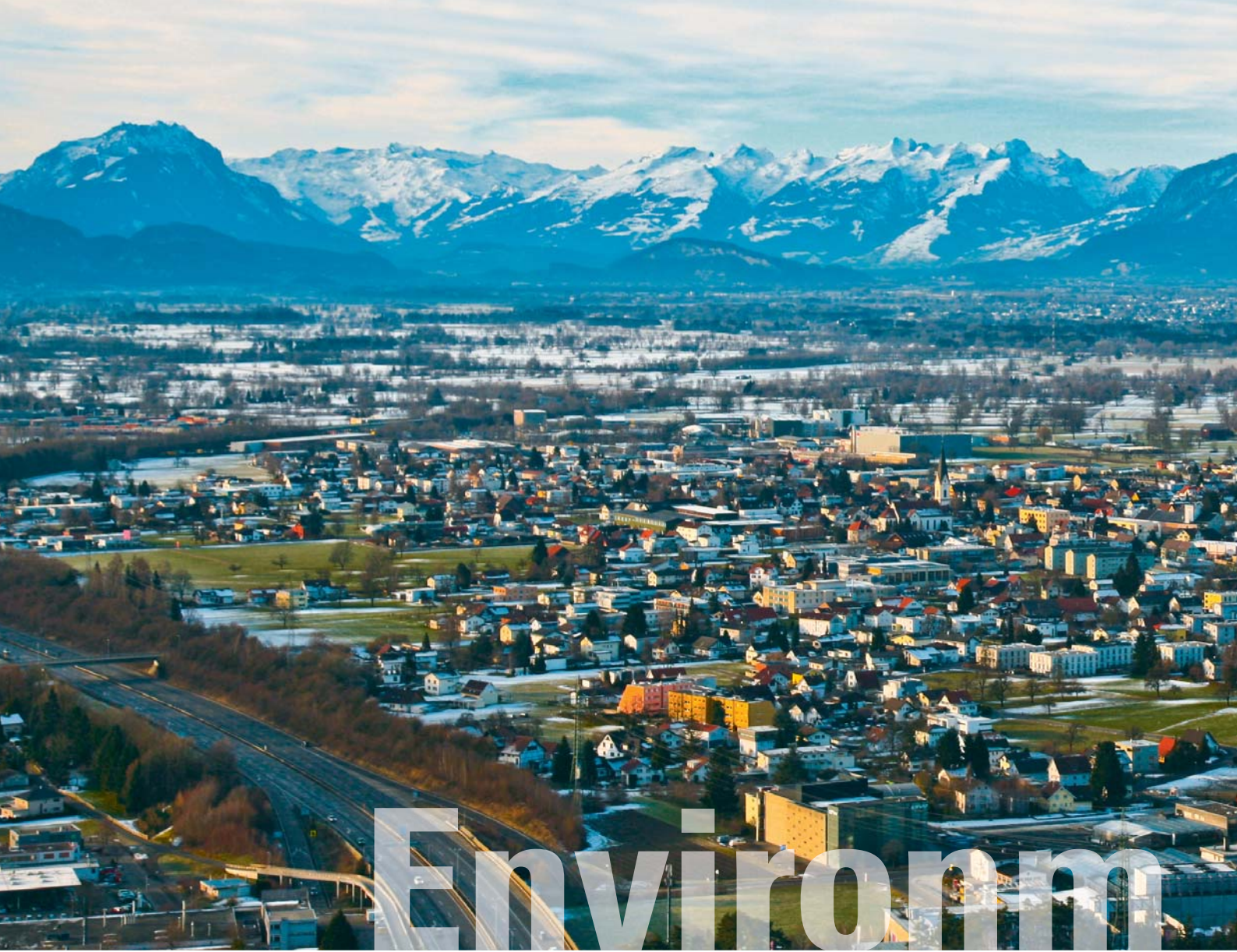

# Environment



**people and product**



in harmony.



## Installation, operation, inspection

Correct installation and commissioning is important for reliable operation of the system. Good maintenance is a precondition for a long service life.

Please therefore study the Instruction Manual which are supplied with each delivery and are also available for downloading from: [www.zimm.eu](http://www.zimm.eu)

## Technical appendix

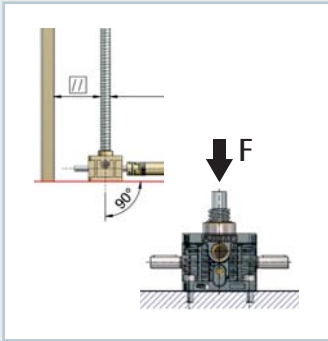

Design advice,  
attachment,  
permissible loads

Page 150

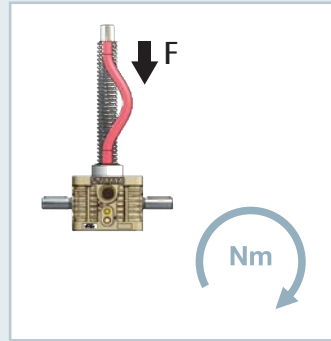

Calculations,  
design,  
tables

Page 160



Operation,  
maintenance

Page 172

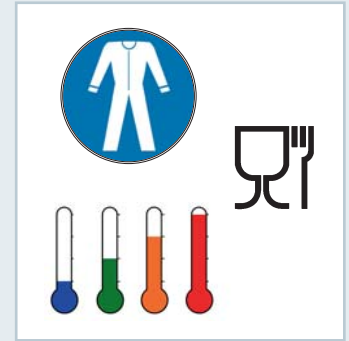

Temperature,  
application range,  
resistant against corrosion

Page 176

## Design advice

### Design and specification

Selection and dimensioning is the customer's responsibility, because we are not familiar with the design criteria such as installation location and type of application. On request we can provide support during selection and specification and make proposals with subassembly drawings and calculations based on your application parameters. You can then examine and approve these drawings and their parts lists.

These then serve as basis for production and preassembly and assist your employees during installation and fitting. We guarantee the quality of the machine elements as described in the catalogue. The gearboxes are designed for industrial use at the loads and duty cycles specified in the catalogue.

If your requirements are not covered by our catalogue descriptions, please contact our project technicians. We generally deliver according to our current Terms of Sales and Delivery (Section 10).

### Lifting speed

Lifting speed  $v = \frac{\text{Screw pitch } P}{\text{Gear ratio } i} \times \text{motor speed } n$

m/min

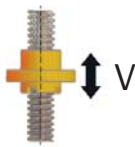

There are several parameters which affect the lifting speed:

#### Faster:

- double-pitch screw (not generally held in stock): This doubles the lifting speed (CAUTION: max. input torque, not self-locking – brake required!)
- increased screw for the R version (next larger size of gearbox): depending on the screw jack size, this will give a somewhat greater pitch / lifting speed
- Ball screw: Various pitches are available (CAUTION: not self-locking– brake required!)

- Frequency converter serves to increase the motor speed to more than 1500 rpm. Please note the maximum gearbox speed.

#### Slower:

- Motors with more poles/lower speed (6, 8, 10 or 12 poles)
- Frequency converter (CAUTION: if the motor is to be operated for extended periods at frequencies less than 25 Hz, adequate cooling must be assured, e.g.: separately driven fan)
- Geared motor (CAUTION: do not exceed the maximum input torque)
- Bevel gearbox with gear reduction (only suitable for certain applications)

### Temperature and duty cycle

Screw jacks are generally not designed for continuous operation.

Refer to the diagram on the gearbox pages (Sections 2 + 3) for the maximum duty cycles (ED).

These are reference values but vary according to usage conditions. In borderline cases, select a larger screw jack or contact our project technicians.

Operating temperatures must not exceed 60°C (gearbox) or 80°C (screw) (higher values on request).

### Rotation protection

On the version S<sub>1</sub>, the translating screw is free running within the gearbox (worm wheel).

The screw must be protected against rotation – otherwise it would rotate due to the friction in the worm wheel. This can be achieved by fixing the screw to an external guidance system or by using our rotation protection (VS) (in the protective tube).

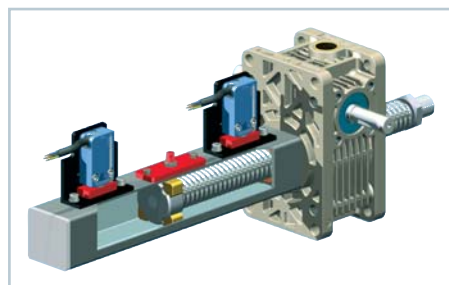

### Parallelism and angular relationships

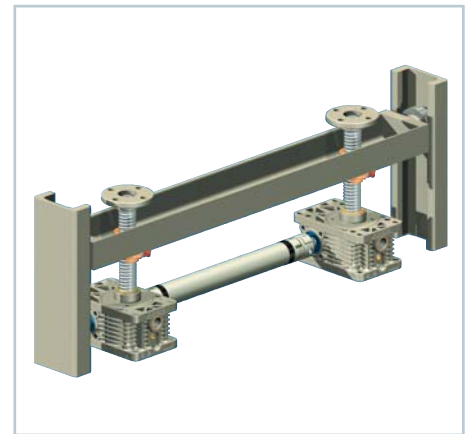

Attention must be paid to the parallelism and correct angular relationships of mounting surfaces, gears, nuts and guides to each other. The same applies for exact alignment of gears, pedestal bearings, connecting shafts and motors to each other.

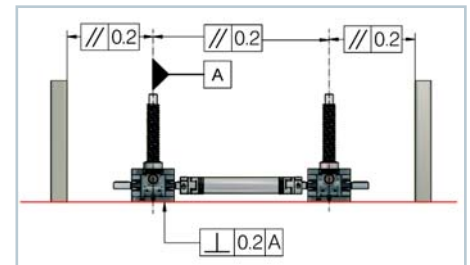

### Guides

Guide bush play in the screw jack gearbox can be between 0.2 mm and 0.6 mm depending on the size. This is just a secondary support and does not replace a guide system specifically provided to cater for lateral forces.

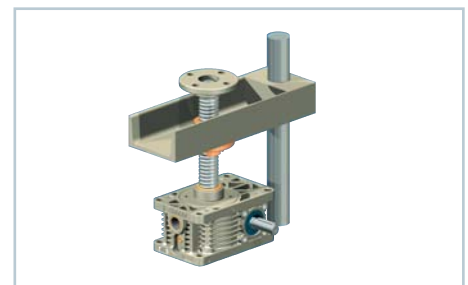



## Design advice

### Safety distance

Safety distances between moving and stationary components must be maintained otherwise there is the risk of the screw jack reaching a blocked position (see Gearbox Dimension Sheets).

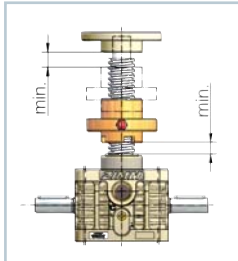

### Accuracy

The repetition accuracy of the gearbox can be up to 0.05 mm when moving to the same position again under the same load conditions.

This requires measures on the drive side, such as a 3-phase AC motor with a brake in conjunction with a frequency converter, a rotary pulse encoder or a servomotor with encoder, etc.

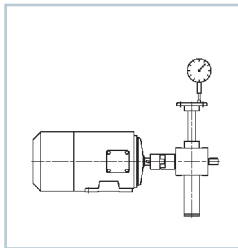

The pitch accuracy for trapezoidal screws is 0.2 mm over a 300 mm screw length, and 0.05 mm for ball screws over a 300 mm screw length.

Under alternating loads, axial play can be up to 0.4 mm on trapezoidal screws and 0.08 mm on ball screws (when new).

### Direction of rotation and movement

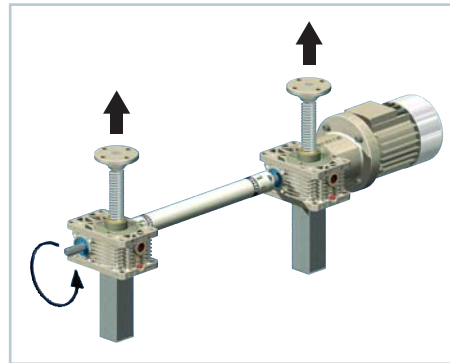

Check the direction of rotation required for the system and record this on the drawing or select one of our standard system layouts (Checklists). With T bevel gearboxes, the direction of rotation can be changed simply by turning the gearbox around.

### Self-locking / overrunning

Screw jacks with a single-pitch trapezoidal screw have a limited self-locking capability which cannot always be relied upon, especially where impact loads or vibrations are present (brake recommended).

The overrun after the motor has been switched off varies depending on the application. To minimize overrun, we recommend using a braked motor or a spring pressure brake FDB. A braked motor is essential for double-pitch screws or ball screws, because these are not self-locking.

### Drive

We recommend the use of a frequency converter to achieve smooth start-up and brake ramps. This minimizes start-up noise and extends the service life of the gearbox.

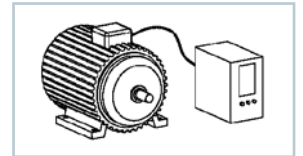

### Trial runs!

Trial runs without load and under load in normal operating conditions are necessary to ensure reliable operation. Do not exceed system duty cycle when loaded. These on-site trial runs are necessary to achieve system alignment and to eliminate any factors which may impair operation.

### Spare parts

To protect against loss of production caused by high duty cycles or high loads, we recommend keeping a set of screw jack spare parts (including screws, accessories and with assembly drawings) at your location or at your customer's location.

### Theatre stage design

We supply lifting equipment which satisfies the current regulations on theatre stage design.

### Land vehicles, aircraft and water craft

Our extended warranty terms generally do not apply to machine elements used in any land vehicles, aircraft and water craft. Special individual terms may be agreed on inquiry.

### Ambient conditions

Please specify any ambient conditions that are outside normal industrial environmental conditions (Checklists - Section 7).



## Design advice

### Lubrication

Adequate lubrication is determine for the service life of a screw jack. Therefore ensure adequate lubrication of screws, gearboxes and rotation protection. The red lubrication strip for rotation protection can be mounted in alternative positions to meet your requirements (please specify).



Please also refer to our lubricator and our Instruction manual.

### Lubrication for short stroke applications

#### S version:

For short stroke applications (stroke < gearbox height), take particular care to ensure lubrication of the trapezoidal screw. The simplest tactic is to specify the screw jack with a longer stroke than the gearbox height, and occasionally perform a lubrication stroke. Otherwise, contact our Engineering Department for a suitable solution.

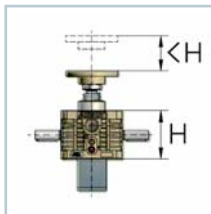

#### R version:

If stroke length < nut height, use a nut with lubrication capability (such as a duplex nut DM).

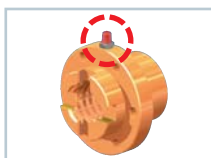

### Instruction manual

Please refer to our Instruction manual during the design phase ([www.zimm.eu](http://www.zimm.eu)).

### Design advice for steel and plant construction:

Hardly any assembly problems arise when screw jacks are used in machine tools, because the relevant surfaces are machined faces.

In steel and plant construction however, frequent geometric errors can occur in welded structures, despite accurate fabrication work. The interaction between different components can also cause alignment issues. Attention must be paid to the following:

#### Parallelism / angular relationships:

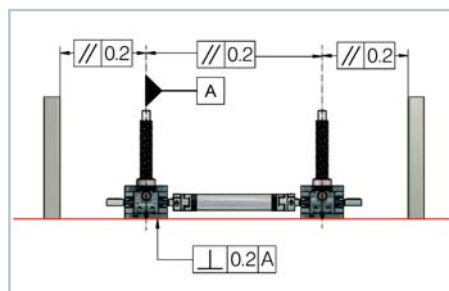

Screws and guides must be parallel to each other, otherwise the equipment can seize up during operation. All mounting surfaces for the gearboxes must be exactly at right angles to the guides, jamming may occur, leading to rapid wear and/or serious damage.

Squeaking noises can also occur on R versions. The mounting surfaces for the nuts must also be at right angles.

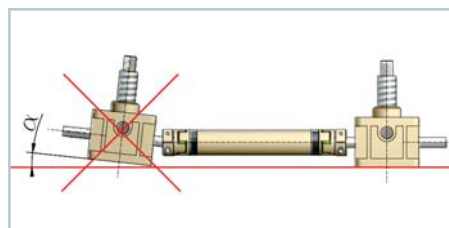

ZIMM has developed the self-aligning nut PM (see Section 4) to save time and costs here.

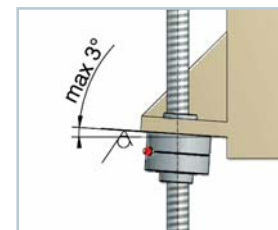
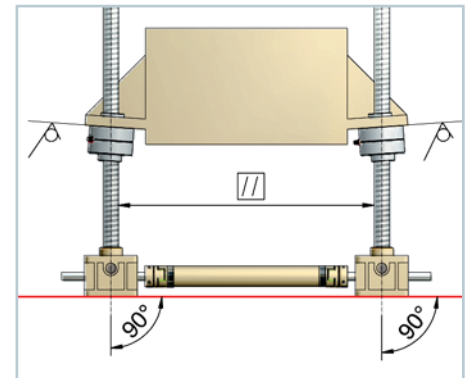



Additional features where alignment may be a problem are the integrated pivot bushings in the gearbox or the pivot bearing plate KAR (see Section 4).

#### For steel and plant construction:

We supply standard heavy-duty linear guides including bearings. Their stability, long service life, avoidance of geometric errors and ability to accept lateral side forces are decisive arguments for using such guides.

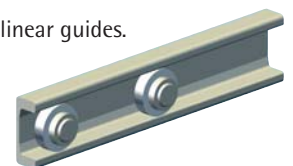
See Section 6 for linear guides.



 Printing errors, dimensional mistakes etc. and also technical changes and improvements are excepted. Drawings are valid only when they have been checked and approved by both partners in accordance with the order acknowledgement.

# Specification of a screw jack or lifting system – procedure

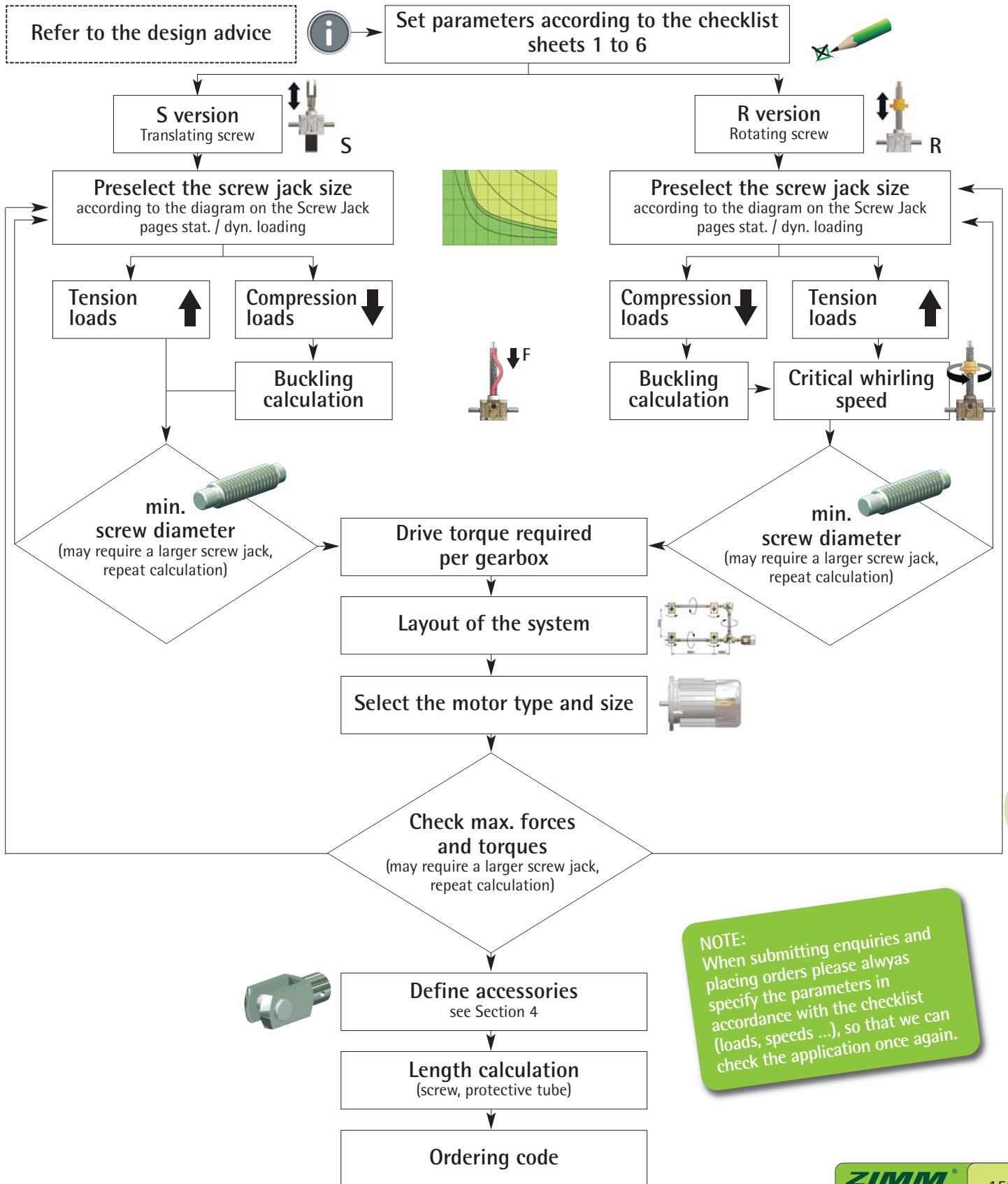

**NOTE:**  
When submitting enquiries and placing orders please always specify the parameters in accordance with the checklist (loads, speeds ...), so that we can check the application once again.

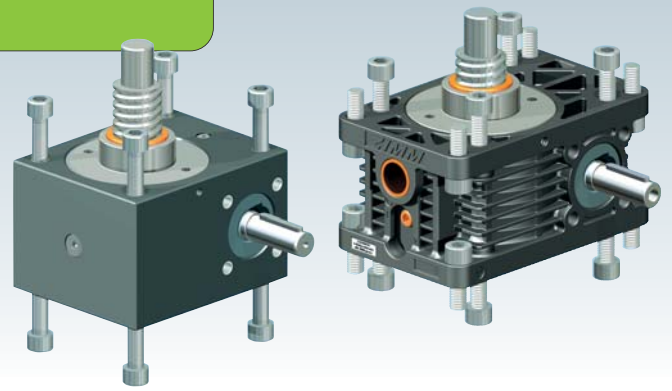

## Fixing - fixed

From above:



Through screws  
(for the Z series)

The great advantage of the Z series is that it can easily be attached from above.

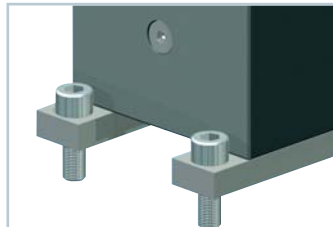

Fixing strips  
(for the GSZ series)

Top mounting fixing strips BFL are required for attaching GSZ gearboxes from above.

Through the mounting plate:

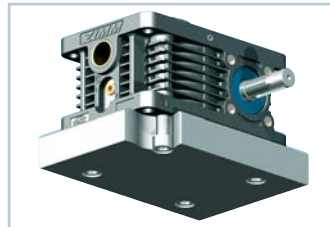

Blind tapped holes  
(Z and GSZ series):

Z and GSZ series can be attached from underneath using the blind tapped holes in the gearbox.

GSZ: all sizes

Z: Z-5 to Z-25 (holes the same size as the previous MSZ gearboxes)

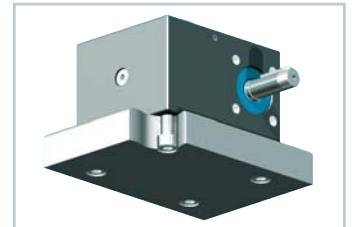

## Fixing - pivoting

Duplex nut adapter DMA

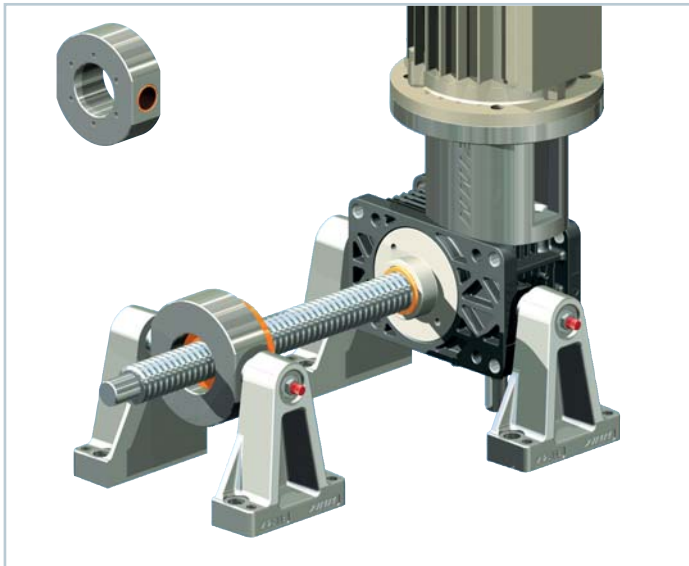

The duplex nut adapter DMA is simply bolted to the duplex nut DM. The pivot can be made with the pivot mounts LB or a mounting designed by the customer.

Pivoting support tube STRO

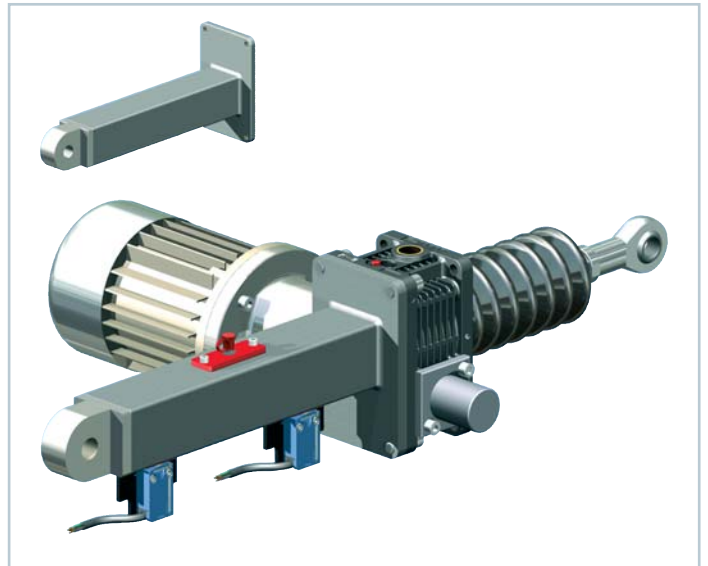

The pivoting support tube STRO has the advantage that the pivot points are entirely external. The disadvantage is that the gearbox and motor weights are in the centre. The manufacture is always customer-specific.

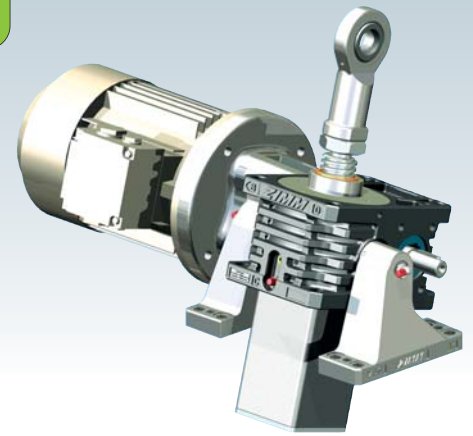

## Fixing - pivoting

### Z-5 to Z-25

#### Integrated pivot bearing

Simple and economical design: Pivot bushes are incorporated in the gearbox housing.

#### With pivot bearing plate KAR

For large motors, long strokes and high load cycles, the variant with the pivot bearing plate KAR is preferable, because the weight of the motor is then taken by the bearing points and does not affect the screw.

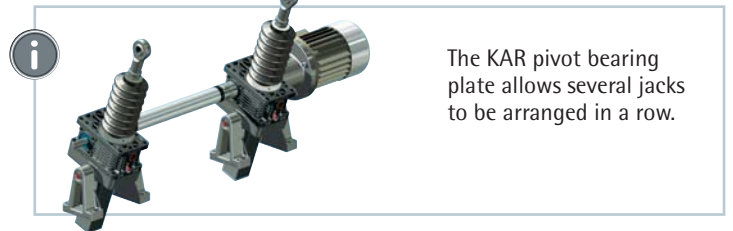
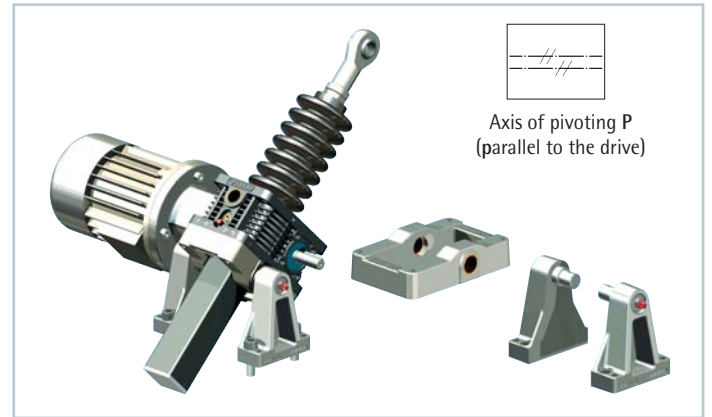
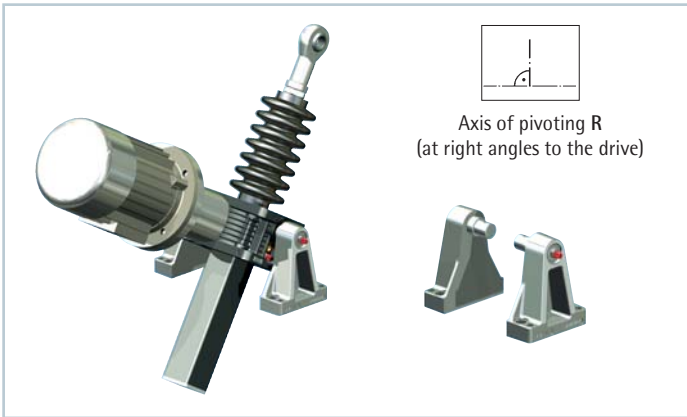

### Z-35 to Z-1000

#### Integrated pivot bearing

Simple and economical design: Pivot bushes are incorporated in the gearbox housing.

### GSZ-2 to GSZ-100

#### With pivot bearing plate KAR

For GSZ gearboxes, a pivot bearing plate can be mounted on face E (above) or F (underneath). In each case there are 4 holes available for the pivot plate P or R.

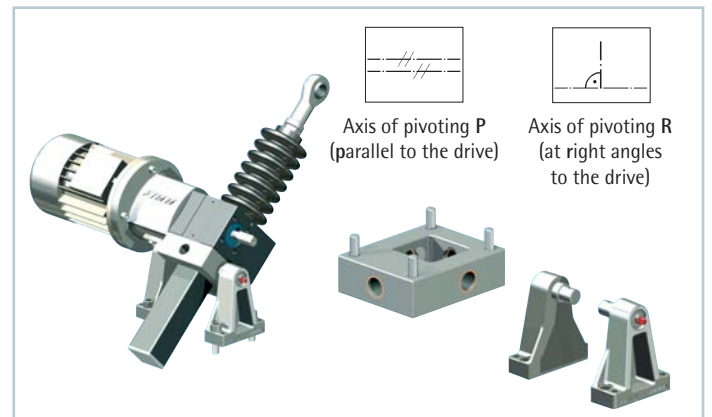
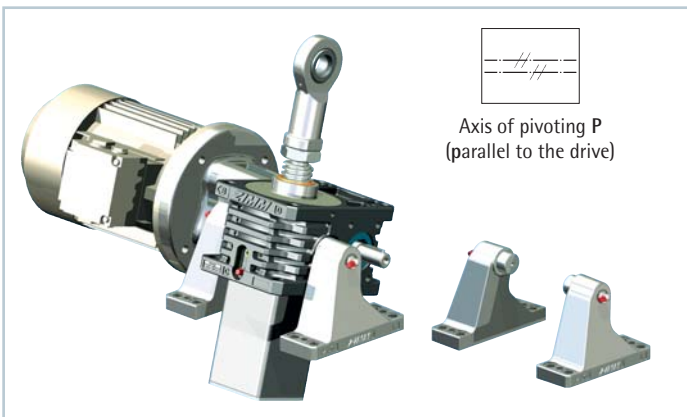

Pivot bearing plate KAR on request

## Permissible loads - fixed

The screw jacks themselves are specified for full static nominal load under tension and compression. The permissible load depends on the type of fastening.

### Compressive load

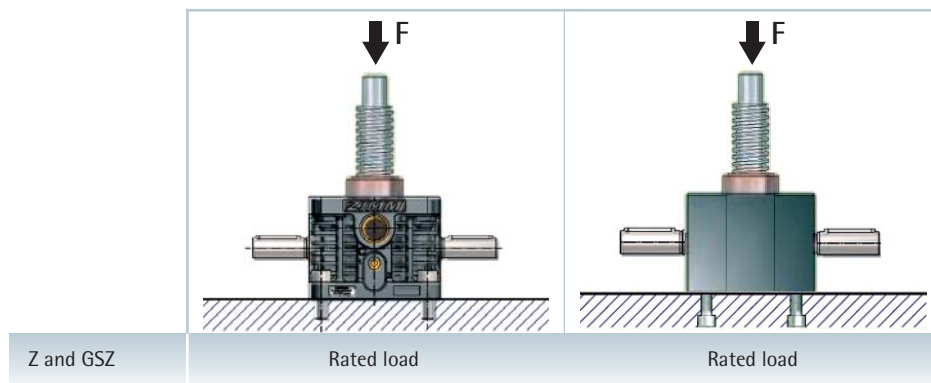

**Full rated load**  
The gearbox can accept the full static rated load.

### Mounting plate with tensile load

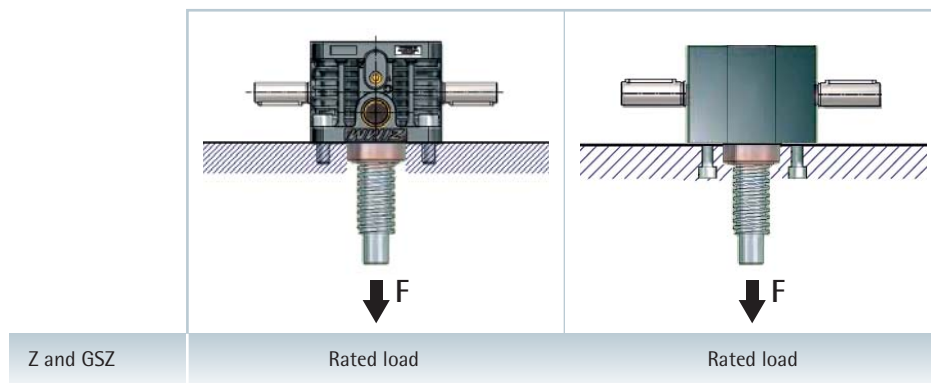

**Full rated load**  
The gearbox can accept the full static rated load.

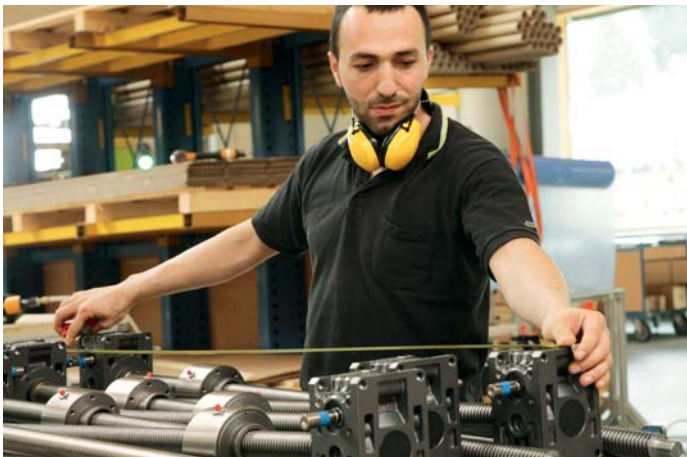

## Permissible loads - fixed

### Tensile load on the fixing screws (blind tapped holes) - Z and GSZ

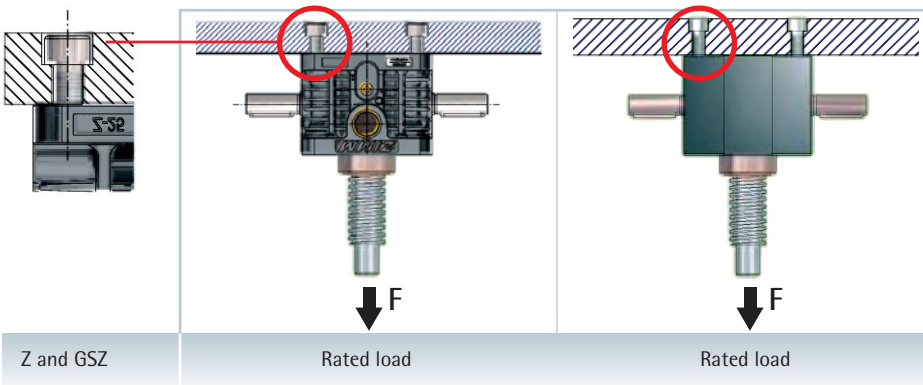

**Full rated load**  
 Providing the screw-in depth is maintained and the screws are tightened to the full tightening torque, the full rated load is permissible.

Gearbox	Thread*	Screw-in depth [mm]	Tightening torque [Nm]
GSZ-2	M6	8 to 10	8
GSZ-5, Z-5	M8	10 to 11.5	19
GSZ-10, Z-10	M8	10 to 15	17
GSZ-25, Z-25	M10	12 to 15	27
GSZ-50	M12	12 to 17	38
GSZ-100	M16	16 to 20	82

### Tensile load on the fixing screws (through holes in the housing)

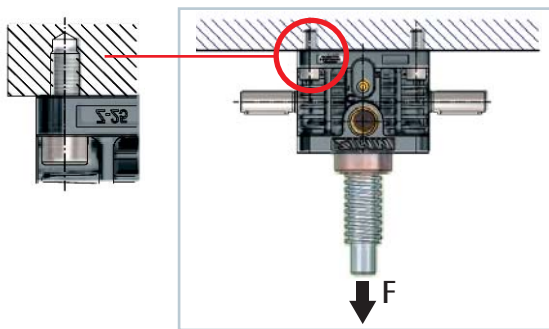

**Reduced load**  
 If the fixing screws on the housing are loaded in tension, only reduced loads are permissible.

Gearbox	Permissible load	with fixing screws*
Z-5	2.5 kN	-
Z-10	3.5 kN	-
Z-25	10.0 kN	-
Z-35	29.8 kN	-
Z-50	27.5 kN	-
Z-100	27.0 kN	-
Z-150	56.5 kN	-
Z-250	70.0 kN	Rated load 250 kN
Z-350	180.0 kN	Rated load 350 kN
Z-500	110.0 kN	Rated load 500 kN
Z-750	210.0 kN	Rated load 750 kN
Z-1000	on request	Rated load 1000 kN

\*Through holes and blind tapped holes, dimension sheet and screw-in depth on request.

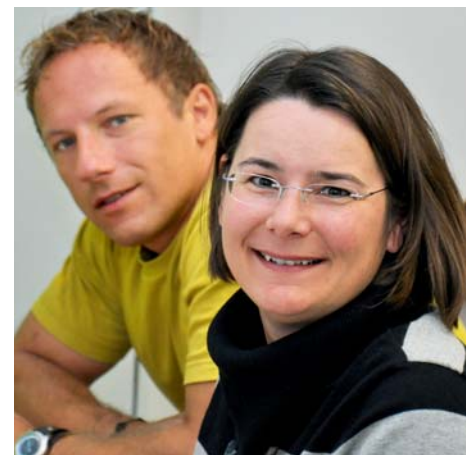

## Permissible loads - pivoting

When dimensioning, include all the parts you will use

### Z-5 to Z-25 - Pivot bearing in the housing

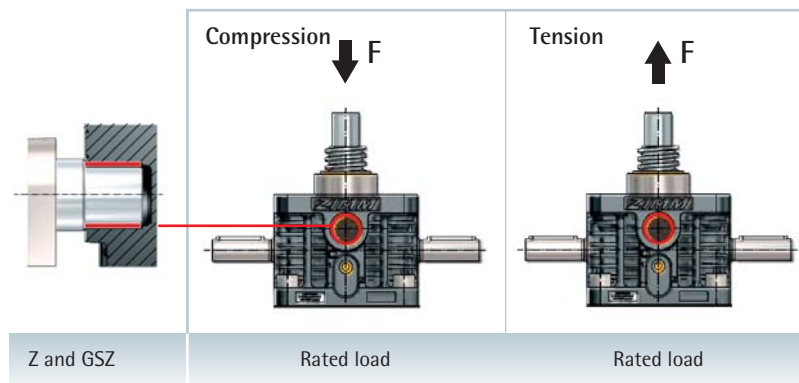

### Z-5 to Z-25 - Pivot mounts LB

	Compression ↓ F	Tension ↑ F	90° ← F → F	45° ↖ F ↗ F
Z-5 (Z-5/10-LB)	Rated load 5 kN	Rated load 5 kN	Rated load 5 kN	Rated load 5 kN
Z-10 (Z-5/10-LB)	Rated load 10 kN	Rated load 10 kN	7 kN	6.5 kN
Z-25 (Z-25-LB)	19.5 kN	17.5 kN	10 kN	9.5 kN

### Z-5 to Z-25 - Pivot bearing plate KAR

	Compression ↓ F	Tension ↑ F	Compression ↓ F	Tension ↑ F
Z-5-KAR	Rated load 5 kN	2.5 kN	2.5 kN	Rated load 5 kN
Z-10-KAR	Rated load 10 kN	3.5 kN	3.5 kN	Rated load 10 kN
Z-25-KAR	Rated load 25 kN	10 kN	10 kN	Rated load 25 kN

#### Direction of loading

The direction of loading should be selected so that the gearbox is pressed against the pivot bearing plate. When the load is in the opposite direction, reduced load values apply.



## Permissible loads - pivoting

The gearbox housing is relevant to the specification.  
The pivot mounts Z-35 to Z-1000 are specified for the full rated load in both directions.

### Z-35 to Z-1000 – Pivot bearing in the housing

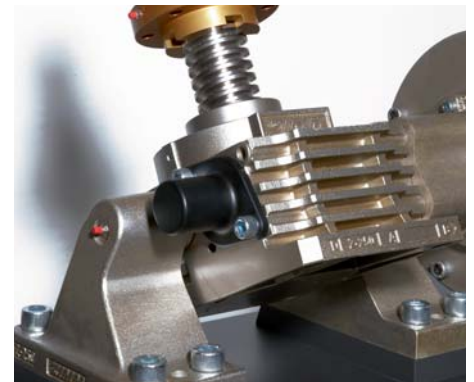
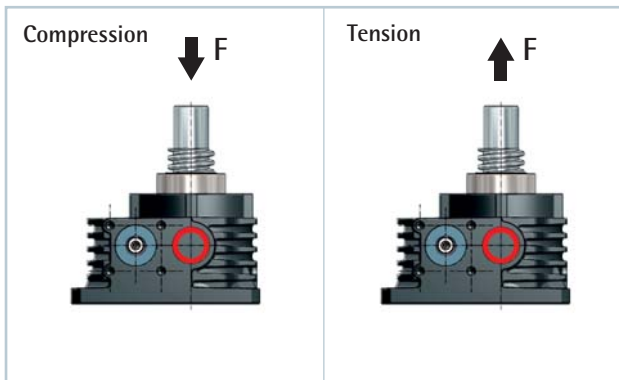

Z-35	Rated load	35 kN	Rated load	35 kN
Z-50	Rated load	50 kN	Rated load	50 kN
Z-100	Rated load	100 kN	Rated load	100 kN
Z-150	Rated load	150 kN	Rated load	150 kN
Z-250		177 kN	Rated load	250 kN
Z-350		250 kN		260 kN
Z-500		280 kN		310 kN
Z-750		on request		on request
Z-1000		on request		on request

### Z-35 to Z-1000 – Pivot mount LB

From Z-500 the gearbox is mounted the opposite way round, since the footplate is broader than the rest of the housing:

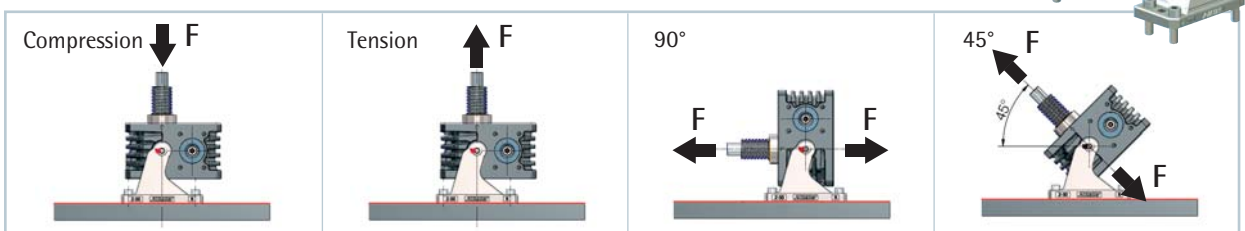

Z-35 to Z-1000	Rated load	Rated load	Rated load	Rated load
----------------	------------	------------	------------	------------

### Duplex nut adapter DMA

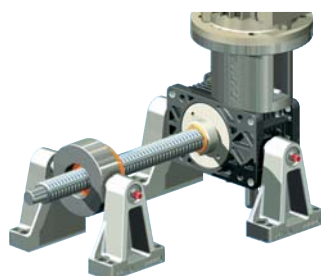
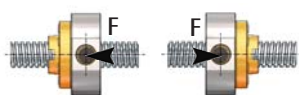

**Main direction of loading**  
Select the main direction of loading so that tensile loads on the nut are avoided.

### Support tube STRO



In compression the full rated load permissible. In tension the support tube should be subjected only to limited loads.

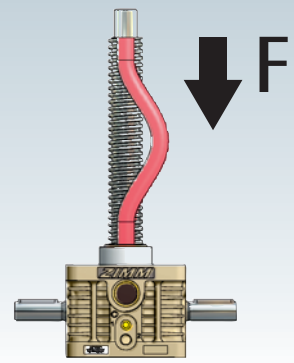

## Critical buckling force of the screw

### Explanatory notes:

$I$  = 2nd moment of area expressed in  $\text{mm}^4$   
 $F$  = Max. load/gearbox in N  
 $L$  = Free screw length in mm  
 $E$  = Modulus of elasticity for steel ( $210,000 \text{ N/mm}^2$ )  
 $v$  = Safety factor (normally 3)  
 $d$  = Minimum core diameter of the screw

### Example:

$F = 45,000 \text{ N/gearbox}$   
 $L = 1320 \text{ mm}$   
 $v = 3$

### Euler 1

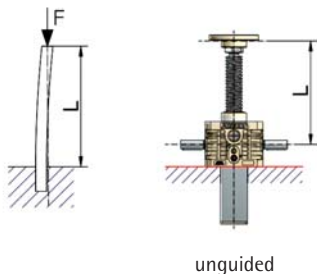

### Formula:

$$I = \frac{F \times v \times (L \times 2)^2}{\pi^2 \times E} \quad \text{then} \quad d = \sqrt[4]{\frac{I \times 64}{\pi}}$$

### Example:

$$I = \frac{45,000 \text{ N} \times 3 \times (1,320 \text{ mm} \times 2)^2}{\pi^2 \times 210,000 \text{ N/mm}^2} = \frac{9.0896^{11} \text{ mm}^4}{2,072,616.924} = 453,965.22 \text{ mm}^4$$

$$d = \sqrt[4]{\frac{453,965.22 \text{ mm}^4 \times 64}{\pi}} = 55.15 \text{ mm minimum core diameter}$$

= Z-250 (screw core  $\varnothing = 59.6 \text{ mm}$ )

### Euler 2

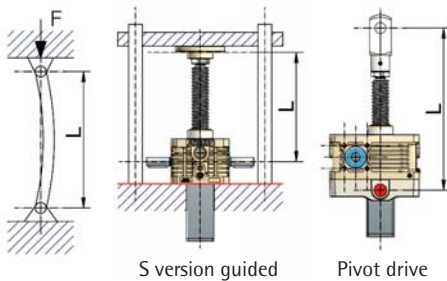

### Formula:

$$I = \frac{F \times v \times L^2}{\pi^2 \times E} \quad \text{then} \quad d = \sqrt[4]{\frac{I \times 64}{\pi}}$$

### Example:

$$I = \frac{45,000 \text{ N} \times 3 \times (1,320 \text{ mm})^2}{\pi^2 \times 210,000 \text{ N/mm}^2} = \frac{2.35224^{11} \text{ mm}^4}{2,072,616.924} = 113,491.305 \text{ mm}^4$$

$$d = \sqrt[4]{\frac{113,491.305 \text{ mm}^4 \times 64}{\pi}} = 38.99 \text{ mm minimum core diameter}$$

= Z-100 (screw core  $\varnothing = 43.6 \text{ mm}$ )

### Euler 3

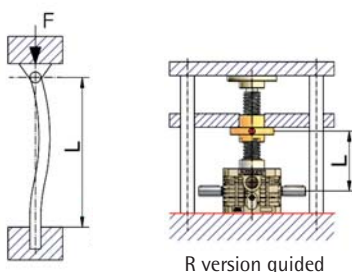

### Formula:

$$I = \frac{F \times v \times (L \times 0.7)^2}{\pi^2 \times E} \quad \text{then} \quad d = \sqrt[4]{\frac{I \times 64}{\pi}}$$

### Example:

$$I = \frac{45,000 \text{ N} \times 3 \times (1,320 \text{ mm} \times 0.7)^2}{\pi^2 \times 210,000 \text{ N/mm}^2} = \frac{1.15259^{12} \text{ mm}^4}{2,072,616.924} = 55,610.7396 \text{ mm}^4$$

$$d = \sqrt[4]{\frac{55,610.739 \text{ mm}^4 \times 64}{\pi}} = 32.62 \text{ mm minimum core diameter}$$

= Z-50/Tr50 (screw core  $\varnothing = 39.8 \text{ mm}$ )

	GSZ-2	Z-5	Z-10	Z-25	Z-35/50	Z-50/Tr50	Z-100	Z-150	Z-250	Z-350	Z-500	Z-750	Z-1000
Trapezoidal screw Tr	16x4	18x4	20x4	30x6	40x7	50x8	55x9	60x9	80x16	100x16	120x16	140x20	160x20
Core $\varnothing$ in mm (minimum)	10.9	12.9	14.9	22.1	31.0	39.8	43.6	48.6	59.6	80.6	99.6	115.0	135.0
Ball screw KGT $\varnothing$ mm	16	16	25	32	40	-	50	63	80	100	125	140	160
Core $\varnothing$ in mm (minimum*)	12.9	12.9	21.5	27.3	34.1	-	43.6	51.8	67	87.4	107.8	117	132.8

\*Depending on the pitch, the core  $\varnothing$  may be even larger. See the KGT pages in Sections 2 and 3 for the exact core  $\varnothing$  values.

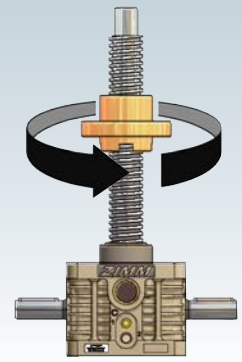

## Critical whirling speed for R gearboxes

### Maximum permissible screw rotational speed

$$n_{zul} = 0.8 \times n_{kr} \times f_{kr}$$

$n_{zul}$  Maximum permissible screw speed (rpm)

$n_{kr}$  Theoretical critical screw speed (rpm) leading to resonant vibrations (see diagram)

$f_{kr}$  Correction factor which makes allowance for the type of screw bearing

**i** The operating rotational speed must not exceed 80% of the maximum rotational speed

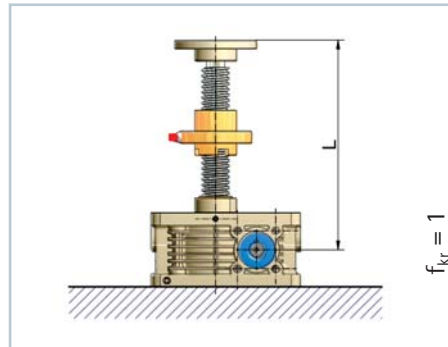

with end mounted bearings  
(preferred solution)

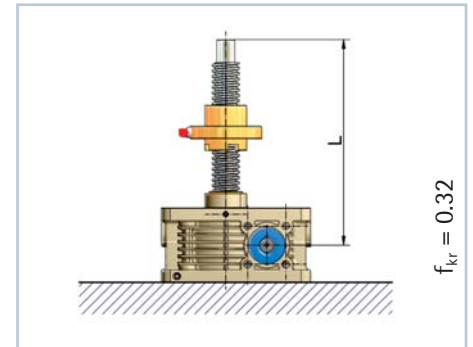

without end mounted bearings  
(avoid as far as possible)

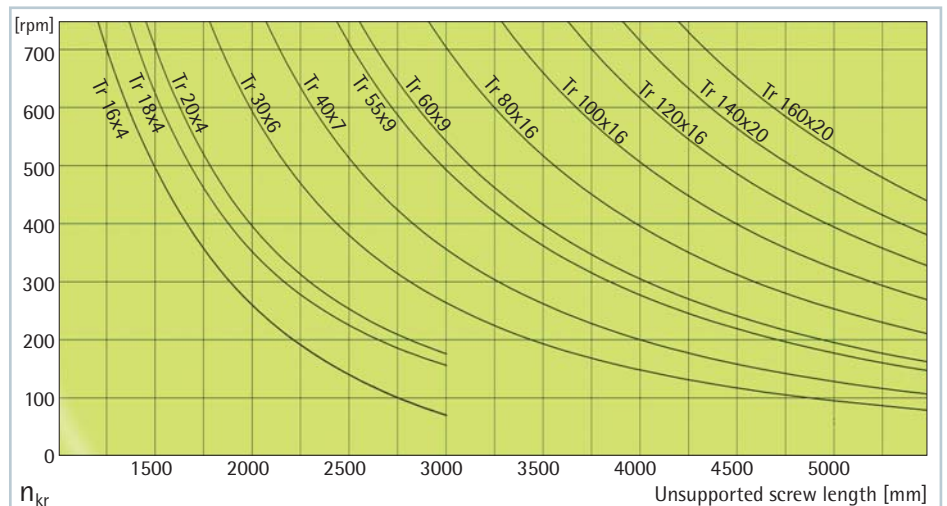

$$\text{Screw speed} = \frac{\text{Input drive speed}}{i_{\text{gearbox}}}$$

The maximum allowable screw speed must be calculated for R version gearboxes (with rotating screws) with long thin screws. To do this, read the theoretical critical speed  $n_{kr}$  from the diagram. Take into account also the additional lengths for screw covers etc. when calculating unsupported screw lengths. Now use the formula together with the correction factor for the screw bearing arrangement to calculate the maximum allowable screw speed.

If the calculated maximum screw speed is lower than the required speed, select a larger screw or a double-pitch screw with half the speed. This must then be checked also. You have the option to use a "increased screw" for the R version (screw for the next larger gearbox).

Bear in mind that a larger pitch demands a higher drive torque.

### CAUTION:

Long, thin screws can tend to squeak even though they satisfy the critical whirling speed! Therefore allow a sufficient margin of safety in the calculation.

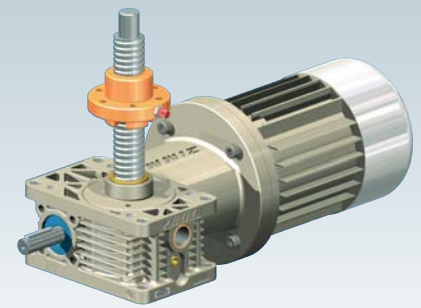

## Determining the drive torque [ $M_G$ ] of a single screw jack

### Explanatory notes:

$M_G$	necessary drive torque [Nm] for a screw jack
$F$	Lifting load (dynamic) [kN]
$\eta_{\text{gearbox}}$	Efficiency of the screw jack (without screw)
$\eta_{\text{screw}}$	Efficiency of the screw
$P$	Screw pitch [mm]
$i$	Drive ratio of the screw jack
$M_L$	Idling torque [Nm]
$P_M$	Motor drive power

The following specifications serve to calculate the required drive torque.

For gearboxes with single-pitch trapezoidal screws the load can simply be multiplied by the factor stated on the corresponding gearbox page (Sections 2 + 3).

**i** Use at least 10% of the gearbox rated load for the calculation, even if the effective load is less than this (i.e. for the Z-250 use at least 25 kN).

### Formula:

$$1) \text{ Drive torque: } M_G = \frac{F \text{ [kN]} \cdot P \text{ [mm]}}{2 \cdot \pi \cdot \eta_{\text{gearbox}} \cdot \eta_{\text{screw}} \cdot i} + M_L \text{ [Nm]}$$

$$2) \text{ Motor power: } P_M \text{ [kW]} = \frac{M_G \text{ [Nm]} \cdot n \text{ [rpm]}}{9550}$$

3) We recommend multiplying the calculated value by a safety factor of 1.3 to 1.5 (up to 2 for small systems and for low speeds).



### Example:

Z-25-SN

$F = 12 \text{ kN}$  (dynamic lift load)

$\eta_{\text{gearbox}} = 0.87$      $\eta_{\text{screw}} = 0.391$

$P = 6$                        $i = 6$

$$1) M_G = \frac{12 \text{ kN} \cdot 6 \text{ mm}}{2 \cdot \pi \cdot 0.87 \cdot 0.391 \cdot 6} + 0.36 \text{ Nm} = 5.97 \text{ Nm}$$

$$2) P_M = \frac{5.97 \text{ Nm} \cdot 1500 \text{ rpm}}{9550} = 0.938 \text{ kW}$$

3) Example:  $0.938 \text{ kW} \cdot 1.5 = 1.407 \text{ kW} \rightarrow$  motor 1.5 kW

### Efficiencies of the screw jack $\eta_{\text{gearbox}}$ (without screw)

i	rpm	GSZ-2	Z-5	Z-10	Z-25	Z-35	Z-50	Z-100	Z-150	Z-250	Z-350	Z-500	Z-750	Z-1000
N	3000	0.87	0.81	0.83	0.87	-	-	-	-	-	-	-	-	-
N	1500	0.87	0.82	0.84	0.87	0.87	0.87	0.88	0.89	0.91	-	-	-	-
N	1000	0.86	0.82	0.82	0.86	0.87	0.86	0.87	0.89	0.90	0.91	0.92	0.88	0.90
N	750	0.86	0.82	0.84	0.85	0.86	0.85	0.87	0.88	0.90	0.91	0.92	0.88	0.90
N	500	0.85	0.82	0.84	0.83	0.85	0.84	0.85	0.87	0.89	0.90	0.92	0.87	0.89
N	100	0.74	0.77	0.79	0.78	0.78	0.78	0.78	0.80	0.83	0.86	0.87	0.81	0.84
L	3000	0.78	0.74	0.78	0.76	-	-	-	-	-	-	-	-	-
L	1500	0.77	0.70	0.74	0.72	0.64	0.66	0.67	0.67	0.78	-	-	-	-
L	1000	0.75	0.67	0.72	0.70	0.64	0.66	0.65	0.66	0.77	0.78	0.76	0.67	0.76
L	750	0.74	0.65	0.70	0.68	0.64	0.66	0.65	0.65	0.76	0.78	0.75	0.66	0.76
L	500	0.71	0.62	0.67	0.65	0.63	0.65	0.65	0.63	0.75	0.77	0.73	0.65	0.75
L	100	0.54	0.53	0.59	0.54	0.52	0.55	0.57	0.53	0.65	0.67	0.61	0.58	0.66

### Efficiencies of the screws $\eta_{\text{screw}}$

calculated for coefficient of friction  $\mu = 0.11$

Tr screw, single-pitch	16x4	18x4	20x4	30x6	40x7	50x8	55x9	60x9	80x16	100x16	120x16	140x20	160x20	Ball screw
Efficiency	0.453	0.420	0.391	0.391	0.357	0.335	0.340	0.320	0.391	0.335	0.293	0.308	0.278	
Tr screw, double-pitch	16x8P4	18x8P4	20x8P4	30x12P6	40x14P7	50x16P8	55x18P9	60x18P9	80x32P16	100x32P16	120x32P16	140x40P20	160x40P20	
Efficiency	0.623	0.591	0.563	0.563	0.526	0.502	0.508	0.484	0.563	0.502	0.453	0.471	0.436	

### Idling torques $M_L$ of screw jacks [Nm] (without screw, at 20°C - significantly higher at low temperatures)

Z	2	5	10	25	35	50	100	150	250	350	500	750	1000
N	0.08	0.10	0.26	0.36	0.56	0.76	1.68	1.90	2.64	3.24	3.96	7.28	9.70
L	0.06	0.08	0.16	0.26	0.40	0.54	1.02	1.20	1.94	2.20	2.84	4.42	5.90

These are indicative values for calculation. Series production models may vary!



## Maximum torques

### Maximum input torque

In order to achieve optimum service life, do not exceed the values shown.  
If operating hours are lower, higher values may be achieved. Please contact us for advice.

#### max. input drive torques $M_R$ [Nm]

i	rpm	GSZ-2	Z-5	Z-10	Z-25	Z-35	Z-50	Z-50/Tr50	Z-100	Z-150	Z-250	Z-350	Z-500	Z-750	Z-1000
N	3000	1.2	4.0	11.0	17.0	-	-	-	-	-	-	-	-	-	-
N	1500	1.4	4.7	13.5	18.0	19.8	31.5	31.5	53.4	75.1	152	-	-	-	-
N	1000	1.5	5.6	14.0	22.0	20.8	36.8	36.8	60.8	77.1	152	265	408	480	680
N	500	1.6	6.1	16.7	28.0	24.8	46.5	46.5	75.3	95.0	160	350	500	640	960
L	3000	0.5	1.4	5.7	8.5	-	-	-	-	-	-	-	-	-	-
L	1500	0.5	1.5	7.5	10.0	9	10.4	10.4	13.5	20.7	41.4	-	-	-	-
L	1000	0.5	1.8	8.7	11.0	9.7	14.9	14.9	15.4	23.7	47.4	100	170	210	450
L	500	0.6	2.2	10.7	14.0	11.1	19.2	19.2	18.9	29.4	63.5	112	220	240	580

The stated limit values are mechanically-based - thermal factors may be relevant depending on the duty cycle

### max. drive-through torque

Where several gearboxes are arranged in series the drive-through torque may be significantly greater than the maximum input drive torque. Only the torsional load on the shaft needs to be considered, not the load on the gear teeth.

#### max. worm shaft drive-through torque [Nm]

GSZ-2	Z-5	Z-10	Z-25	Z-35	Z-50	Z-50/Tr50	Z-100	Z-150	Z-250	Z-350	Z-500	Z-750	Z-1000
9	39	57	108	130	260	260	540	540	770	1800	1940	4570	4570



## Drive torque for screw jacks - approximate calculation

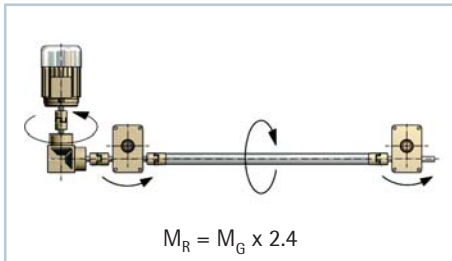

### Calculation

The drive torque required for a lifting system is the sum of the torques for the individual screw jacks and increases due to frictional losses on transfer components such as couplings, connecting shafts, bevel gearboxes etc.

To simplify the calculation, the following factors are used to determine the drive torque for the most common system layouts.

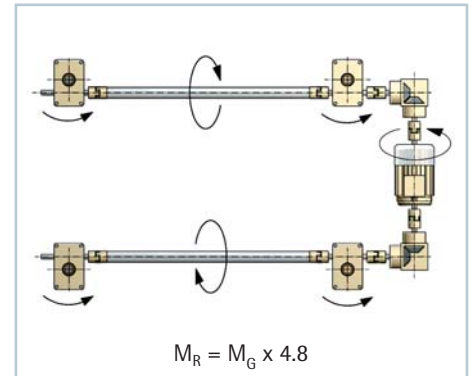
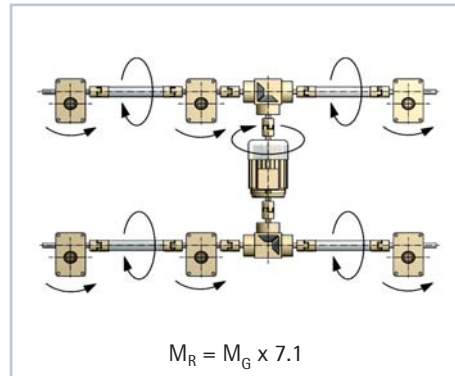
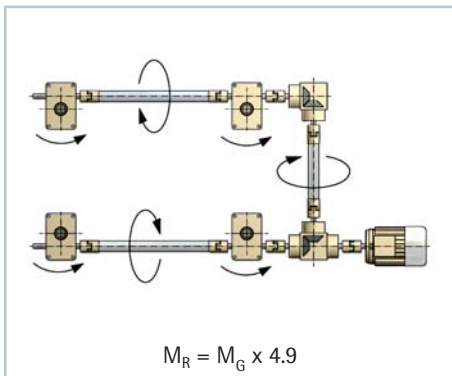
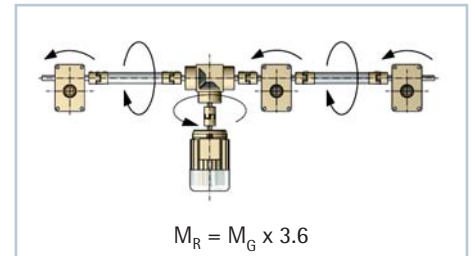
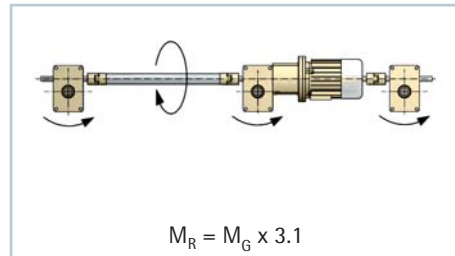
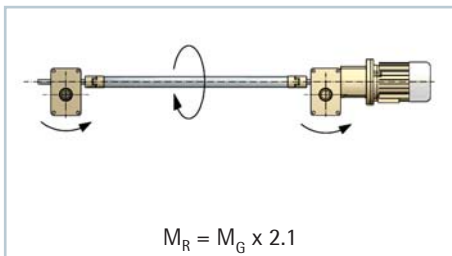

$M_R$  - Overall drive torque for the entire system.

$M_G$  - Drive torque for an single gearbox

$M_A$  - Starting torque max.  $1.5 \times M_R$

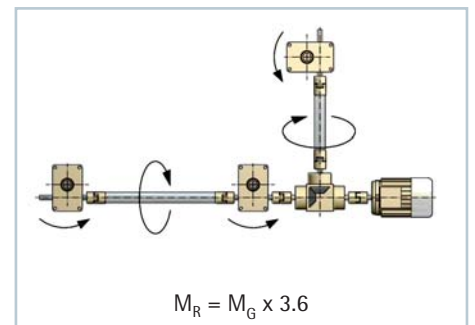
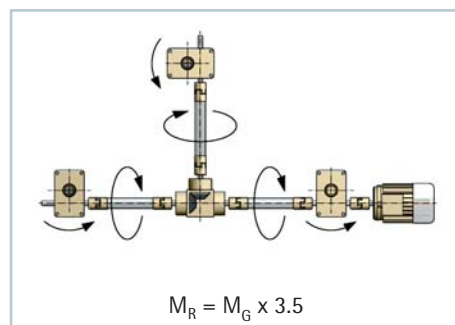

Example (example from page 162, 12 kN per gearbox)

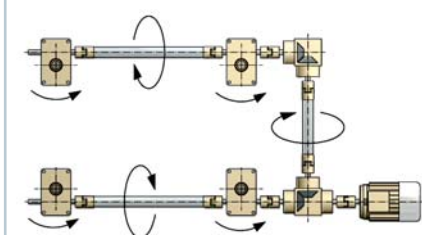

$$M_R = M_G \times 4.9 = 5.97 \text{ Nm} \times 4.9 = 29.25 \text{ Nm}$$

→ x safety factor 1.4 = 40.95 Nm

### CAUTION:

We recommend multiplying the calculated value by a safety factor of 1.3 to 1.5 (up to 2 for small systems and for low speeds). The values stated assume equal distribution of the load across all gearboxes!

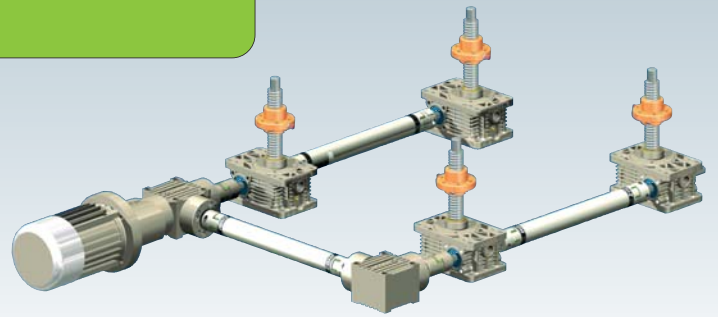

## Drive torque for screw jacks – precise calculation

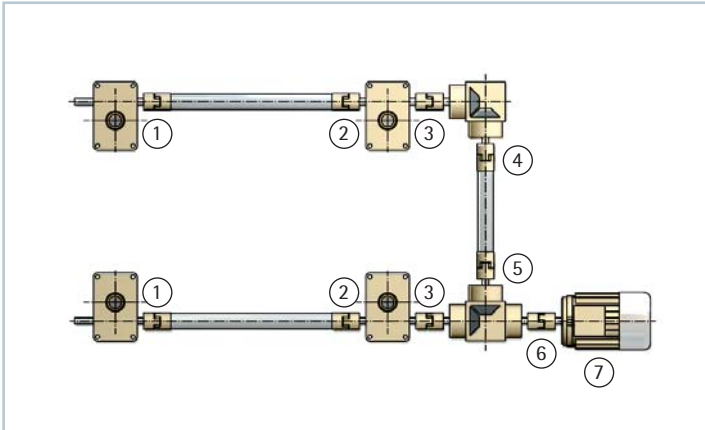

The following calculation example takes account of the efficiency of the connecting shafts ( $\eta$  0.95) and bevel gearboxes ( $\eta$  0.9).

### Formula for the gearbox::

$$\text{Drive torque: } M_G = \frac{F [\text{kN}] \cdot P [\text{mm}]}{2 \cdot \pi \cdot \eta_{\text{gearbox}} \cdot \eta_{\text{screw}} \cdot i} + M_L [\text{Nm}]$$

### Efficiencies:

Connecting shafts:	$\eta$ 0.95
Bevel gearbox:	$\eta$ 0.90

### Example:

$$1) \quad M_G = \frac{12 \text{ kN} \cdot 6 \text{ mm}}{2 \cdot \pi \cdot 0.87 \cdot 0.391 \cdot 6} + 0.36 \text{ Nm} = 5.97 \text{ Nm}$$

$$2) \quad \frac{5.97 \text{ Nm}}{0.95} = 6.28 \text{ Nm}$$

(efficiency of the connecting shaft)

$$3) \quad 5.97 \text{ Nm} + 6.28 \text{ Nm} = 12.25 \text{ Nm}$$

$$4) \quad \frac{12.25 \text{ Nm}}{0.9} = 13.61 \text{ Nm}$$

(efficiency of the bevel gearbox)

$$5) \quad \frac{13.61 \text{ Nm}}{0.95} = 14.33 \text{ Nm}$$

$$6) \quad 12.25 \text{ Nm} + 14.33 \text{ Nm}/0.9 = 29.53 \text{ Nm}$$

$$7) \quad 29.53 \text{ Nm} \cdot 1.4 = 41.34 \text{ Nm}$$

We recommend multiplying the calculated value by a safety factor of 1.3 to 1.5 (up to 2 for small systems and for low speeds).



### Z-25-SN

F = 12 kN (dynamic lift load per gearbox)

$\eta_{\text{gearbox}} = 0.87$       $\eta_{\text{screw}} = 0.391$

P = 6     i = 6

$12.25 \text{ Nm} \cdot 1.5 = 18.38 \text{ Nm}$   
 -> so KSZ-25-L is OK (see Section 5)

41.34 Nm -> we need a KSZ-50-L  
 (see Section 5)

Motor selection: 132M-P4-7.5 kW (50 Nm)  
 (for motors see Section 4)

## maximum forces / torques

### Loading definitions:

- $F$  - Lifting load tensile and/or compressive
- $F_S$  - Lateral loads on the screw
- $v_H$  - Lifting speed of the screw  
(or nut if the R version)
- $F_A$  - Axial load on the input shaft
- $F_R$  - Radial load on the input shaft
- $M_R$  - Input torque
- $n_R$  - Input speed

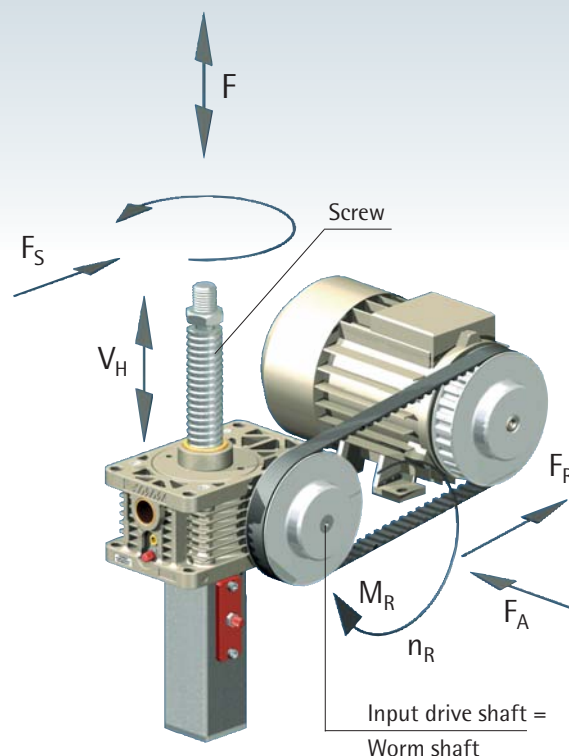

### Lateral forces on the lifting screw

The maximum permissible lateral forces are shown in the table on the right. Lateral forces should generally be taken by linear guides. The guide bushing in the gearbox functions only as a secondary guide. The maximum lateral forces actually occurring must be less than the values shown in the table!

**CAUTION:** only applies to static forces.

maximum lateral force  $F_S$  [N] (only static)

extended screw length in mm

Z	100	200	300	400	500	600	700	800	900	1000	1200	1500	2000	2500	3000
5	360	160	100	70	55	45	38	32	28	25	20	18	12	-	-
10	600	280	180	130	100	80	70	60	50	47	40	30	20	15	-
25	900	470	300	240	180	150	130	110	100	90	70	60	45	35	30
35	1300	700	450	360	270	220	190	160	150	130	100	90	60	50	40
50	3000	2000	1300	900	700	600	500	420	380	330	280	230	160	130	100
100	5000	4000	3000	2300	1800	1500	1300	1100	950	850	700	600	400	350	250
150	5500	5000	3900	2800	2300	1800	1500	1300	1200	1000	850	750	500	400	350
250	9000	9000	6500	4900	3800	3000	2500	2200	2000	1900	1450	1250	900	760	660
350	15000	13000	12000	10000	8800	7000	6000	5500	4800	4300	3500	3000	2000	1600	1400
500	29000	29000	29000	29000	29000	24000	20000	17000	15000	14000	12000	9000	7000	5600	4900
750	34800	34800	34800	34800	34800	28800	24000	20400	18000	16800	14400	10800	8400	6720	5880
1000	46000	46000	39000	36000	32000	30000	25000	29000	25000	23500	20000	17000	12000	10000	8000

### Radial load on the input shaft

Make sure that the radial forces arising where chain or belt drives are used do not exceed the values stated in the table alongside.

maximum radial load on the input shaft  $F_R$  [N]

	Z-5	Z-10	Z-25	Z-35	Z-50	Z-100	Z-150	Z-250	Z-350	Z-500	Z-750	Z-1000
$F_R$ max.	110	190	260	260	420	650	670	1100	1400	2600	3000	3400





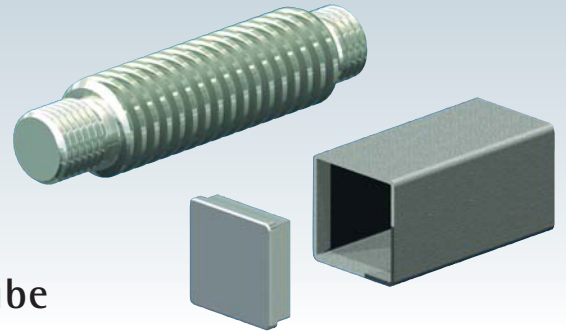

## Length calculation – screw and protective tube

### A quicker method

The tables on the following pages allow you to calculate the required screw length and protective tube extension length yourself. This lets you quickly calculate the fitting dimensions of your screw jack.

### Principle

Depending on the version and accessories used the screw (and the protective tube on the S version) are extended. These dimensions are minimum requirements. For special fitting situations, please provide a drawing or contact our project technicians.

### Stroke + basic length (+ various extensions for variants/accessories)

#### Example S:

Z-25-SN, stroke: 250 mm  
 Bellows Z-25-FB-300 (ZD=70mm)  
 Fixing flange BF (means the bellows do not require an fixing ring)  
 Rotation protection VS  
 Limit switch ES

#### Screw length Tr:

$$\begin{array}{rcccccc}
 250 & + & 180 & + & 44 & + & 45 & = & 519 \text{ mm} \\
 \text{Stroke} & & \text{Basic length} & & \text{Bellows} & & \text{Limit switch +} & & \text{Screw length} \\
 & & & & (70-26=44) & & \text{rotation protection} & & \\
 & & & & \text{Section 4} & & & & 
 \end{array}$$

#### Protective tube length SRO:

$$\begin{array}{rcccccc}
 250 & + & 53 & + & 72 & = & 375 \\
 \text{Stroke} & & \text{Basic length} & & \text{Limit switch +} & & \text{Protective tube length} \\
 & & & & \text{Rotation protection} & & 
 \end{array}$$

#### Example R:

Z-25-RN, stroke 250 mm  
 Screw with end support (opposed bearing plate GLP)  
 Bellows Z-25-FB-300 (ZD=70mm) above and underneath  
 Duplex nut DM

#### Screw length Tr:

$$\begin{array}{rcccccc}
 250 & + & 139 & + & 60 & + & 55 & + & 50 & = & 554 \text{ mm} \\
 \text{Stroke} & & \text{Basic length} & & \text{Bellows gearbox side} & & \text{2nd bellows} & & \text{Duplex nut} & & \text{Screw length} \\
 & & & & (70-10=60) & & (70-15=55) & & & & 
 \end{array}$$

See Section 4 for the length calculation for connecting shafts.

## Abbreviations:

Tr	Trapezoidal screw	KGT	Ball screw
AS	Escape protection	KAR	Pivot bearing plate
BF	Fixing flange	KGK	Rod end
ES	Limit switch	SLK	Pivot bearing end
FBR	Bellows fixing ring	ZD	Compressed length
GK	Forked end		

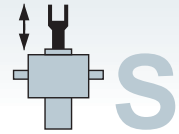
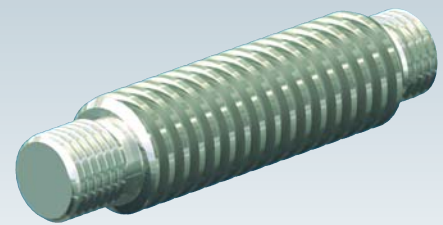

## Length calculation – screw, translating version S

(The length calculation is identical for Z and GSZ)

GSZ-2 to Z-150:		GSZ-2	Z-5	Z-10	Z-25	Z-35	Z-50	Z-50/Tr50	Z-100	Z-150
Tr basic length	Tr	118	139	161	180	219	240	263	338	342
KGT basic length	KGT	-	16x05 203	25x05 240	32x05 272	-	40x05 324	-	50x10 <sup>3)</sup> 420	63x10 <sup>5)</sup> 432
		-	16x10 224	25x10 260	32x10 282	-	40x10 324	-	50x20 <sup>3)</sup> 460	63x20 <sup>6)</sup> 506
		-	-	25x25 330	32x20 312	-	40x20 354	-	50x10 <sup>4)</sup> 456	63x10 <sup>7)</sup> 460
		-	-	25x50 460	32x40 382	-	40x40 414	-	50x20 <sup>4)</sup> 496	63x20 <sup>7)</sup> 500
		-	-	-	-	-	-	-	50x40 <sup>4)</sup> 576	63x40 <sup>7)</sup> 580
		-	-	-	-	-	-	-	-	-
Tr basic length with safety nut	Tr	-	-	219	239	280	305	-	411	423
Escape/rotation protection AS/VS	Tr/KGT	15	15	20	20	30	30	30	30	30
Limit switch ES <sup>2)</sup>	Tr	43	43	45	45	59	55	55	45	45
ES <sup>2)</sup> and pivot bearing plate KAR	Tr	65	64	65	69	85	80	80	90	95
Limit switch ES <sup>2)</sup>	KGT	-	16x05 38	25x05 40	32x05 40	-	40x05 50	-	50x10 45	63x10 45
		-	16x10 28	25x10 30	32x10 35	-	40x10 50	-	50x20 30	63x20 30
		-	-	25x25 20	32x20 20	-	40x20 35	-	50x40 30	63x40 30
		-	-	25x50 20	32x40 20	-	40x40 30	-	-	63x60 30
ES <sup>2)</sup> and pivot bearing plate KAR	KGT	-	16x05 59	25x05 60	32x05 64	-	40x05 75	-	50x10 90	63x10 95
		-	16x10 49	25x10 50	32x10 59	-	40x10 75	-	50x20 70	63x20 75
		-	-	25x25 20	32x20 44	-	40x20 60	-	50x40 30	63x40 35
		-	-	25x50 20	32x40 20	-	40x40 30	-	-	63x60 30
Bellows with bellows fixing ring (GK/KGK) <sup>1)</sup>	ZD-1	ZD-2	ZD+1	ZD+5	ZD+10	ZD+10	ZD+8	ZD-2	ZD-2	
Bellows without bellows fixing ring (BF/SLK) <sup>1)</sup>	ZD-18	ZD-22	ZD-24	ZD-26	ZD-36	ZD-36	ZD-40	ZD-50	ZD-22	
Bellows and KAR with FBR (GK/KGK) <sup>1)</sup>	ZD+32	ZD+31	ZD+28	ZD+46	ZD+63	ZD+63	ZD+81	ZD+60	ZD+68	
Bellows and KAR without FBR (BF/SLK) <sup>1)</sup>	ZD+15	ZD+11	ZD+3	ZD+15	ZD+17	ZD+17	ZD+33	ZD+12	ZD+48	

Z-250 to Z-1000:		Z-250	Z-350	Z-500	Z-750	Z-1000
Tr basic length	Tr	370	424	552	619	643
KGT basic length	KGT	80x10 561	100x20 663	125x25 823	140x25 976	160x25 1024
		80x20 601	100x40 743	125x40 883	140x40 1036	160x40 1084
		80x40 681	100x60 823	125x60 963	140x60 1116	160x60 1164
		80x60 761	100x80 943	125x80 1043	140x80 1196	160x80 1244
Tr basic length with safety nut	507	-	-	-	-	
Escape/rotation protection AS/VS	Tr/KGT	30	35	40	40	40
Limit switch ES <sup>2)</sup>	Tr	43	46	40	48	48
Limit switch ES <sup>2)</sup>	KGT	80x10 43	100x20 35	125x25 40	140x25 40	160x25 40
		80x20 30	100x40 35	125x40 40	140x40 40	160x40 40
		80x40 30	100x60 35	125x60 40	140x60 40	160x60 40
		80x60 30	100x80 35	125x80 40	140x80 40	160x80 40
Bellows with bellows fixing ring (GK/KGK) <sup>1)</sup>	ZD-2	ZD-2	ZD-22	ZD-22	ZD-22	
Bellows without bellows fixing ring (BF/SLK) <sup>1)</sup>	ZD-22	ZD-22	ZD-42	ZD-42	ZD-42	

Safety distances are already included in the basic lengths!

(Tr screws: 10 mm up to Z-50, 20 mm for Z-100 to Z-500, 40 mm for Z-750 and Z-1000)

- The value will be added to or subtracted from the ZD dimension of the bellows depending on the sign and the result then added to the screw length. Applicable only to Tr single-pitch screws, not to double-pitch and KGT screws.
- Limit switches ES are always used in combination with rotation protection VS (VS is included in the extension).
- KGT 50: L6=82
- KGT 50: L6=118
- KGT 63: L6=90
- KGT 63: L6=124
- KGT 63: L6=118

**Screw extension for spiral spring cover SF:**  
Since the extension for spiral spring covers varies according to the fitting, this variant must be determined from a drawing. We would be pleased to prepare this drawing for you.

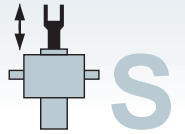
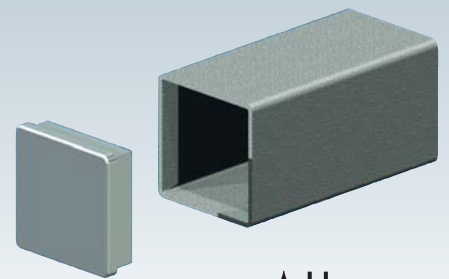

## Length Calculation – protective tube SRO, translating version S

(The length calculation is identical for Z and GSZ)

GSZ-2 to Z-150:		GSZ-2	Z-5	Z-10	Z-25	Z-35	Z-50	Z-50/Tr50	Z-100	Z-150
Tr basic length <sup>1)</sup>	Tr	47	46	49	53	57	62	62	82	87
KGT basic length <sup>1)</sup>	KGT	–	16x05 56	25x05 59	32x05 63	–	40x05 72	–	50x10 82	63x10 87
		–	16x10 76	25x10 79	32x10 73	–	40x10 72	–	50x20 122	63x20 127
		–	–	25x25 149	32x20 103	–	40x20 102	–	50x40 202	63x40 207
		–	–	25x50 279	32x40 173	–	40x40 162	–	–	63x60 287
Escape/rotation protection AS/VS	Tr/KGT	15	15	20	20	30	30	30	30	30
Limit switch ES <sup>3)</sup>	Tr	70	73	72	72	86	82	82	62	62
ES <sup>3)</sup> and pivot bearing plate KAR	Tr	92	94	92	96	112	107	107	107	112
Limit switch ES <sup>3)</sup>	KGT	–	16x05 63	25x05 62	32x05 62	–	40x05 72	–	50x10 62	63x10 62
		–	16x10 43	25x10 42	32x10 52	–	40x10 72	–	50x20 30	63x20 30
		–	–	25x25 20	32x20 22	–	40x20 42	–	50x40 30	63x40 30
		–	–	25x50 20	32x40 20	–	40x40 30	–	–	63x60 30
ES <sup>3)</sup> and pivot bearing plate KAR	KGT	–	16x05 84	25x05 82	32x05 86	–	40x05 97	–	50x10 107	63x10 112
		–	16x10 64	25x10 72	32x10 76	–	40x10 97	–	50x20 70	63x20 75
		–	–	25x25 20	32x20 46	–	40x20 67	–	50x40 30	63x40 35
		–	–	25x50 20	32x40 20	–	40x40 30	–	–	63x60 30

Z-250 to Z-1000 <sup>4)</sup> :		Z-250	Z-350	Z-500	Z-750	Z-1000
Tr basic length <sup>1)</sup>	Tr	92	107	157	157	157
KGT basic length <sup>1)</sup>	KGT	80x10 92	100x20 147	125x25 177	140x25 177	160x25 177
		80x20 132	100x40 227	125x40 237	140x40 237	160x40 237
		80x40 212	100x60 307	125x60 317	140x60 317	160x60 317
		80x60 292	100x80 387	125x80 397	140x80 397	160x80 397
Escape/rotation protection AS/VS	Tr/KGT	30	35	40	40	40
Limit switch ES <sup>3)</sup>	Tr	58	59	40	48	48
Limit switch ES <sup>3)</sup>	KGT	80x10 58	100x20 35	125x25 40	140x25 40	160x25 40
		80x20 30	100x40 35	125x40 40	140x40 40	160x40 40
		80x40 30	100x60 35	125x60 40	140x60 40	160x60 40
		80x60 30	100x80 35	125x80 40	140x80 40	160x80 40

CAUTION: minimum stroke with limit switch ES<sup>2)</sup>:

GSZ-2 to Z-150:	GSZ-2	Z-5	Z-10	Z-25	Z-35	Z-50	Z-50/Tr50	Z-100	Z-150
minimum stroke with limit switch ES	53	50	51	51	41	42	42	42	42
minimum stroke with ES and lubrication strip SL	123	120	121	121	111	112	112	112	112

Z-250 to Z-1000:	Z-250	Z-350	Z-500	Z-750	Z-1000
minimum stroke with limit switch ES	47	42	46	46	46
minimum stroke with ES and lubrication strip SL	117	112	116	116	116

- Basic length of the protective tube without a cap.  
The cap height is 5 mm.
- If a shorter stroke than specified is required, the limit switches and lubrication strip may be fitted on different faces.
- Limit switches ES are always used in combination with rotation protection VS (VS is included in the extension).
- Z-250 - Z-1000:
  - only screw, or screw with escape protection AS (round protective tube)
  - with rotation protection VS or VS + limit switch ES (square protective tube)

## Abbreviations:

Tr	Trapezoidal screw
KGT	Ball screw
KAR	Pivot bearing plate

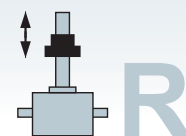

## Length Calculation – screw, rotating version R

(The length calculation is identical for Z and GSZ)

GSZ-2 to Z-150:	GSZ-2		Z-5		Z-10		Z-25		Z-35		Z-50		Z-100		Z-150	
Tr basic length without journal	78		86		102		114		132		148		222		250	
Tr basic length with journal (= standard for opposed bearing plate GLP)	90		101		122		139		162		178		267		305	
Tr basic length increased screw with journal <sup>1)</sup>	93		106		127		144		177		193		277		325	
KGT basic length with journal <sup>2)</sup>	16x05	100	16x05	111	25x05	132	32x05	149	40x05	172	40x05	188	50x10	267	63x10	305
	16x10	120	16x10	131	25x10	152	32x10	159	40x10	172	40x10	188	50x20	307	63x20	345
					25x25	222	32x20	189	40x20	202	40x20	218	50x40	387	63x40	425
					25x50	352	32x40	259	40x40	262	40x40	278	50x50	427	63x60	505
KGT basic length increased screw with journal <sup>1)2)</sup>			25x05	116	32x05	137	40x05	154	50x10	197	50x10	213	63x10	277	80x10	325
			25x10	136	32x10	147	40x10	154	50x20	237	50x20	253	63x20	317	80x20	365
			25x25	206	32x20	177	40x20	184	50x40	317	50x40	333	63x40	397	80x40	445
			25x50	336	32x40	247	40x40	244	50x50	357	50x50	373	63x60	477	80x60	525
KGT basic length without journal <sup>2)</sup>	16x05	88	16x05	96	25x05	112	32x05	124	40x05	142	40x05	158	50x10	222	63x10	250
	16x10	108	16x10	116	25x10	132	32x10	134	40x10	142	40x10	158	50x20	262	63x20	290
					25x25	202	32x20	164	40x20	172	40x20	188	50x40	342	63x40	370
					25x50	332	32x40	234	40x40	232	40x40	248	50x50	382	63x60	450
KGT basic length increased screw without journal <sup>1)2)</sup>			25x05	96	32x05	112	40x05	124	50x10	152	50x10	168	63x10	222	80x10	250
			25x10	116	32x10	122	40x10	124	50x20	192	50x20	208	63x20	262	80x20	290
			25x25	186	32x20	152	40x20	154	50x40	272	50x40	288	63x40	342	80x40	370
			25x50	316	32x40	222	40x40	214	50x50	312	50x50	328	63x60	422	80x60	450
Flange nut FM	35		35		44		46		66		66		-		90	
Duplex nut DM	45		45		45		50		70		70		90		115	
Self-aligning nut PM	-		78		83		95		129		129		190		210	
Greaseless duplex nut FFDMM	-		53		53		59		85		85		-		-	
DM + safety nut SIFA	70		70		84		95		133		133		173		211	
PM + safety nut SIFA	-		123		128		158		212		212		298		330	
1. Bellows <sup>3)</sup>	ZD-10		ZD-12		ZD-12		ZD-10		ZD-12		ZD-12		ZD-22		ZD-22	
2. Bellows <sup>3)</sup>	ZD-10		ZD-10		ZD-14		ZD-15		ZD-15		ZD-15		ZD-20		ZD-30	
KAR screw face and 1st bellows <sup>3)</sup>	ZD+23		ZD+21		ZD+15		ZD+31		-		-		-		-	
KGT flange nut KGF	add the respective nut length															

Z-250 to Z-1000:	Z-250		Z-350		Z-500		Z-750		Z-1000	
Tr basic length without journal	265		288		366		417		438	
Tr basic length with journal (= standard for opposed bearing plate GLP)	340		388		486		537		613	
Tr basic length increased screw with journal <sup>1)</sup>	365		408		486		592		-	
KGT basic length with journal <sup>2)</sup>	80x10	340	100x20	428	125x25	506	140x25	557	160x25	633
	80x20	380	100x40	508	125x40	566	140x40	617	160x40	693
	80x40	460	100x60	588	125x60	646	140x60	697	160x60	773
	80x60	540	100x80	668	125x80	726	140x80	777	160x80	853
KGT basic length without journal <sup>2)</sup>	80x10	265	100x20	328	125x25	386	140x25	437	160x25	458
	80x20	305	100x40	408	125x40	446	140x40	497	160x40	518
	80x40	385	100x60	488	125x60	526	140x60	577	160x60	598
	80x60	465	100x80	568	125x80	606	140x80	657	160x80	678
Duplex nut DM	140		160		180		220		320	
Self-aligning nut PM	224		275		-		-		-	
DM + safety nut SIFA	250		270		303		365		500	
PM + safety nut SIFA	369		455		-		-		-	
1. Bellows <sup>3)</sup>	ZD-22		ZD-22		-		-		-	
2. Bellows <sup>3)</sup>	ZD-40		ZD-60		-		-		-	
KGT flange nut KGF	add the respective nut length									

Safety distances are already included in the basic lengths (2x: 1x above and 1x underneath)!  
(Tr screws: 10 mm up to Z-50, 20 mm for Z-100 to Z-500, 40 mm for Z-750 and Z-1000)

- When using a larger diameter screw, select the components for the next size gearbox (Z-10 increased screw has a screw Tr 30x6 which means component Z-25 - this is then the calculated screw extension for size 25).
- The basic length for KGT screws includes the safety clearance L3 shown on the gearbox dimension sheet. The nut length must then be added to this.
- The value will be added to or subtracted from the ZD (compression) dimension of the bellows depending on the sign and the result then added to the screw length. Applicable only to Tr single-pitch screws, not to double-pitch and ball screws.

**Screw extension for spiral spring cover SF:**  
Since the extension for spiral spring covers varies according to the fitting, this variant must be determined from a drawing. We would be pleased to prepare this drawing for you.

# Ordering code

Gearbox type	Size	Version	Drive ratio	Screw version	Screw Ø / pitch	Number of screw starts, material	Stroke	List of accessories
[ ]	[ ]	[ ]	[ ]	[ ]	[ ] - [ ]	[ ] - [ ]	H	[ ] - [ ] - [ ] - [ ]
Z GSZ	2 5 10 25 35 50 100 150 250 350 500 750 1000	S Translating version  R Rotating version	N Normal e.g. i = 4:1  L Low speed e.g. i = 16:1	Tr Trapezoidal screw (not stated = Tr)  Tr/SIFA Tr with safety nut SIFA OP EL ELV ELD NO  KGT Ball screw	Tr 1804 2004 ...  KGT 1605 1610 ...	1 single-pitch (not stated = single-pitch)  2* double-pitch  I INOX (stainless steel)  LH* left-handed	Stroke H + stroke in mm	List of accessories (in any sequence) see Section 4

\*is available but not ex stock.  
Lead time on request

**i** For enquiries or orders you may optionally:  
 - either list the parts individually  
 - or define the complete screw jack in an ordering code in the format specified here

**Ordering example:**

Z-10-SN-Tr-2004-1-H 300-FB390-VS-BF

Gearbox, type  
 Size  
 Version S or R  
 Drive ratio N or L  
 Screw version  
 Screw diameter, screw pitch  
 Number of starts  
 Stroke  
 List of accessories (in any sequence)



## Innovative separate lubrication

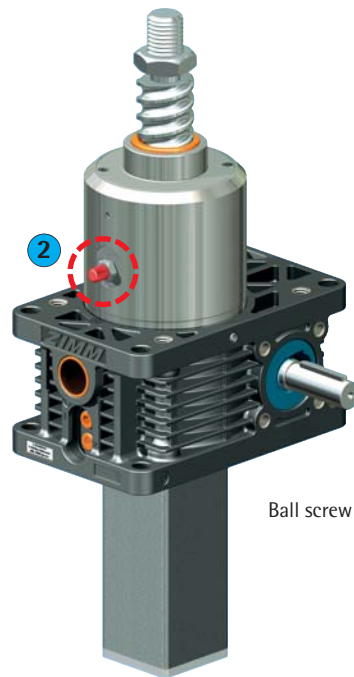
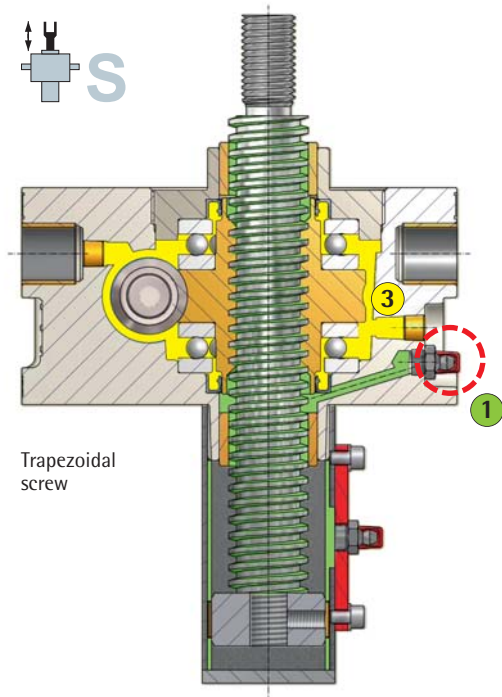

**i** The separate lubrication system is essential for high performance.

- 1** The **INNOVATION**: Screw lubrication **during operation** provides optimum grease distribution.
- 2** The same **INNOVATION** is also available for the ball screw version (KGT).

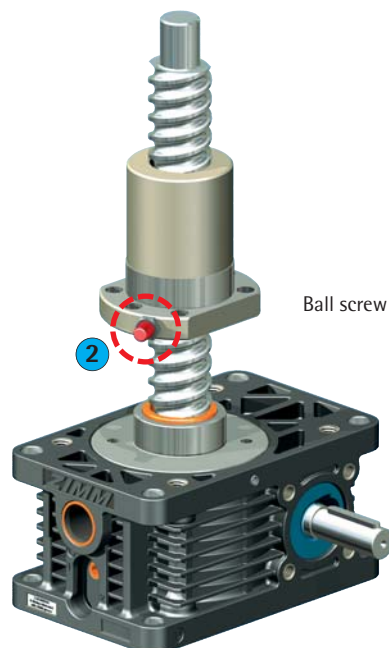
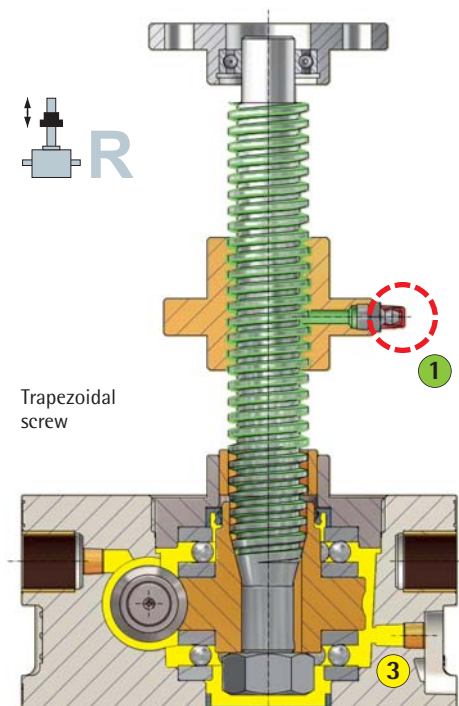

- 1** Screw lubrication **during operation** provides optimum grease distribution.
- 2** The same lubrication system is also available for the ball screw version (KGT).



## Screw lubrication

### 1 Trapezoidal screw

Inspect the trapezoidal screw regularly and regrease it depending on the operating cycle. Use the grease that we recommend. These greases are ideally matched to the operating requirements of our screw jack systems.



### 2 Ball screw KGT

Lubricate the ball screw KGT every 300 hours of effective operation. For heavy-duty systems every 100 hours.

Grease quantity: Guidance value approx. 1 ml per cm screw diameter.



### 3 Gearbox lubrication

The gearbox is sealed and is filled with high-performance synthetic grease (gearboxes from Z-250 are oil-filled). The gearbox is lubricated for life in normal operation.

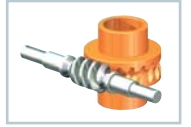

See Section 4 for the list of lubricants.

Cartridge 400 g



Lubricator  
Z-LUB, ZIMM lubricator



## Lubrication for short stroke applications

### S version:

For short stroke applications (stroke < gearbox height), take particular care to ensure lubrication of the trapezoidal screw.

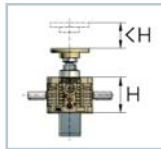

The simplest tactic is to specify the screw jack with a longer stroke than the gearbox height, and periodically perform a lubrication stroke. Otherwise, contact our Engineering Department for a suitable solution.

### R version:

If stroke length < nut height, use a nut with lubrication capability (such as a duplex nut DM).

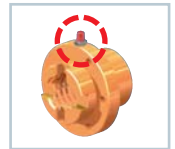

## General

### Special lubricants

For special applications and for the earlier MSZ gearboxes we can offer suitable lubricants in each case.

These include amongst others:

- High-temperature grease
- Low-temperature grease
- Food grade grease
- Clean room grease, etc.

### Other greases, contamination

Using multipurpose greases and other greases can significantly impair operation and shorten the service life.

If the screw becomes dirty, clean and regrease it.

### Long-life systems

The grease used in long-life systems (such as working platforms and theatre stages) loses its lubricating properties after about 5 years.

Dust and dirt penetration intensify this effect. We recommend complete cleaning and regreasing after 5 years.

If mineral greases are used, this may be necessary after only 2-3 years.

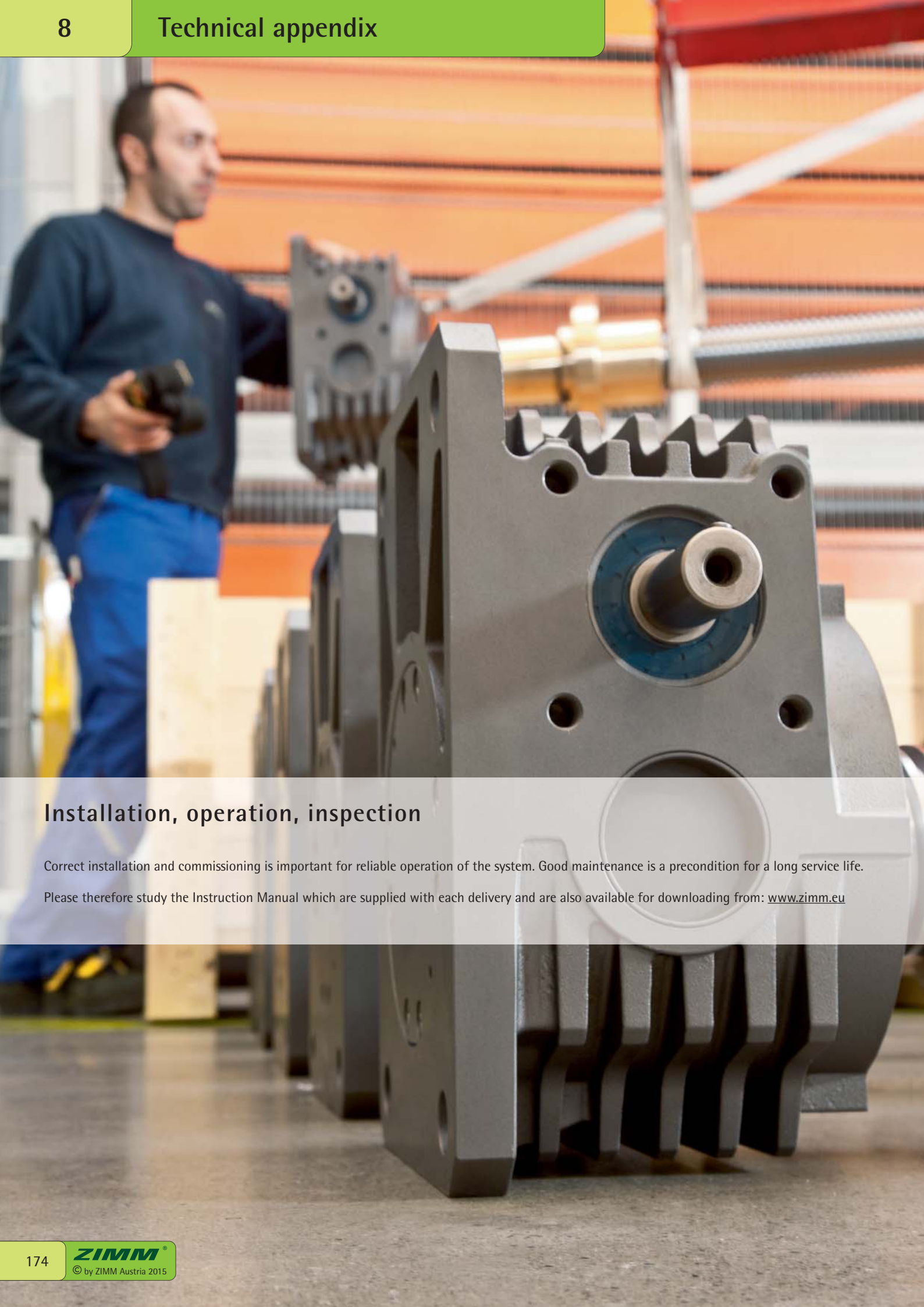

## Installation, operation, inspection

Correct installation and commissioning is important for reliable operation of the system. Good maintenance is a precondition for a long service life.

Please therefore study the Instruction Manual which are supplied with each delivery and are also available for downloading from: [www.zimm.eu](http://www.zimm.eu)





## Operational reliability and safety

**Operational reliability and safety**  
Operational reliability and safety are just as important for industrial systems as for theatre stages and other systems.



### Design and specification

During the design and specification phase, pay special attention to the load capacity of the drives and accessories in their proposed installation situation. Plan your system with appropriate safety for attachment, movement and transport elements.

Please note the design advice given in Section 8.

Where the system is safety-relevant, fit a safety nut SIFA. If the nut thread is stripped due to wear, the SIFA takes the load. An electronic control is available on request.



### Installation

Correct and careful installation is essential for trouble-free and safe system operation. Please refer to our instruction manual included with each delivery. You can download these from the Internet at [www.zimm.eu](http://www.zimm.eu)



### Inspection and maintenance

Regular inspection and maintenance are necessary to maintain reliability.



Check the following during the regular inspections:

Visual condition, attachments and connections, wear on the trapezoidal thread and the level of lubrication. Comply with our lubrication instructions and use only the lubricants we recommend. Please consider our automatic lubricator Z-LUB.

### Spare parts

To protect against loss of production caused by high duty cycles or high loads, we recommend keeping a set of screw jack spare parts (including screws, accessories and with assembly drawings) at your location or at your customer's location. A screw jack can most economically be repaired by a complete exchange.

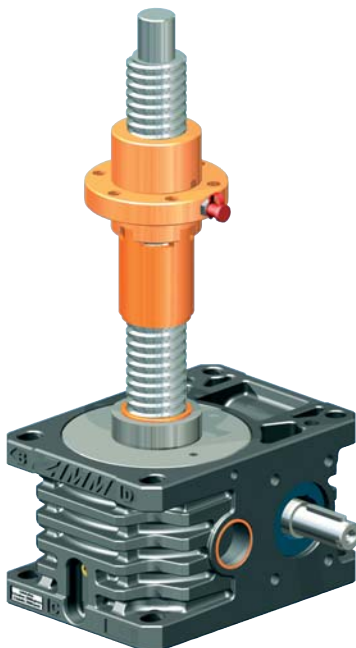

Screw jack with safety nut SIFA



ZIMM Instruction Manual in other languages and for special products are available on request or by downloading from [www.zimm.eu](http://www.zimm.eu)

## Temperature

The ambient temperature is very important for system operation.

Always inform us about ambient temperature and conditions, especially if these deviate from the usual 20°C to 25°C.

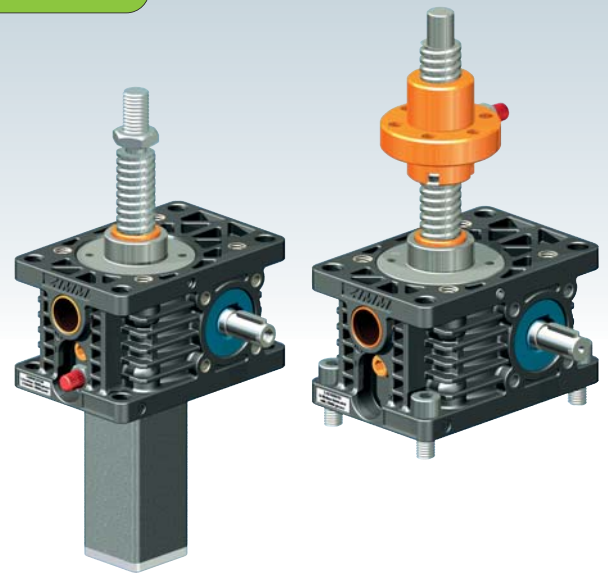

### Normal temperature

Always specify on your enquiry and order if the equipment will be exposed to ambient temperatures below 10°C or above 40°C.

The highest temperature rises in operation occur at the shaft seal ring and on the trapezoidal screw. The Tr spindle can achieve a rise in temperature double that at the gearbox.



#### Example:

In operation at an ambient temperature of 20°C, the gearbox reaches 60°C (rise of 40°C) and the Tr screw about 100°C (rise of 80°C).

The temperature of the Tr spindle should not be allowed to exceed 100°C.

### Low temperature

The seals and most of our lubricants we use are specified in principle for operating temperatures down to -40°C. However the design should be checked for suitability if operating temperatures below 10°C are envisaged. Lubricants become stiffer and the break-away torque becomes higher.

Generally speaking, all components must be sized adequately for temperatures below zero, because the material strength is reduced.



### High temperature

For operating temperatures above 60 °C we recommend the use of high-temperature grease in the gearbox, and the use of FPM seals. (standard paint finish up to 90 °C)

For operating temperatures above 100°C please contact us so that we can offer appropriate solutions.

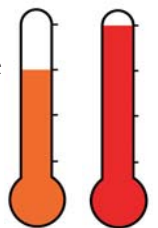

### Temperature range of standard parts:

Standard screw jacks	-20°C to +80°C (when <10°C or >40°C please contact us)
High temperature screw jacks	up to 160°C, or 200°C
Round bellows	-20°C to +70°C (max. +85°C)
Polygonal bellows	-15°C to +70°C (no exposure to direct sunlight)
Limit switch	-40°C to +70°C
Limit switch cable standard	-25°C to +70°C
Limit switch cable special	-40°C to +105°C
Rotary pulse encoder DIG	-40°C to +80°C
Motors	above 40°C reduced power, e.g. factor 0.8 at 60°C
Connecting shafts VWZ+KUZ-KK	0°C to + 70°C, reduced from -20°C to +100°C (max. +120°C)
Couplings KUZ	-20°C to +70°C, reduced from -30°C to +100°C
Bevel gearboxes	-10°C to +90°C
Ball screws KGT	-20°C to +80°C

For lower and higher temperatures, please request information on the component from us, with your checklist (Section 7).

### Ambient and operating temperatures:

The ambient temperature is relevant for components such as limit switches or bellows. For gearboxes, the operating temperature is slightly or considerably higher than the ambient temperature, depending on the duty cycle.



## Clean room

### Sectors

Various fields such as semiconductor production, flat screen production, optical and laser technology, spacecraft production etc. demand high cleanliness, which means that clean room standards must be maintained.

### Clean room

A clean room is a room where the concentration of particles in the air is controlled and satisfies defined cleanliness classes. It is important to keep the particle contamination caused by work materials, lubricants and drives to a minimum.

### Your system

Use the checklist in Section 7 to enquire about the system you require and also specify the particular requirements for your application. We can then offer you a system to meet your requirements.

## Food industry



### Food industry sector

The foodstuffs sector operates at a very high level of automation. On the one hand this promotes a very high level of hygiene, on the other hand it permits intelligent and efficient systems for economic production

### Resistant against corrosion

Our Z and GSZ series are corrosion-resistant and are therefore very suitable for most applications in the food industry. The GSZ gearbox with its smooth surfaces is particularly suitable.

The Z and GSZ series are not suitable for special applications where stainless steel is mandatory.

### Screw jack systems

We supply gearboxes and systems with food grade grease to the food industry. Our food grade greases are FDA-approved. Use the checklist in Section 7 to enquire about the system you require and also specify the particular requirements for your application.

## Resistant against corrosion

### Standard corrosion protection

When installed indoors in heated buildings with neutral ambient conditions.  
Max. surface temperatures up to 90°C.

All relevant components of the ZIMM Z series and GSZ series for these operating ranges are coated as standard against corrosion. The colours black, anthracite and silver are visually neutral and fit in with any colour combination.

### Enhanced corrosion protection

If installed outdoors or if subject to condensation or direct exposure to the weather.

Enhanced corrosion protection by additional coatings or special paint finishes, possibly stainless steel spindles, UV-resistant or moisture-resistant gaiters.

### Special corrosion protection

For environments containing chemical pollutants, in coastal areas and exposed to other aggressive conditions.

Special corrosion protection by the use of stainless steel components or other special measures.



## Screw jack application examples

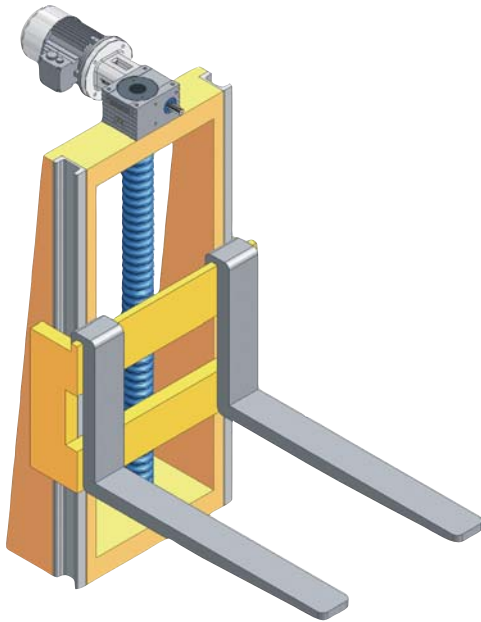

Translating lift for pallets

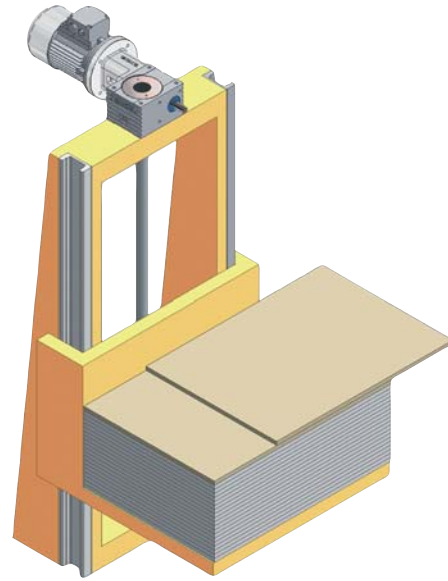

Unstacking unit for plate materials

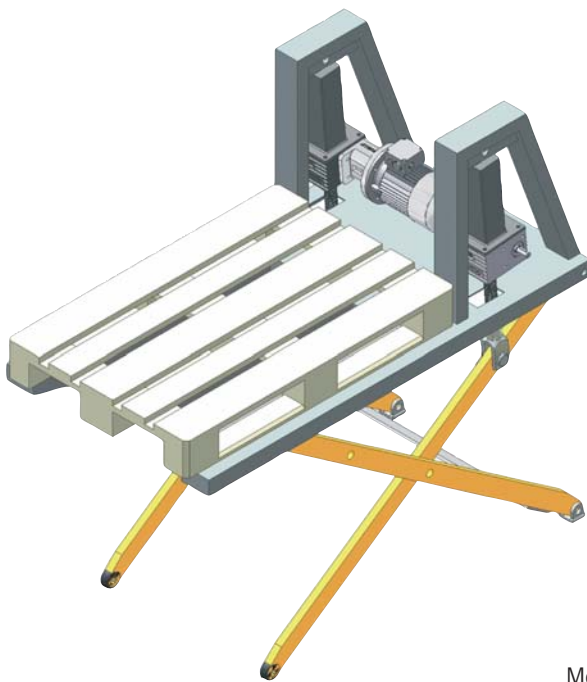

Mobile scissor table suitable for pallet truck transfer

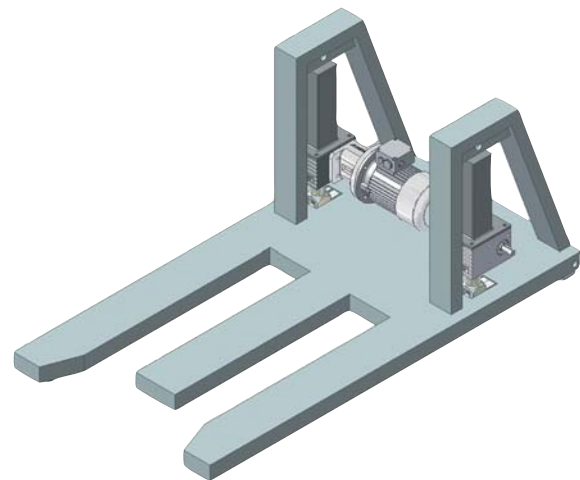

## Screw jack application examples

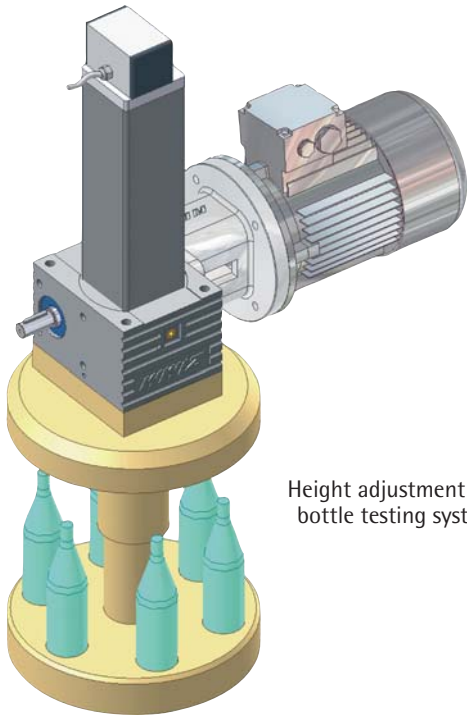

Height adjustment in a bottle testing system



Parabolic antenna  $D = 3.3$  m, both axes – azimuth + elevation – each 50 kN, travel for each movement 0.02 – 0.05 mm; system installed in the open air on the coast

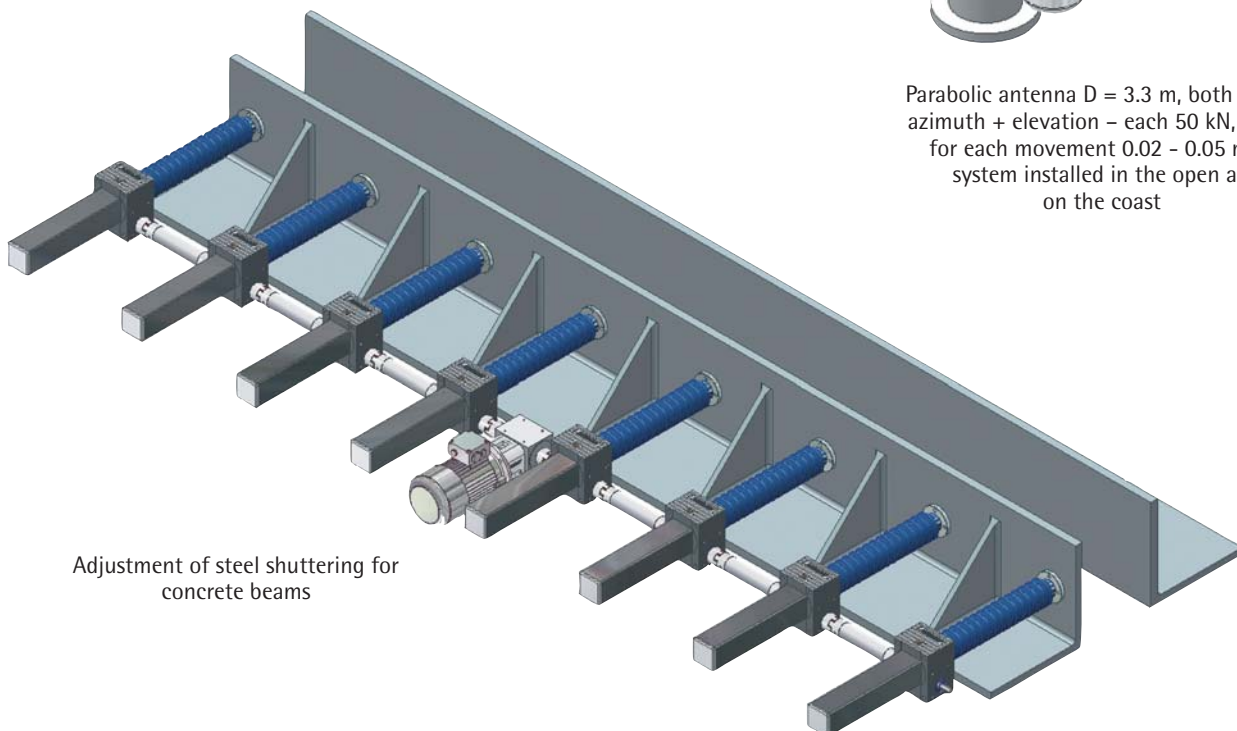

Adjustment of steel shuttering for concrete beams

## Screw jack application examples

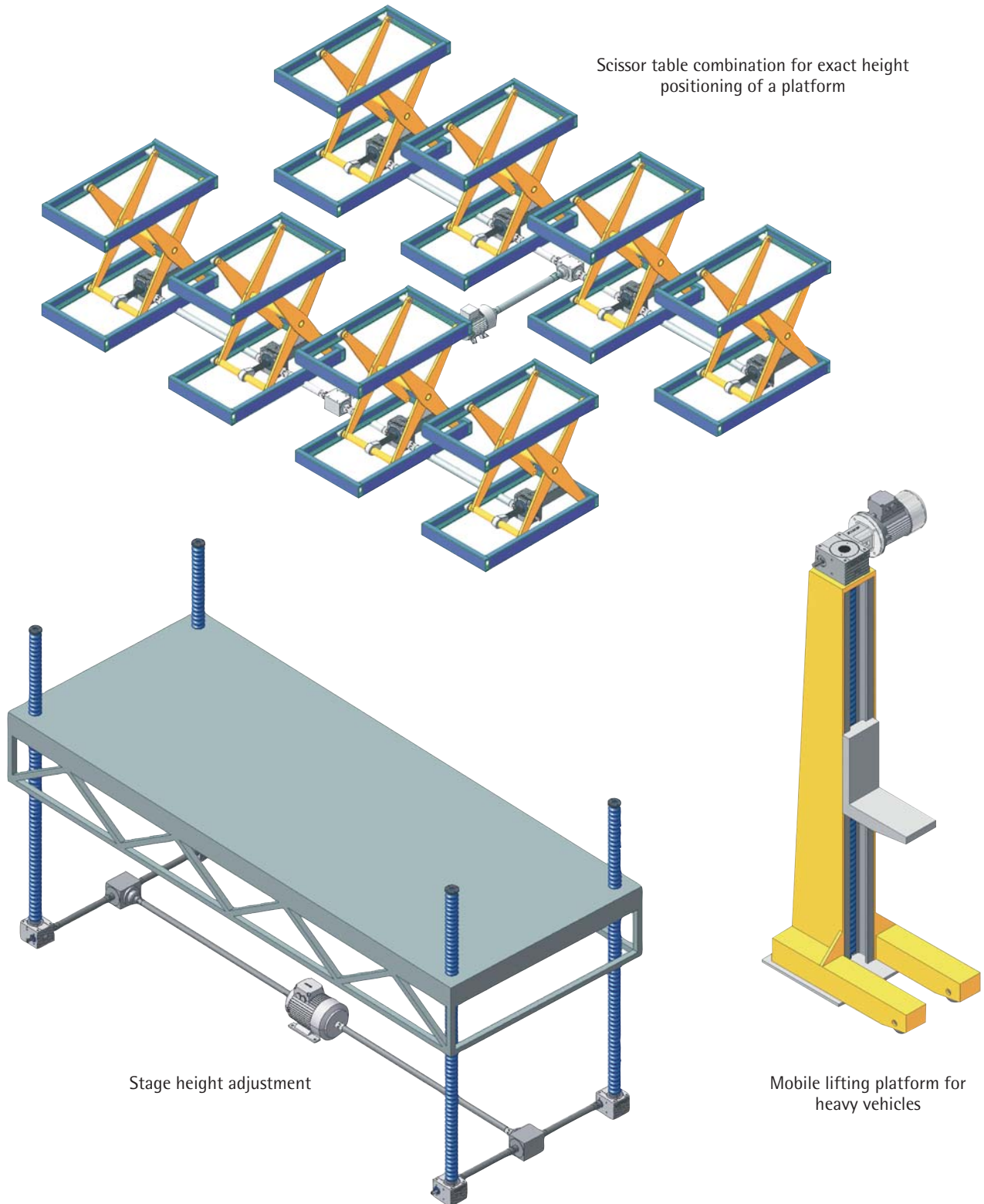

## Screw jack application examples

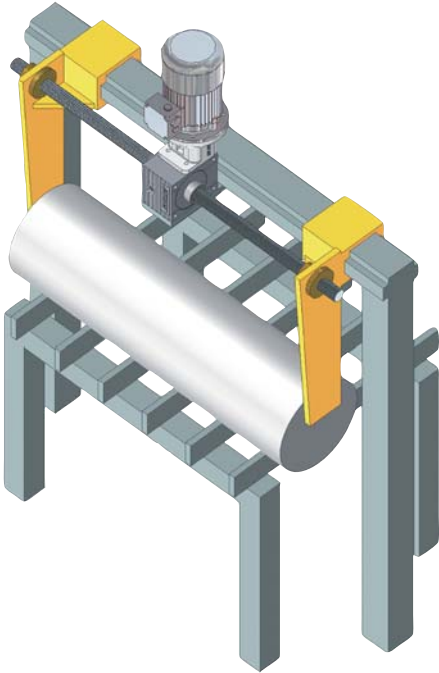

Centring mechanism using right  
and left threaded screws

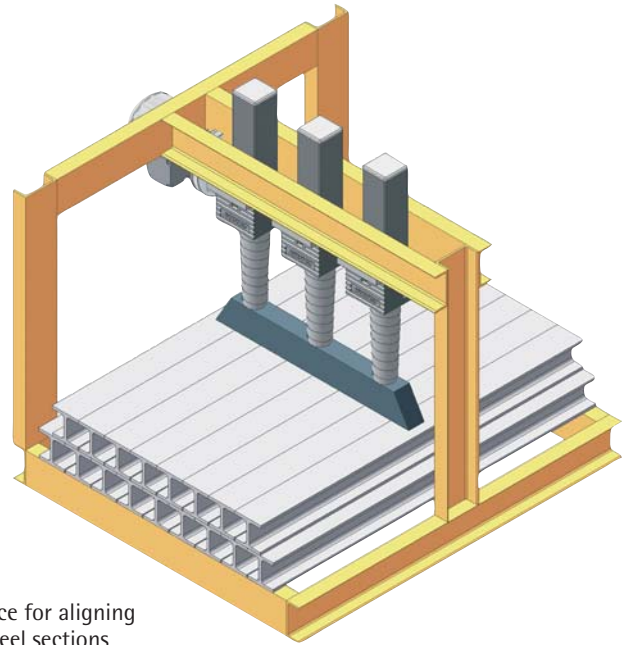

Device for aligning  
steel sections

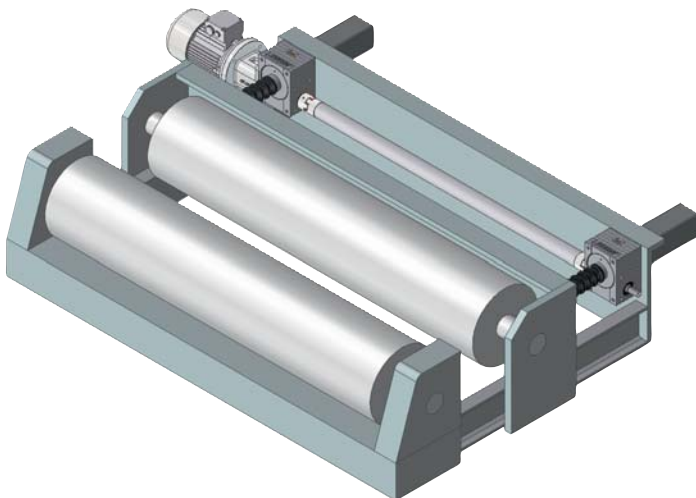

Adjustment system for bearings  
in the textile industry

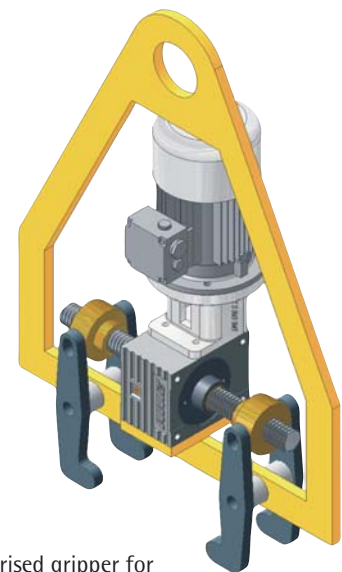

Motorised gripper for  
steel sections

## Screw jack application examples

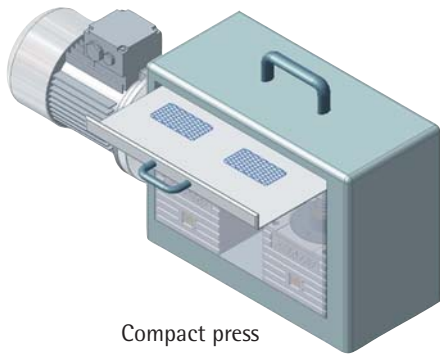

Compact press

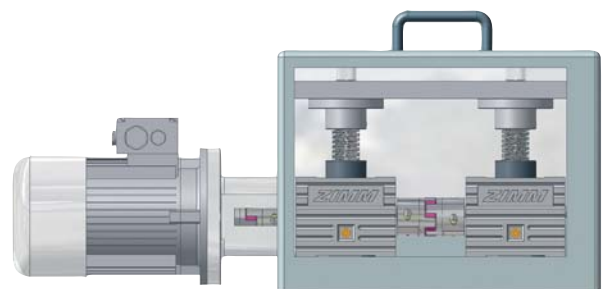

Compact press

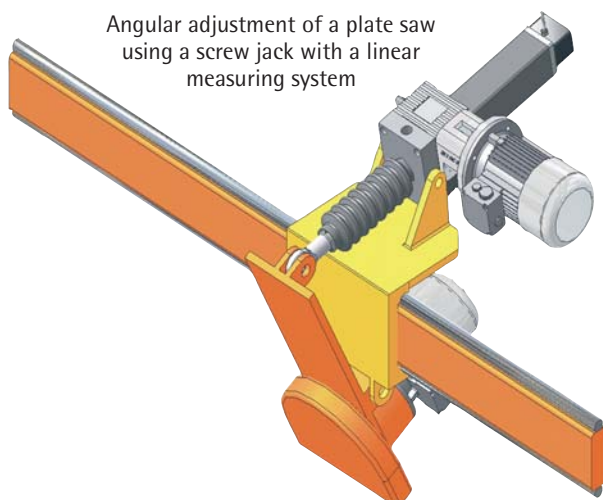
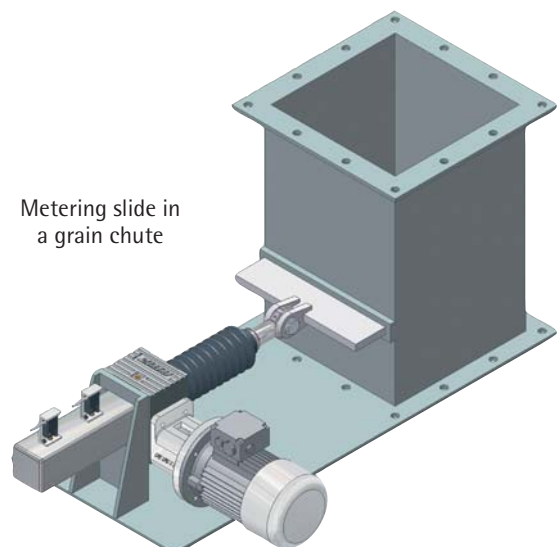
Angular adjustment of a plate saw  
using a screw jack with a linear  
measuring systemMetering slide in  
a grain chute



## Screw jack application examples

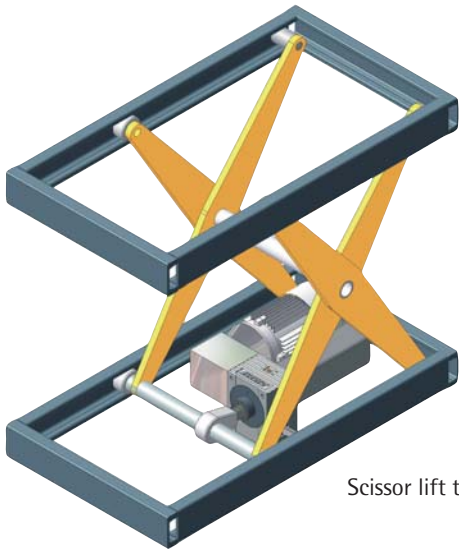

Scissor lift table

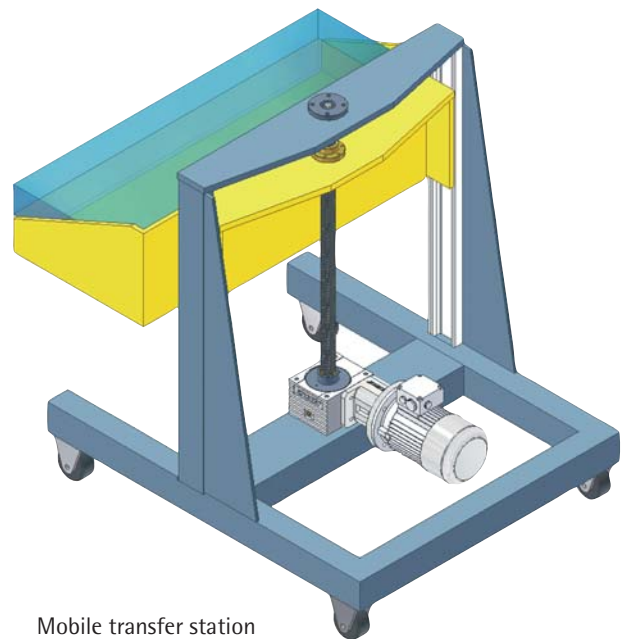

Mobile transfer station

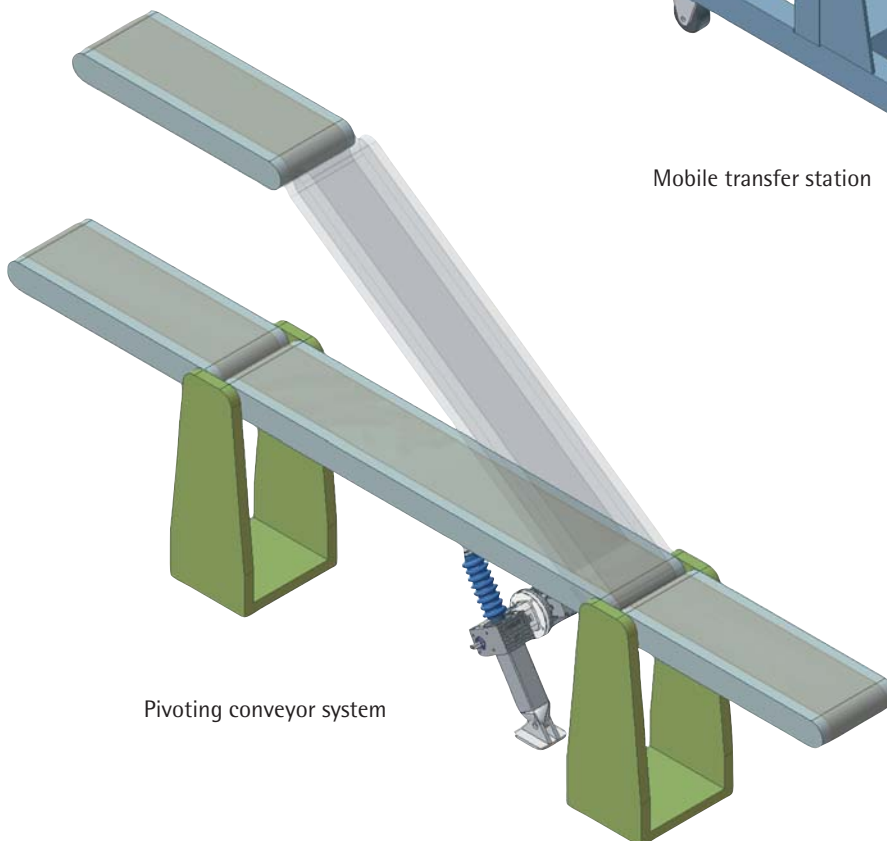

Pivoting conveyor system

## Screw jack application examples

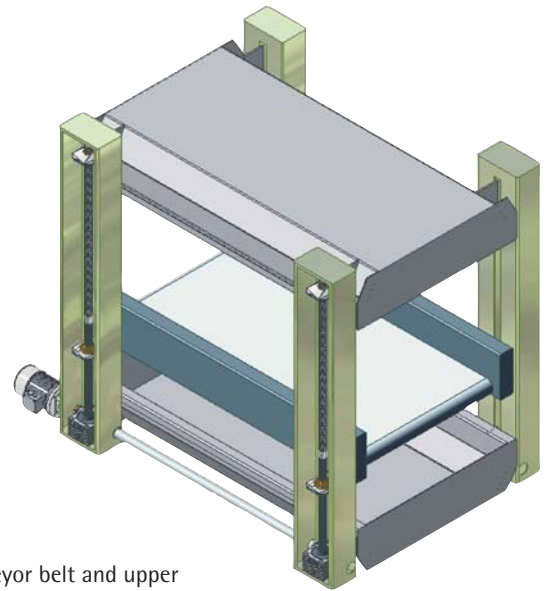
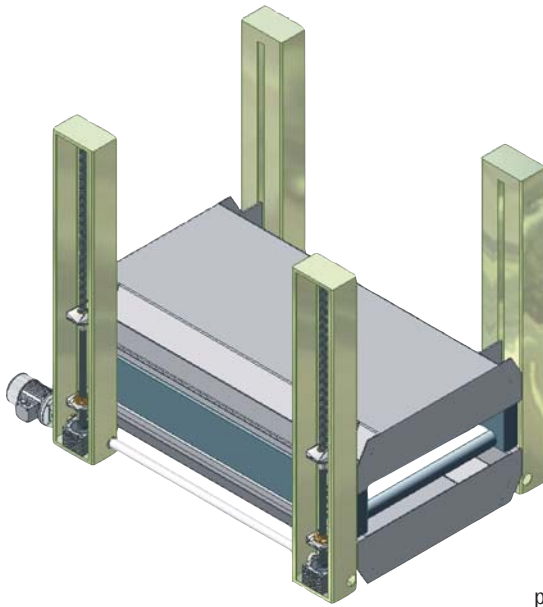

Cooling tunnel - the conveyor belt and upper part are raised to different heights using different screw pitches (single-pitch / double-pitch) for cleaning and maintenance purposes

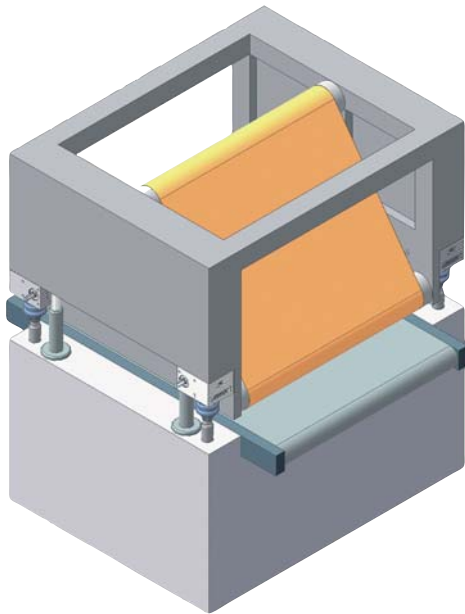

Wide belt grinding machine - precisely adjustable stop using 4 screw jacks

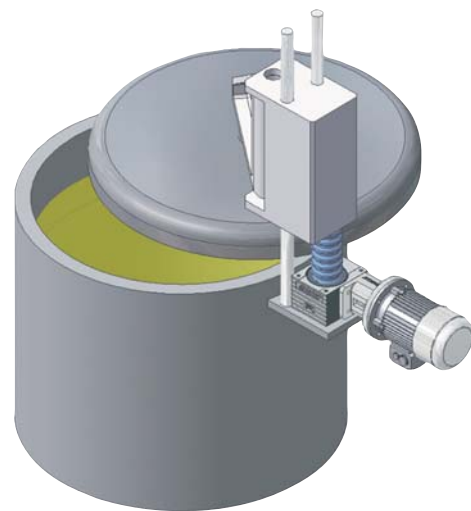

Opening and closing a container

## Screw jack application examples

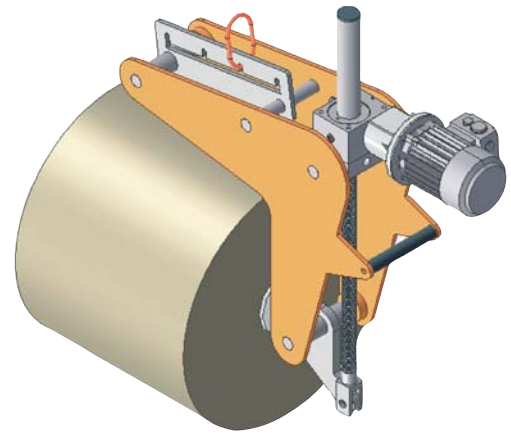
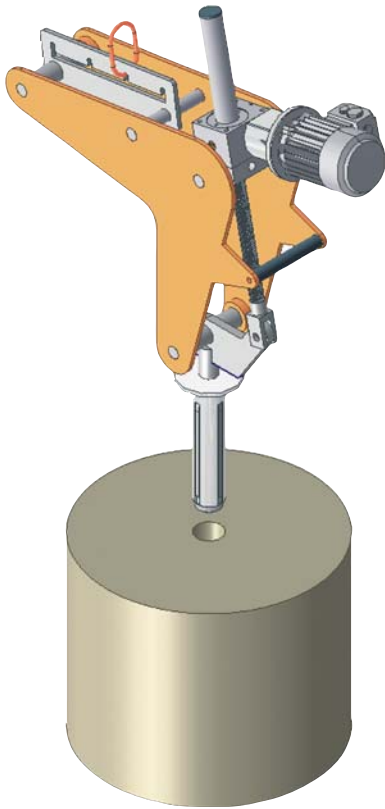

Film roll turning for horizontal and vertical loading and releasing

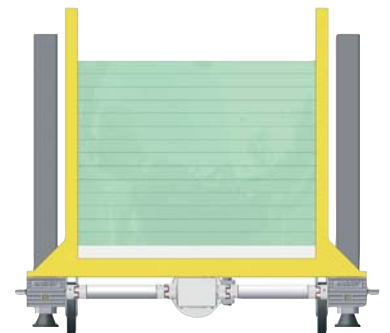
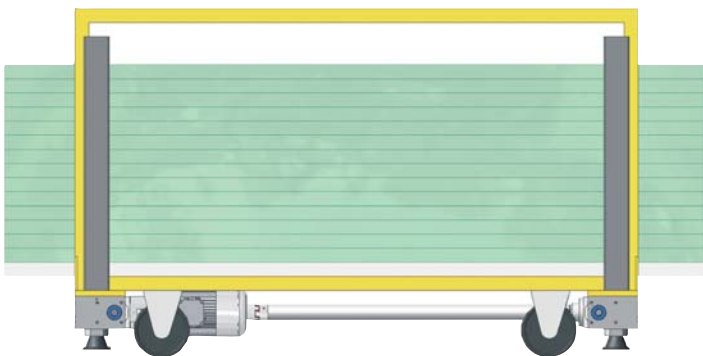

Panel transport trolley with precise height adjustment for a smooth transfer

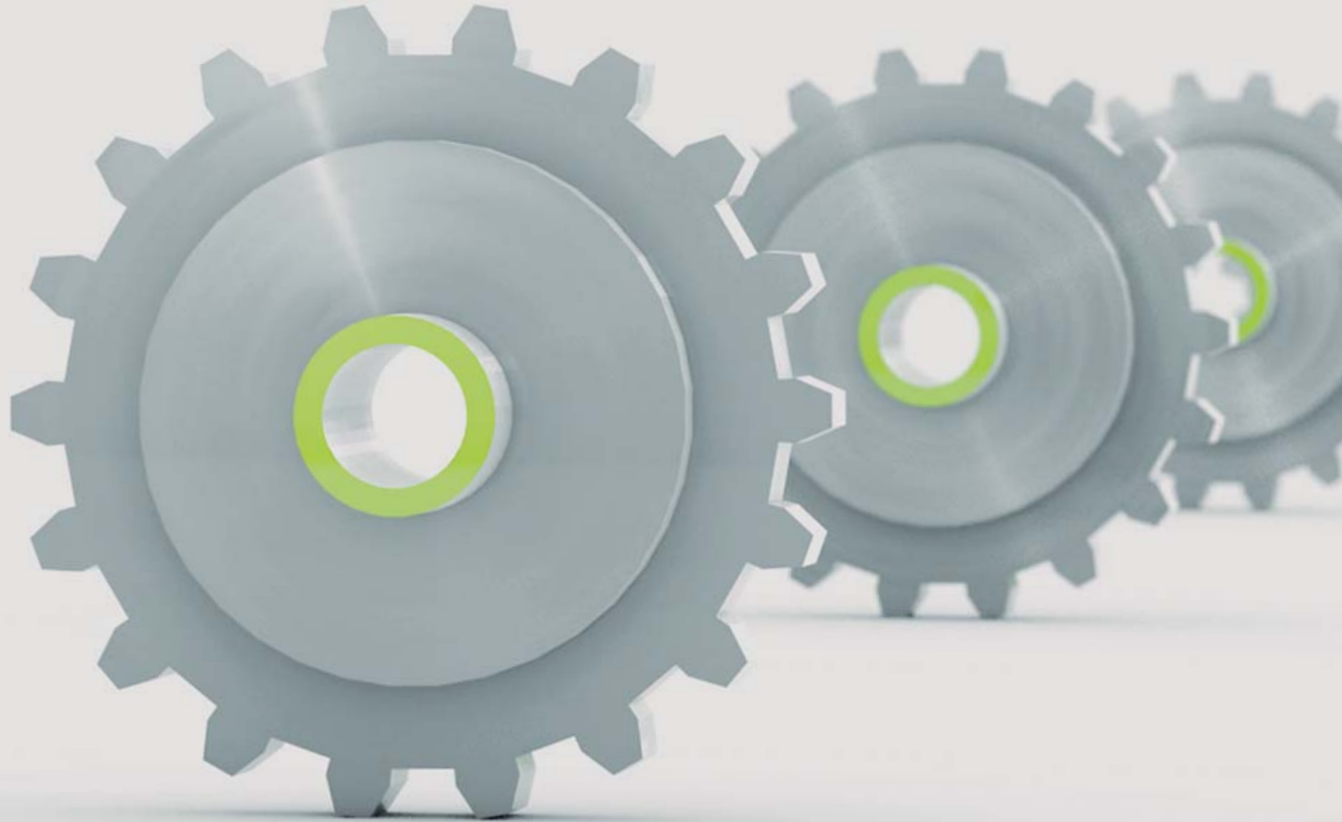

## ZIMM Transmission Parts

### Standard parts

[www.zimm-antriebstechnik.com](http://www.zimm-antriebstechnik.com)

A wide selection of standard parts from the catalogue:

- Gear technology
- Screw technology
- Fastening technology
- Linear technology

We will be happy to perform modifications to standard catalogue parts, such as drilling, slotting, turning and milling work.

Request our ZIMM Transmission Parts catalogue and let our Team advise.





Information about ZIMM Transmission Parts can be found in our Transmission Parts catalogue or by downloading from the Internet at: [www.zimm.at](http://www.zimm.at)  
(in German only available)

## ZIMM Transmission Parts Customised products

[www.zimm-antriebstechnik.com](http://www.zimm-antriebstechnik.com)

Depending on the requirements or the application, many product groups are produced to various different DIN quality classes, from one-off parts through to series production, in a variety of different materials.

On request we will undertake the logistics for you, for instance we can agree a framework order with call-off times up to approx. 12 months. The precision of our machine elements is assured by above-average inspection and testing, both during and after production.

We produce gears in a range of modules from 0.3 to 30 in sizes from 3 mm to 3,000 mm Ø, to DIN or other standards (tooth correction, straight, oblique and helical gears).

As well as gear cutting, the production of gear wheels, toothed racks, screws and threads involves broaching, turning, drilling and milling, followed by heat treatment, grinding and final inspection.

You thus receive the most economic drive element version appropriate to your application.

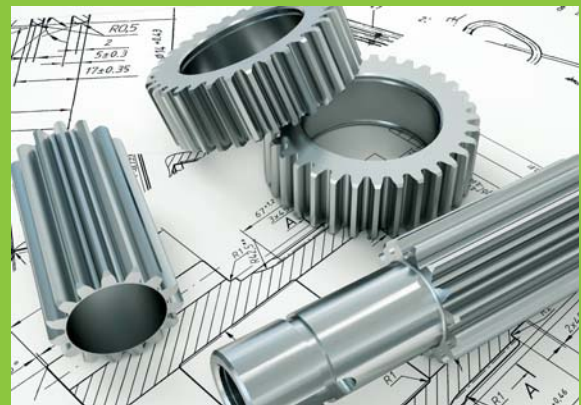



## Tradition and modernity all under one roof

We place great value on creative freedom and the courage to pursue new ideas. Our company location at Lustenau in the Vorarlberg Rhein valley reflects our entrepreneurial spirit and our philosophy "Perfection down to the last detail".

We are able to offer our customers rapid product availability thanks to our spacious warehouse and flexible production and assembly.

For us, the focus is on the customer - we take great care to provide solutions to his requirements with our innovative products and wide range of equipment.

We will be happy to apply our experience to support you.



left: Gunther Zimmermann, CEO  
right: Akan Celik MAS, Signatory



## Your partner for screw jacks and transmission parts

- 38 years experience in drive technology
- present internationally in more than 40 countries in the world
- advice and support on site from factory-based and field service staff
- innovation by constant development of our product range with new and improved models
- very high product quality and a very good price-performance ratio
- short lead times thanks to intelligent logistics and stocking levels

Well-known companies trust ZIMM. You can rely on ZIMM – your capable partner for all aspects of drive technology.

Our experienced and qualified team offer full support at all times.



left: Peter Gridling, Sales Manager (Germany and Export)  
right: Martin Gfall, Sales Manager (Austria and Switzerland)

## ©ZIMM Austria 2015

**Owner, publisher and responsible for the content:**

ZIMM Maschinenelemente GmbH + Co KG  
 Millennium Park 3, 6890 Lustenau/Austria  
 Phone: 0043 (0)5577 806-0, Fax: 0043 (0)5577 806-8  
 E-mail: info@zimm.at, www.zimm.eu

ATU 35583506, FN 15116 f, Feldkirch  
 ARA licence number 4334, DVR 0510891

**Partner with unlimited liability:**

ZIMM Maschinenelemente GmbH, Lustenau  
 CEO: Gunther Zimmermann

**Photography:**

Marcel Hagen, Helmuth Heinz, Dietmar Wanko, Lars Wieser

**Bank accounts:****Austria:**

Raiffeisenlandesbank Bregenz  
 IBAN AT40 37000 0000011999, BIC RWVGAT2B

**Germany:**

Raiffeisenlandesbank Kleinwalsertal AG  
 IBAN AT30 3743 4000 0012 3596, BIC RANJAT2B

**Switzerland:**

UBS AG  
 IBAN CH11 0029 5295 4145 8501 V, BIC UBSWCHZH80A

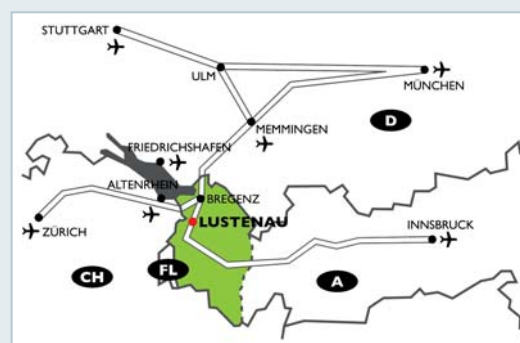
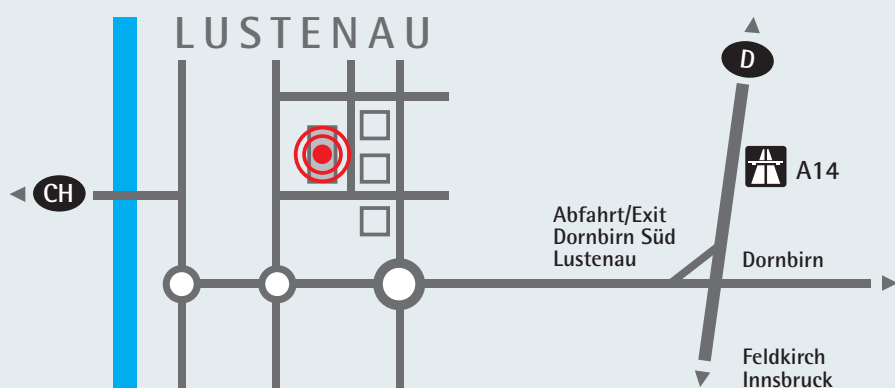
**Protection mark****for restricting the use of documents to DIN 16016.**

Except where indicated otherwise, reprinting, plagiarism, reprinting of extracts, copying of graphics and text are subject to the copyright© of ZIMM Maschinenelemente GmbH + Co KG, Millennium Park 3, 6890 Lustenau/Austria.

Storage, duplication, reproduction and distribution of the contents, in whole or in part, is permitted only with the written approval of ZIMM Maschinenelemente GmbH + Co KG, 6890 Lustenau. Breach of copyright creates liability to claims for damages. All rights are reserved in respect of granting of patents or industrial licences.

**ISO quality management certificate**

Certified according to the requirements of ISO 9001:2008  
 First certified: 17.12.1996 | Registration number: 00953/0

**Patents**

We have patents registered or pending for a range of functions and components.

**Copyright and rights of use**

All copyright and rights of use regarding information, artwork, photographs and drawings presented on our website and in our catalogues are reserved exclusively to us. Text and graphics are protected by copyright. Their use, duplication and re-use – especially where this involves distribution to third parties – requires our express permission in writing.

**Exclusion of liability**

Neither our website nor our catalogues ranks as commercial or legal advice. Such a commitment requires a specific enquiry and conclusion of a contract with us.

The contents of our catalogues and website are not binding and do not constitute an offer to conclude a contract. We accept no liability for the currency, accuracy or completeness of their contents. This applies in particular to contents of external websites accessed by links from our website. We are entitled to change the contents of our catalogues and website at any time. We accept no liability for and make no guarantee of the availability of our website or catalogues. **Drawings are valid only when they have been checked and approved by both partners in accordance with the order acknowledgement.**

**Effectiveness at law of the exclusion of liability**

If a legal relationship has arisen exclusively from the contents of our website or catalogues without any direct contact between us, this is subject exclusively to Austrian law, with exclusion of the tie-breaker rule. All legal disputes arising shall be subject to the exclusive jurisdiction of the court having competence A-6800 Feldkirch.

**Data protection declaration**

We are subject to the provisions of the Austrian Federal Data Protection Act for protection of personal data. We will pass personal information and data relating to persons to other parties only where this is for the purpose of and in relation to contractual orders. Information may be passed to suppliers and subcontractors only where such companies which can offer sufficient guarantees of secure use of the data. We are permitted to pass data to companies directly or indirectly associated with us.

ZIMM Maschinenelemente GmbH + Co KG



# General Terms and Conditions

ZIMM Maschinenelemente GmbH + Co KG  
 Millennium Park 3, 6890 Lustenau/Austria  
 Phone: 0043 (0) 55 77 806-0, Fax: 0043 (0) 55 77 806-8  
 E-mail: info@zimm.at, www.zimm.eu

## 1. General

All our contracts are subject to the following terms and conditions unless agreed to the contrary in writing: These terms and conditions are deemed acknowledged and agreed by signing the contract. Any terms and conditions – of any nature – contrary to our general terms and conditions shall be completely inapplicable and invalid, irrespective of the form in which they were brought to our knowledge. Deviations from these general terms and conditions shall be effective only if they have been agreed and confirmed by us in writing. Any agreement to abandon this formal requirement must equally be in writing and signed by both parties. Silence concerning any terms and conditions that deviate from our standard conditions shall not be regarded as consent.

## 2. Quotations | prices | contractual content

- 2.1. Our quotations remain valid for 60 days after submission, subject to changes in accordance with Point 2.5.
- 2.2. Information in our catalogues is not contractually binding (see also Point 3).
- 2.3. All our prices are understood to be in Euros and exclusive of VAT. Unless agreed to the contrary, the prices to be invoiced will be our list prices at the time of concluding the contract. These prices are ex works, excluding packaging, freight and/or shipping. Where consignment and delivery have been contractually agreed, prices do not include costs for unloading and transportation to the working site. Risk and rights of use are transferred to our contractual partner at the time of shipment. Delivery is thus always ex works.
- 2.4. **Delivery lead times and dates** are binding provided they have been promised by us in writing. This commitment lapses if our contractual partner requests modification of the order after placing the order or if obstacles outside our control occur, due for instance to force majeure or late delivery by our suppliers.
- 2.5. **Changes to economic circumstances**  
 If new circumstances arise outside our control, such as materials, taxes, wage rates, strike, war, terrorist attacks, blockades, fire, natural catastrophes or acts of God, we are entitled to amend our quotations and contracts accordingly. This applies particularly in the event that the prices of copper or aluminium rise by more than 10%. In all these cases we are entitled, even after concluding the contract, to amend our prices and due dates.

## 3. Design and specification

Selection and dimensioning is the customer's responsibility, because we are not familiar with the design criteria such as installation location and type of application. On request we can provide support during selection and specification and make proposals with subassembly drawings and calculations based on your application parameters. This drawing including the parts list is subject to checking by you and approval by us. The drawing checked and approved by you is the basis for production and assembly.

## 4. Technical modifications during the contract

We are entitled to implement technical modifications after the conclusion of the contract, provided such modifications do not affect the contractual guaranteed performance of the goods.

## 5. Warranty and liability for defects

- 5.1. The warranty period is 1 year, without exception. Changes to the warranty period require our express commitment in writing.
- 5.2. Trial runs without load and under load in normal operating conditions (according to your design parameters) are necessary to ensure reliable operation.

We perform our trials under no-load conditions, not under load, but under the customer's installation conditions.

These on-site trial runs are necessary to achieve system alignment and to eliminate any factors which may impair operation. We do not accept any liability for damage that is traceable back to the non-performance of on-site trials under load and representative working conditions. Furthermore we do not accept any liability, except where we have entered into a written assurance to the contrary, for installation of our products in any type of land vehicle, aircraft or water craft.

- 5.3. Our contractual partners are obligated to verify goods after delivery and, if necessary, inform us in writing immediately, and in any case no later than within 14 days after delivery, about any defects. If no notice of defects is communicated within this time limit, the goods that are delivered are deemed approved and warranty claims –and damage claims shall be excluded.
- 5.4. Our **liability** shall be limited to intentional and severe gross negligence. Any liability for ordinary negligence, for consequential damages, financial loss, loss of profit, loss of interest or for damages resulting from claims of third parties shall be excluded.
- 5.5. **Mechatronic products**  
 Especially for applications that are installed outdoors, the equipment is subject to environmental conditions to an increased degree. If malfunctions arise, we require documentary evidence of the cause, such as environmental influences or product defects.
- 5.6. **Rectification of defects**  
 If product defects are accepted, the defective parts must be returned to us without delay, together with documentation of the defect. Your analysis of the cause of the defect is the basis for our laboratory testing and sustained defect prevention measures. The transport costs will be borne by the sender in each case.

## 6. Retention of title

- 6.1. All goods delivered shall remain our sole property until complete payment of the purchase price.
- 6.2. Our contractual partner is obliged to treat the goods carefully as long as retention of title applies to the delivered goods. If maintenance and/or inspection work is necessary, our contractual partner shall carry out such work regularly at his own expense.
- 6.3. Installation or modification of the delivered contractual goods will not result in loss of title to those goods. Our contractual partner is not entitled to resell the delivered contractual goods as long as retention of title remains in force.

## 7. Place of performance | Applicable law | Place of jurisdiction

The exclusive place of performance for all contractual relations is A-6890 Lustenau. Austrian law applies exclusively, with exclusion of the tie-breaker rule. All legal disputes arising from or relating to the business relations and contracts shall be subject to the exclusive jurisdiction of the court having competence A-6800 Feldkirch.

## 8. Severability clause

Should any individual provisions in the above general terms and conditions be or become invalid, either in part or in full, this will not affect the validity of the other provisions. The invalid provision will be replaced by a ruling that is as close as possible in economic purpose to the invalid provision in a legally effective and practicable form.

ZIMM Maschinenelemente GmbH + Co KG

## EUROPE



AUSTRIA



BELGIUM



HUNGARY



RUSSIA



GERMANY



CZECH REPUBLIC



ITALY



SLOVENIA



SWITZERLAND



SLOVAKIA



NETHERLAND



SPAIN



LIECHTENSTEIN



DENMARK



NORWAY



SWEDEN



FINLAND



POLAND



TURKEY



FRANCE



PORTUGAL



GREAT BRITAIN



ROMANIA

inter

## ASIA



CHINA



INDIA



ISRAEL



SOUTH KOREA



TAIWAN

AUSTRALIA  
NEW ZEALAND

AUSTRALIA



NEW ZEALAND

NORTH AMERICA  
SOUTH AMERICA

USA



CANADA



BRAZIL



Your competent partner can  
be found on [www.zimm.eu](http://www.zimm.eu)

# national



**ZIMM**<sup>®</sup> Austria  
Screw Jack Systems

---

**ZIMM Maschinenelemente GmbH + Co KG**

Millennium Park 3  
6890 Lustenau/Austria  
Phone: 00 43 (0) 55 77/806-0  
Fax: 00 43 (0) 55 77/806-8  
E-mail: [info@zimm.at](mailto:info@zimm.at)  
Internet: [www.zimm.eu](http://www.zimm.eu)